

# Bambu Lab P1S-Combo 3D Printer

## Quick Start

Please review the entire guide before operating the printer.

\* Safety Notice: Do not connect to power until assembly is complete.

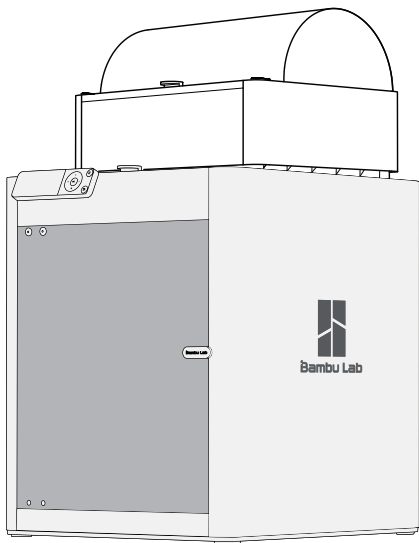



**Bambu Studio & Bambu Handy**  
<https://bambulab.com/download>

---

## \*Warning:

- When operating the AMS, we recommend using Bambu Filament, which has been thoroughly tested to work with the AMS.
- **Please make sure to avoid using soft materials like TPU or damp PVA, as they can get stuck in the AMS.**
- AMS supports spool width of 50 mm - 68 mm. We highly recommend using filament with plastic spools that fit correctly inside the AMS. If you prefer to use cardboard spools, we strongly advise using a spool adapter to reduce the risk of slippage and debris getting left behind in the AMS.
- If you run into any issues with specific filaments, please let us know so that we can provide better advice to our community.



## Component Introduction

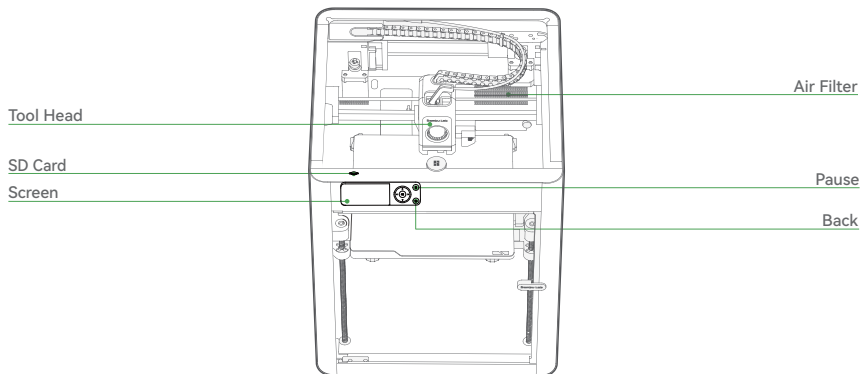

Chamber Camera



Build Plate

Auxiliary Part Cooling Fan

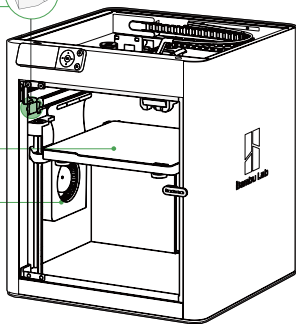

USB Charging Port

Belt Tensioner

Bambu Bus Port 4-Pin

Excess Chute

Power Socket

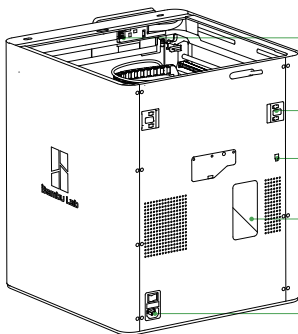

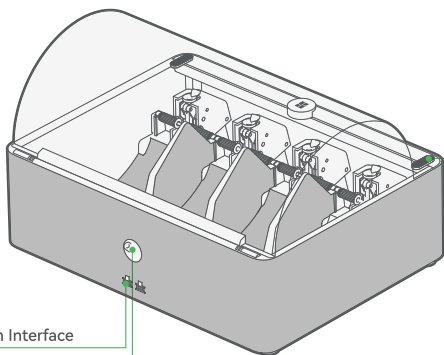

Buckle

Bambu Bus Cable 6-Pin Interface

Filament Outlet

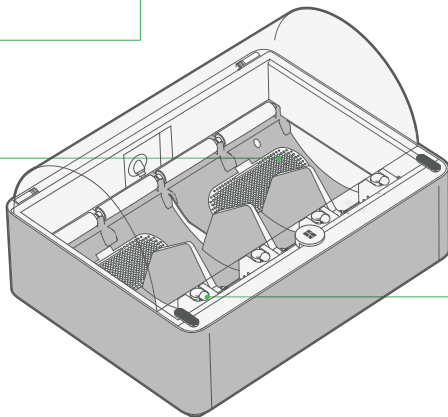

Desiccant

Filament Inlet

## Accessory Specification

---

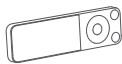

Screen



Spool Holder

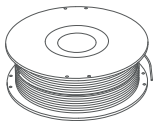

250g Filament (x3)



Spare Hot End



Nozzle Wiping Pad (x2)

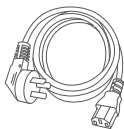

Power Cord



Spare Filament Cutter (x2)

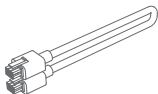

Bambu Bus Cable-6Pin



Allen Key H1.5  
Allen Key H2



Unclogging Pin Tool

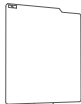

Build Plate  
( Pre-installed)

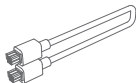

Bambu Bus Cable-4Pin



Bambu Scraper

## AMS & Tool Head Unlock

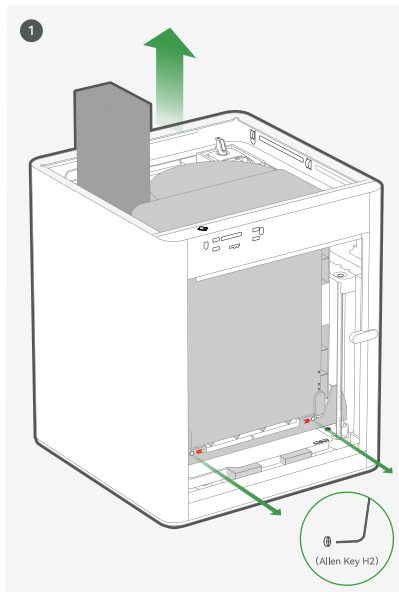

Take out the accessory box. Use Allen Key H2 to remove the screws as pictured.

\*We recommend using the short end of the Allen Key to unlock the screws more easily.

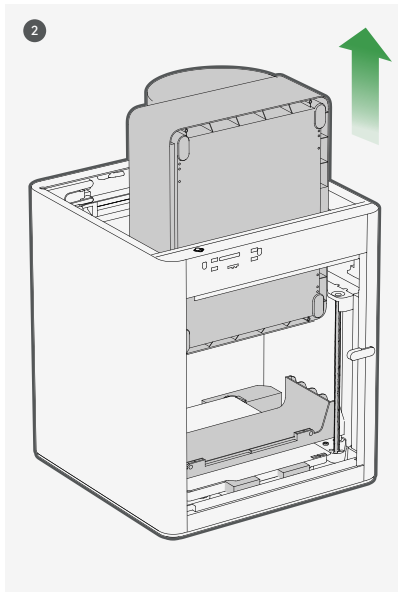

Take out the AMS by sliding it out through the top.

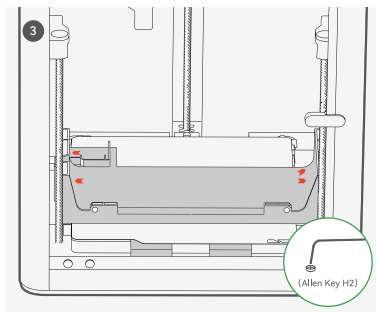

Remove the four screws as the arrows indicate.

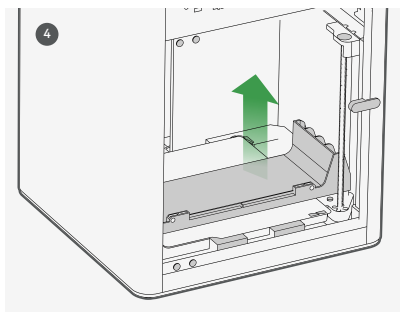

Take out the AMS cushioning.

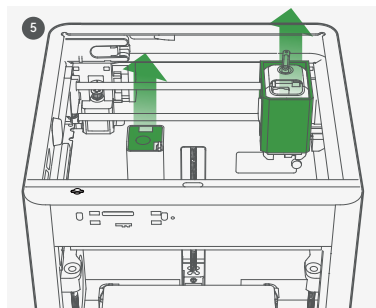

Remove the carboard from the tool head.  
Remove the foam from the excess chute.



## AMS Assembly

\*The cable-6pin can be plugged into either interface.

550mm PTFE Tube

370mm PTFE Tube

Bambu Bus Cable-6Pin

Bambu Bus Cable-4Pin

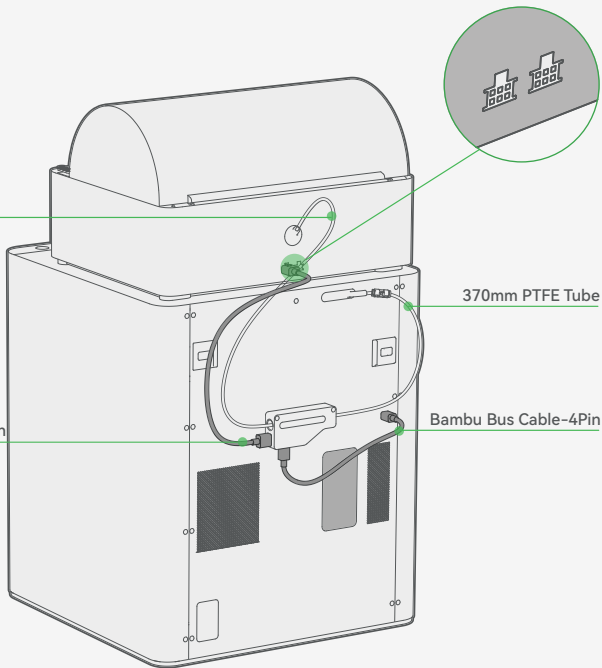

## Spool Holder Assembly

---

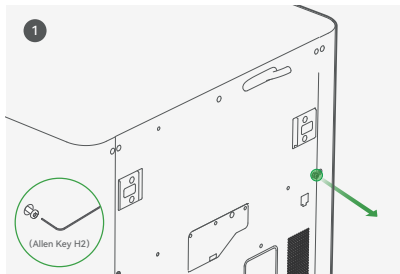

Remove the screw as pictured with an Allen Key H2.

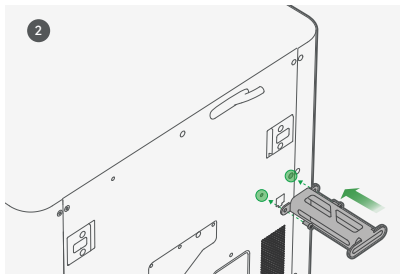

Secure the spool holder with two screws from the accessory box.

## Hot Bed Unlock & Screen Installation

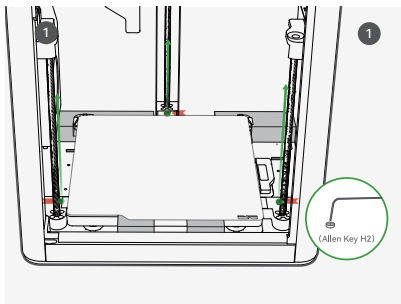

Remove the three screws with an Allen Key H2 to unlock the hot bed.

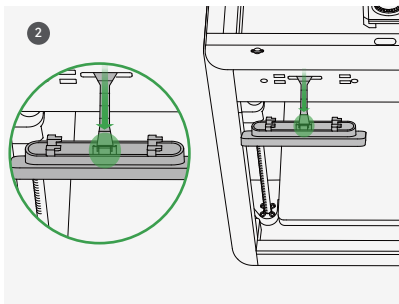

Insert the LCD cable into the port by plugging it into the terminal as pictured.

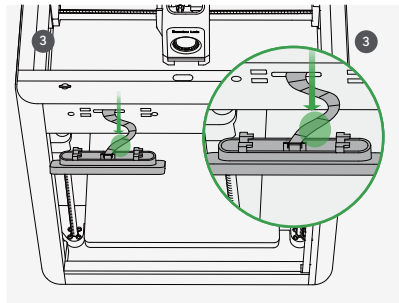

**Attention:** Bend the LCD cable towards the opening on the back of the screen as pictured.

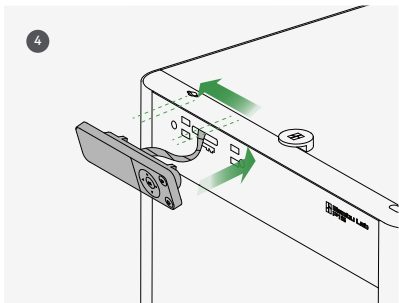

Inset the screen back to the slot on the printer, then lock it by pushing it to the left.

## Printer Binding

1. Download the Bambu Handy App. Register and log in to your Bambu Lab account.

2. Connect the printer to power. Follow the instructions on the screen until getting to the page shown on the right side.

3. Use Bambu Handy to scan the QR code on the screen, and bind your printer with your Bambu Lab account.

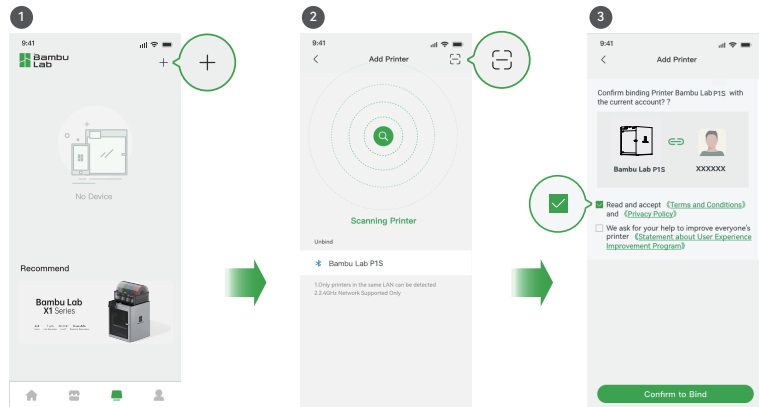

4. Follow the instructions on the screen to complete the initial calibration. It is normal to have vibration and noise during the calibration process.

**DO NOT** remove the protective foam from beneath the hot bed until after the initial calibration is complete.

## First Print

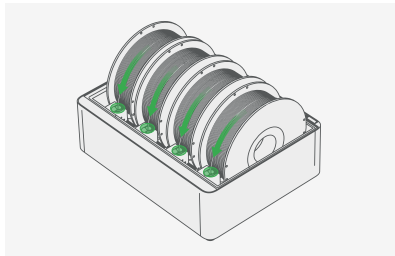
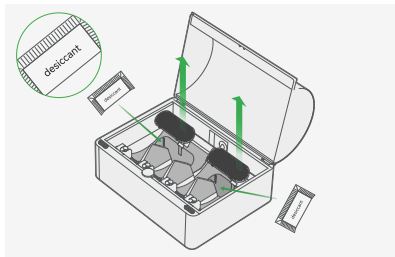

Place at least one spool of Bambu Filament into the AMS. Turn on the power to start the printer and the AMS. Insert the filament into the filament inlet. The filament will be automatically pre-loaded when detected.

\*We recommend first printing a single-color model with the supplied Bambu PLA.

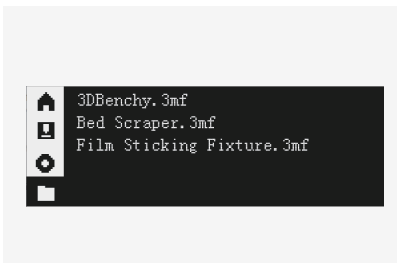

Select "■" and select a file to start the first print.

\*We recommend using one of the pre-loaded files as a first test print. All the pre-loaded files can be printed with PLA Basic or PLA Matte.

# Bambu Studio

Download Bambu Studio: <https://bambulab.com/en/download/studio>

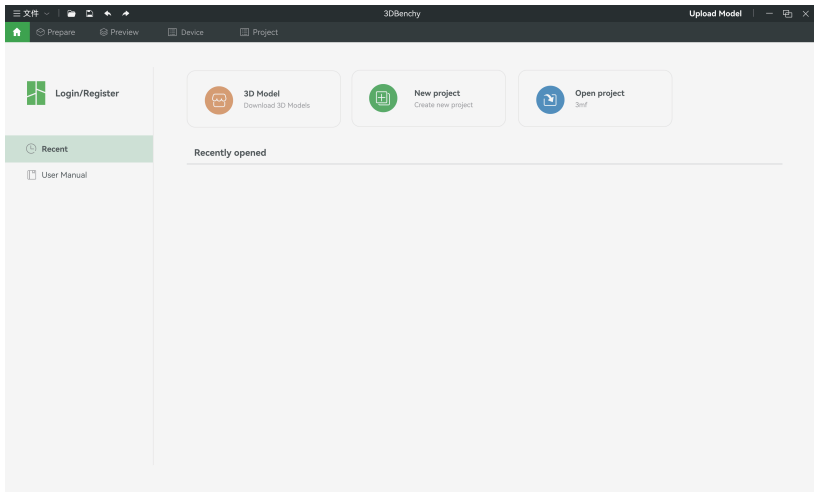

Log in to Bambu Studio with your Bambu Lab account, which is the same for the Bambu Online store. Create or open a project.

# Bambu Studio

The screenshot shows the Bambu Studio interface with the 'Send and Print' dialog box open. The dialog displays a 3D model of a green part, a printer selection dropdown set to 'Bambulab P1S', and a 'Send' button. The background shows the software's main interface with various settings panels and a 3D view of the printer bed.

**Send and Print**

37m 11.4g

PLA

Printer: Bambulab P1S

Bed Leveling

**Printer**

Bambu Lab P1S 0.4 nozzle

Bed type: PLA Plate

**Filament**

Bambu PLA Basic

**Process**  Cloud  Objects  Advance

0.20mm Standard @BBL X1C

**Quality** strength speed support others

**Layer height**

Layer height: 0.2 mm

Initial layer height: 0.2 mm

Adaptive layer height:

**Line width**

Default: 0.42 mm

First layer: 0.5 mm

Outer wall: 0.42 mm

Inner wall: 0.45 mm

Top surface: 0.42 mm

Sparse infill: 0.45 mm

Internal solid infill: 0.42 mm

Support: 0.42 mm

**Seam**

Seam position: Aligned

**Precision**

Resolution: 0.012

X-Y hole compensation: 0

X-Y contour compensation: 0

Line Type	Time	Percent	Display
Interior wall	4m	14.8%	<input checked="" type="checkbox"/>
Outer wall	8m	24.9%	<input checked="" type="checkbox"/>
Overhang wall	4m	0.2%	<input checked="" type="checkbox"/>
Overhang infill	2m	4.0%	<input checked="" type="checkbox"/>
Internal solid infill	10m	10.0%	<input checked="" type="checkbox"/>
Top surface	3m	8.4%	<input checked="" type="checkbox"/>
Bottom surface	24m	1.2%	<input checked="" type="checkbox"/>
Top edge	1m	3.6%	<input checked="" type="checkbox"/>
Top infill	5m	12.2%	<input checked="" type="checkbox"/>
Bottom	2m	19.1%	<input checked="" type="checkbox"/>
Wall			<input checked="" type="checkbox"/>
Support			<input checked="" type="checkbox"/>
Seam			<input checked="" type="checkbox"/>
Estimation			
Print time	3.76 m	11.40 g	
File size	0.29		
Print time	7m		
Printing time	30m		
Time	23m		

240 48.00

01

1 0.20

100

Slice the model, select your printer and send the model to print.

# Bambu Studio

The screenshot displays the Bambu Studio interface for a Bambu Lab P1S printer. The top navigation bar includes 'File', 'Preview', 'Device', and 'Project'. The left sidebar shows 'Bambulab P1S' with a 'Status' menu. The main 'Monitor' area features the Bambu Lab logo. Below the monitor, the 'Print progress' section shows a 3D model of a green part, a progress bar at 45%, and a time remaining of -17m. The 'Control' panel on the right includes temperature readouts (210/210°C for the nozzle, 50/50°C for the bed), a 100% lamp indicator, a circular movement dial, and buttons for 'Pause' and 'Stop'.

During printing, you can remotely monitor your print, or pause/stop printing on the "Device" interface.



## Specification

Item		Specification
Printing Technology		Fused Deposition Modeling
Body	Build Volume(W*D*H)	256*256*256 mm <sup>3</sup>
	Chassis	Steel
	Shell	Plastic & Glass
Toolhead	Hot End	All-Metal
	Extruder Gears	Steel
	Nozzle	Stainless Steel
	Max Hot End Temperature	300°C
	Nozzle Diameter (Included)	0.4 mm
	Nozzle Diameter (Optional)	0.2 mm, 0.6 mm, 0.8 mm
	Filament Cutter	Yes
	Filament Diameter	1.75 mm
Heatbed	Compatible Build Plate	Bambu Textured PEI Plate Bambu Cool Plate Bambu Engineering Plate Bambu High Temperature Plate
	Max Build Plate Temperature	100 °C
Speed	Max Speed of Toolhead	500 mm/s
	Max Acceleration of Toolhead	20 m/s <sup>2</sup>
	Max Hot End Flow	32 mm <sup>3</sup> /s @ABS(Model: 150*150mm single wall, Material: Bambu ABS, Temperature: 280°C)
Cooling	Part Cooling Fan	Closed Loop Control
	Hot End Fan	Closed Loop Control
	Control Board Fan	Closed Loop Control
	Chamber Temperature Regulator Fan	Closed Loop Control
	Auxiliary Part Cooling Fan	Closed Loop Control
	Air Filter	Activated Carbon Filter
Supported Filament	PLA, PETG, TPU, ABS, ASA, PVA, PET	Ideal
	PA, PC	Capable
	Carbon/Glass Fiber Reinforced Polymer	Not Recommended
Sensors	Chamber Monitoring Camera	Low Rate Camera 1280 x 720 / 0.5fps, Timelapse Supported
	Filament Run Out Sensor	Yes
	Filament Odometry	Optional with AMS
	Power Loss Recover	Yes

## Specification

Physical Dimensions	Dimensions(W×D×H)	389*389*458mm <sup>3</sup>
	Net Weight	12.95kg
Electrical Requirements	Input Voltage	100-240 VAC, 50/60 Hz
	Max Power	1000W@220V, 350W@110V
	USB Output Power	5V/1.5A
Electronics	Display	2.7-inch 192x64 Screen
	Connectivity	Wi-Fi, Bluetooth, Bambu-Bus
	Storage	Micro SD Card
	Control Interface	Button, APP, PC Application
	Motion Controller	Dual-Core Cortex M4
Software	Slicer	Bambu Studio Support third party slicers which export standard G-code such as Superslicer, Prusaslicer and Cura, but certain advanced features may not be supported.
	Slicer Supported OS	MacOS, Windows
Wifi	Frequency Range	2412MHz-2472MHz(CE) 2412MHz-2462MHz(FCC) 2400MHz-2483.5MHz(SRRC)
	Transmitter Power (EIRP)	≤21.5dBm(FCC) ≤20dBm(CE/SRRC)
	Protocol	IEEE802.11 b/g/n
Bluetooth	Frequency Band	2402MHz-2480MHz(CE/FCC) 2400MHz-2483.5MHz(SRRC)
	Transmitter Power (EIRP)	≤20dBm(FCC/SRRC) <10dBm(CE)
	Protocol	BLE5.0



**Bambu Studio**  
**Bambu Handy**

<https://bambulab.com/download>

## Customer Support

Please visit the Bambu Lab Wiki for more setup and maintenance tutorials.

<https://wiki.bambulab.com/en/home>



If you need support, please try either of the two approaches:

**Approach 1:** Create a support ticket on the Official Website



**Approach 2:** Create a support ticket on the Bambu Handy App

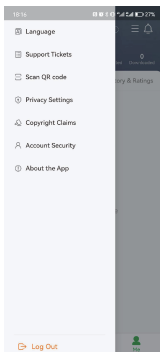
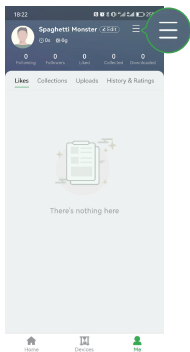



**Bambu Lab**

**Enjoy!**

[www.bambulab.com](http://www.bambulab.com)

# Bambu Lab P1S-Combo 3D Printer

## Quick Start

Please review the entire guide before operating the printer.

• Safety Notice: Do not connect to power until assembly is complete.

