

THULE Pacific 500

6315/631500

5 års garanti
years warranty
Jahre Garantie
ans de garantie

Technical approval:

TÜV/GS DIN 75302 (Germany).

Materials:

Special UV-protected and impact resistant box material.

Colour:

Lid - Grey

Bottom - Anthracite

Method of manufacture:

Vacuum forming.

Assembly:

Fast-Grip 90mm mounting system. Sliding in front and rear.
540-960 mm bar distance.

Dimensions/Weight:

Length: 2260 mm

Width: 550 mm

Height: 370 mm

Volume: 320 litres

Weight: 12 Kg

Load:

Maximum load: 50 kg. Observe vehicle manufacturers instructions and maximum roof load.



- Single side opening system.
- Special UV-protected and impact resistant box material.
- Dual-Force lid opener.
- TÜV/GS-approved.
- Central locking system.
- Fast-Grip 90mm mounting system. Sliding in front and rear.
- Featuring THULE's One Key System.

THULE Pacific 500

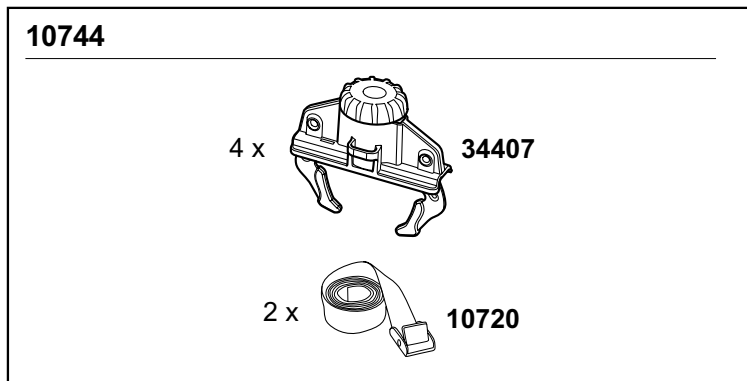
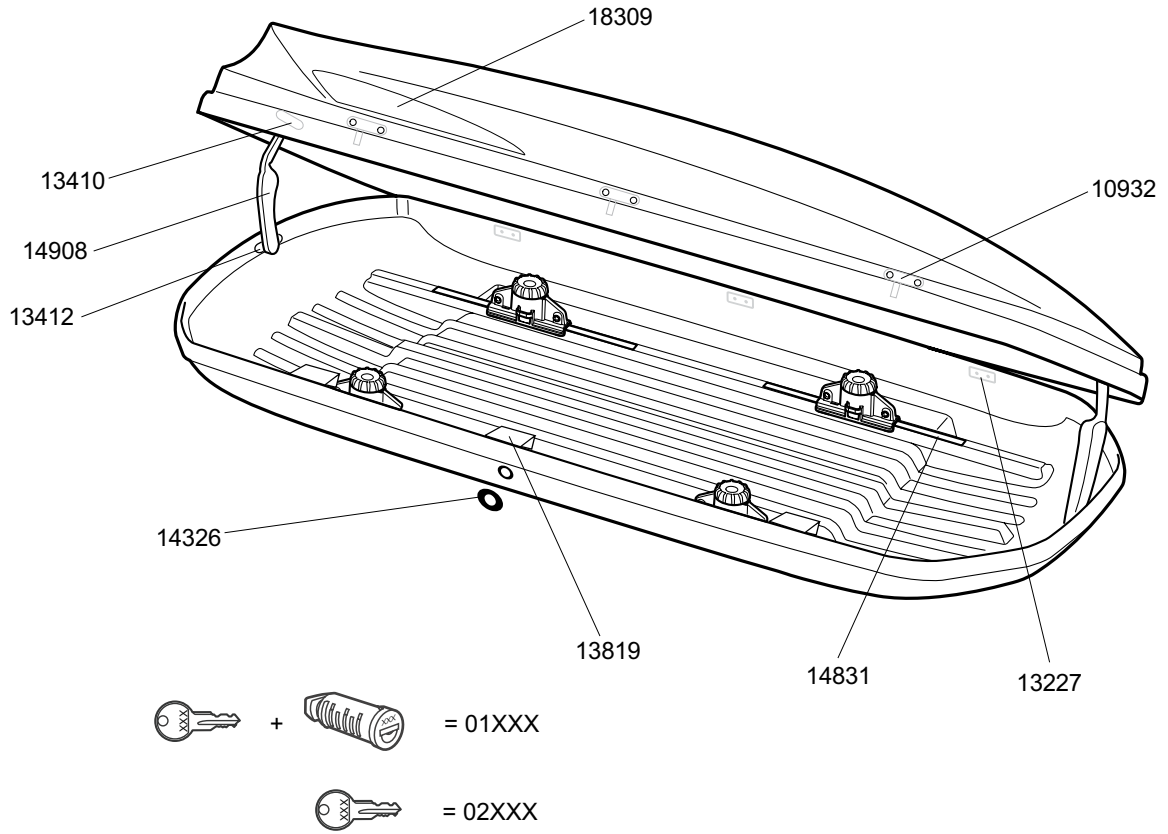

Packaging

Product	EAN	Kg	L/W/H in cm
6315	4002253000611	12	2260/550/370

Product	Boxes/Trailer
6315	125 pcs