



CREATOR™

10265



Booklet available in English on
Heft in deutscher Sprache erhältlich auf
Livret disponible en français sur
Libretto disponibile in italiano su
Folleto disponible en español en
Folheto disponível em português em
A fűzet magyarul ezen a honlapon olvasható:
Buklets latviešu valodā pieejams vietnē
如需中文版手册, 请访问

www.LEGO.com/creatorexpert



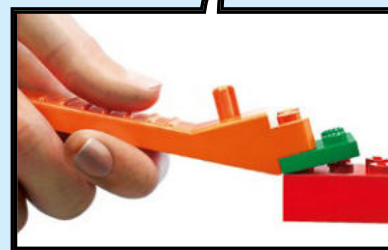
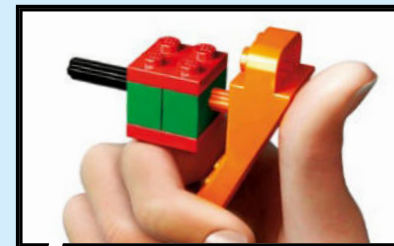
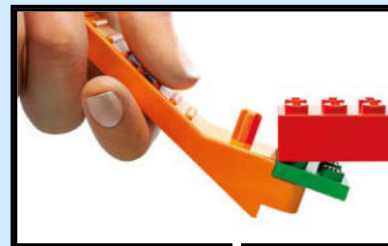
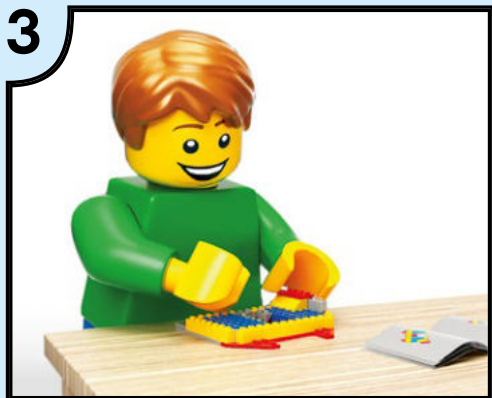
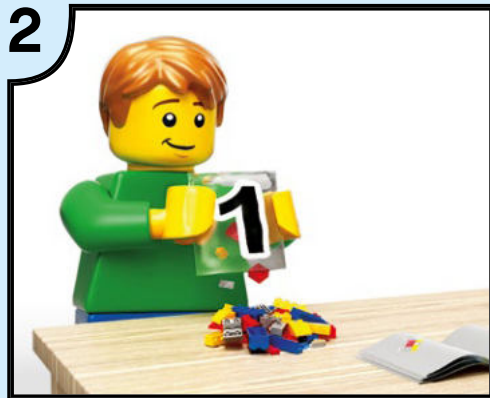

LEGO.com/brickseparator

1



2



3

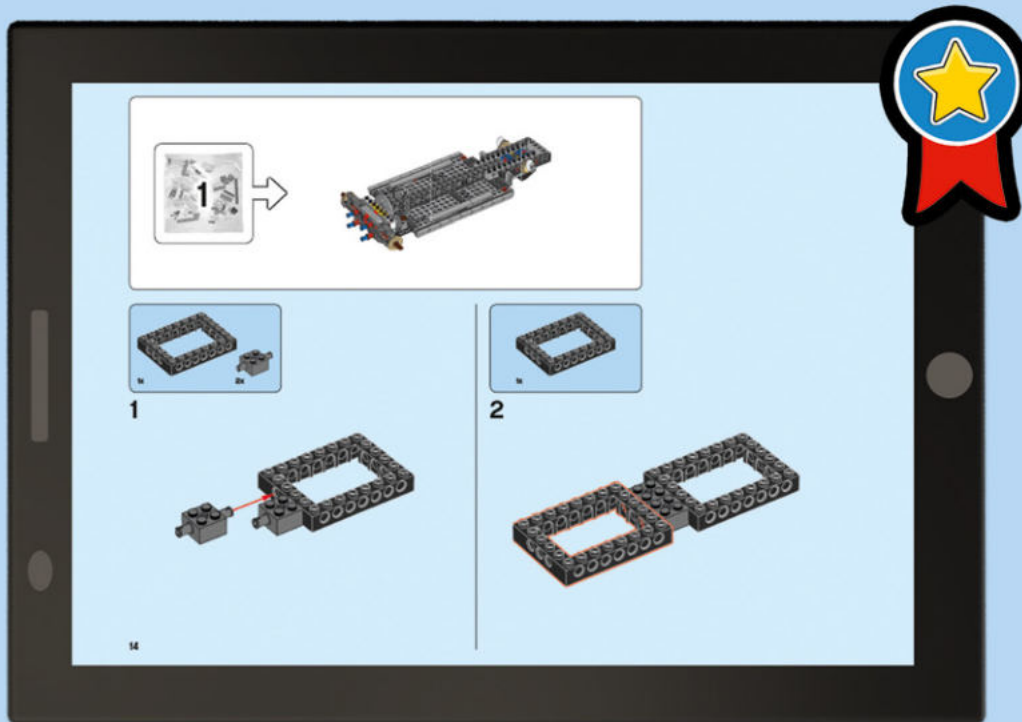

LEGO.com/apps

Check for compatibility
 Kompatibilität prüfen
 Vérifier la compatibilité
 Controlla la compatibilità
 Comprueba tu compatibilidad
 Verificar a compatibilidade
 Ellenőrizd a kompatibilitást
 Pārbaudīt saderību
 检查兼容性

“Ford Motor Company is an American icon, and Mustang is an icon for all of Ford. If there is one product that represents our company, it’s the Mustang. It’s a legend because it’s beautiful, fast and affordable. There’s nothing else out there like it – nothing combines those three attributes the way Mustang does.

I think people are so passionate about Mustang because it gives you a sense of freedom. I’ve always said if I could only own one car for the rest of my life, it would be a red Mustang convertible with a V-8 engine. It doesn’t get any better than that.”

Bill Ford Jr. Chairman, Ford Motor Company



WELCOME TO THE START OF YOUR MUSTANG STORY!

One of the most iconic cars of the last 50 years, the Ford Mustang is one of the most recognizable cars in the world. But did you know it's also one of the most customizable?

Your LEGO® model represents what's made Mustang connect with its owners and fans for so many years – a fun, stylish, sporty car that was 'Designed to Be Designed by You'. In other words, Mustang owners are not only known to mix and match

options so that it's rare to see two together exactly alike, but also to shop the aftermarket to personalize their cars.

The Mustang's ability to build a truly personal – almost emotional – connection with owners has helped make it a huge success across generations. And now it's your turn to tell the next chapter in the Mustang story.



Presenting the unexpected...
New Ford Mustang!



This is the car you never expected from Detroit. It is so distinctively beautiful it has received the Tiffany Award for Excellence in American Design, the first automobile ever to be so honored by Tiffany & Co. Mustang has the look, the fire, the flavor of one of the great European road cars. Yet it is as American as its name . . . and as practical as its price. Because Mustang is an amazingly versatile car and can be inexpensively tailored to the widest variety of individual tastes, many very different people will find it surprisingly easy to say: "This is the ideal car for me." Turn the page and you'll see why.

A TRUE CROWD-PLEASER

The Ford Mustang was the result of efforts by several key Ford people – including product planner Hal Sperlich, chief engineer Don Frey, designers Gale Halderman and Joe Oros, as well as Ford Division VP Lee Iacocca – to develop and market an exciting new automobile with widespread appeal.

Sperlich interpreted research on the record numbers of leading-edge baby-boomers and college grads entering the workforce and car market, which indicated that they were looking for a fun-to-drive second family car. Iacocca wanted to attract those young buyers to Ford with a stylish yet affordable sports car that was also practical and attainable. Frey sought to engineer



a capable but economical vehicle that was easy to manufacture, all while Halderman and Oros wanted to style something fresh and different – something sporty and, at the same time, beautiful. When they were finally able to get the green light for production from then-Ford Chairman Henry Ford II, the rest, as they say, is history.

The Ford Mustang was so successful that its name and shape soon became identifiable the world over, and even led to the creation of the term 'Pony Car' for the segment of affordable, compact cars with a sporty or high-performance image that followed.

THE BIRTH OF A LEGEND

Your LEGO® Creator Expert Ford Mustang is inspired by the classic 1967 Mustang. Featuring a long hood, short deck, optional V-8 engine and seating for four, the car made its public debut at the

New York World's Fair on April 17, 1964 and was an instant hit. Mustang's total sales from 1964-1966 were a record-breaking 1,464,362 cars!

EVOLUTION OF AN ICON

According to J Walter Thompson's Frank Thomas, Ford's advertising account executive, the Mustang name was chosen because 'it had the excitement of the wide-open spaces and was American as all hell'. The next challenge was creating an

emblem that captured that spirit. Now a true icon among car lovers the world over, here's the story of how the Mustang emblem evolved.

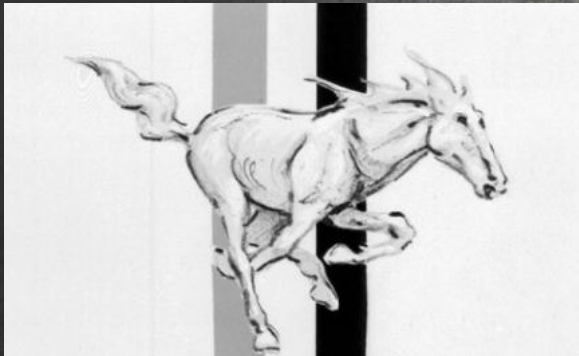

The goal was to create something that reflected both a horse for the car's name and that the car was American. Phil Clark's concept, of a galloping horse with a red, white and blue tri-bar design to reflect the Mustang's American heritage, was the initial favorite.



The proportions of the original logo were deemed too tall to fit nicely in the production-style grille corral. Design studio modelers Charles Keresztes and Waino Kangas were tasked with creating new versions of the pony for the grille and fender of the Mustang II concept and the 1965 production car.



The production grille Pony emblem surrounded by the corral on the 1965 Mustang. Compared to Phil Clark's original design, this and subsequent versions of the pony show more of a running stance rather than galloping. The head and neck are more horizontal and the tail flows out behind.

'DESIGNED TO BE DESIGNED BY YOU'

One of the secrets behind the success of the Mustang is the seemingly infinite ways it can be customized according to the owner's desires. That's why the car's first advertising slogan was: 'Designed to be designed by you'.

The Mustang's option list was a major reason for its initial success. The car could be tailored to individual buyers - you could order a basic-transportation Mustang, a sporty one, a small luxury liner or a high-performance version.

Car Life magazine summed it up at the time: "It is a sports car,

a 'gran turismo' car, an economy car, a personal car, a rally car, a sprint car, a race car, a suburban car and even a luxury car."

The car was equally popular with both young and older buyers, though more than half of first-year buyers were under 34. Notably, women bought as many Mustangs as men.



THE COLOR OF LOVE

Over the years, red has established itself as the most popular color among Mustang owners. But it wasn't always that way... brown Mustang anyone?!

In 1967, pink enthusiasts could choose either Dusty Rose or Playboy Pink.



A grand total of 19 shades of blue were available between 1967 and 1973.



Black first broke into the top three in 1994 and has remained there since.



Several special edition colors have been available over the years, including color-shifting Mystichrome on the 2004 SVT Cobra.



YELLOW and GOLD were among the favorite colors in the first generation.



Maybe a little hard to believe today but brown was one of the top three colors back in the 70s.



Roughly one in five of all Mustangs built over the past 50 years have been painted RED.



RED, BLACK and SILVER hold the top 3 color slots for nine years.

GET TO KNOW YOUR MUSTANG



LEGO® Senior Designer Mike Psiaki played a leading role in the development of the LEGO Creator Expert Ford Mustang. He runs through some of the model's most fascinating features.

Your Mustang features working front-wheel steering.



A blue 2x4 brick – the core LEGO® building block – is used at the center of the big block V8 engine, the heart of the Ford Mustang.

The doors fit seamlessly to the body when closed

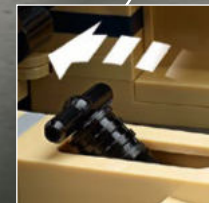

The Shift-O-Matic transmission can click between different positions, just like on the real car.

Turn the hidden wheel
to lift your Mustang!



The German number plate included with the car belonged to LEGO® Senior Designer Adam Grabowski who built one of the early concept models of the car.

TWO NEW ELEMENTS



1. 2x8 Bow brick – designed to capture the streamlined curves of the roof and air intakes.



2. 5-spoke wheel - designed to allow the steering function to fit inside the wheel for tighter turning.

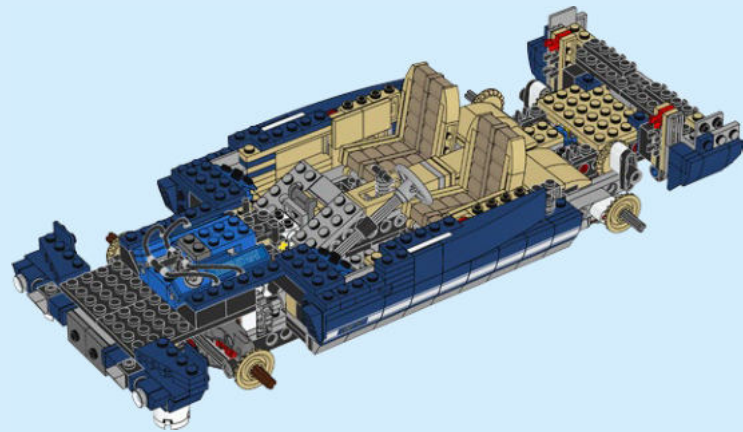
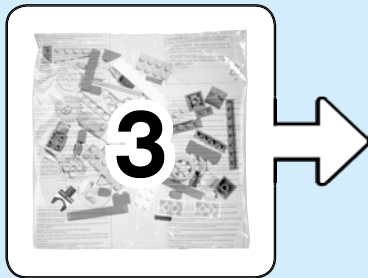
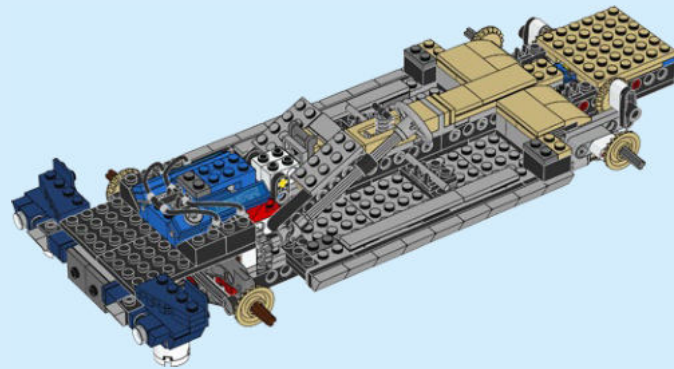
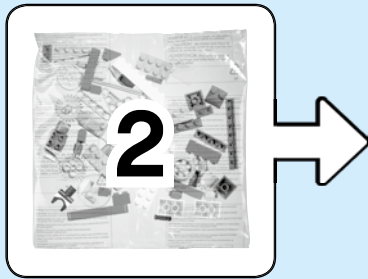
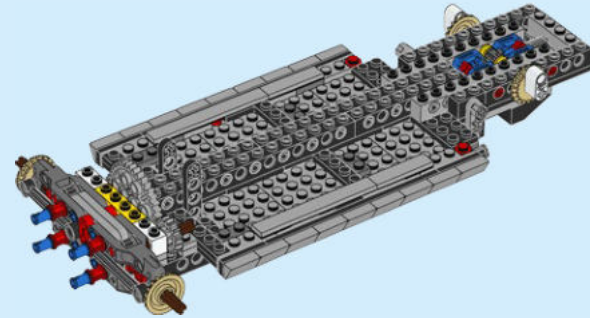
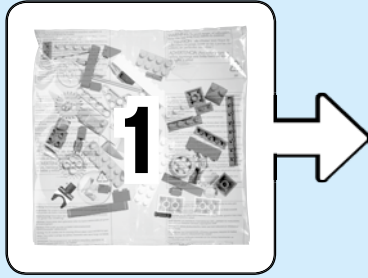

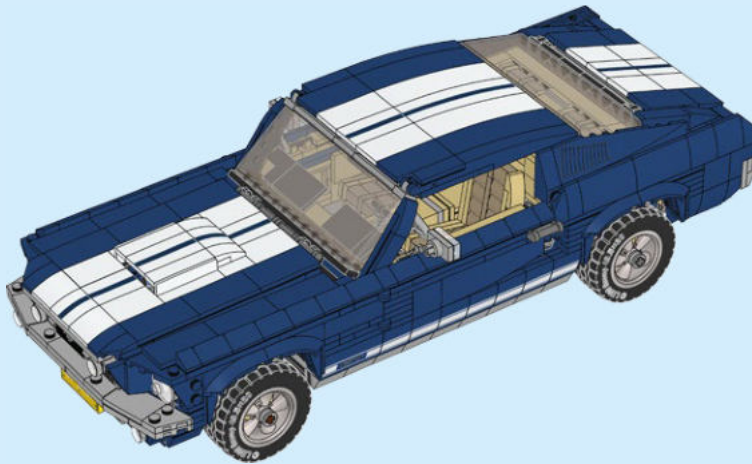
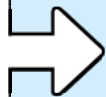
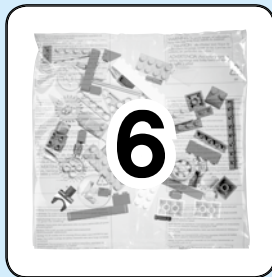
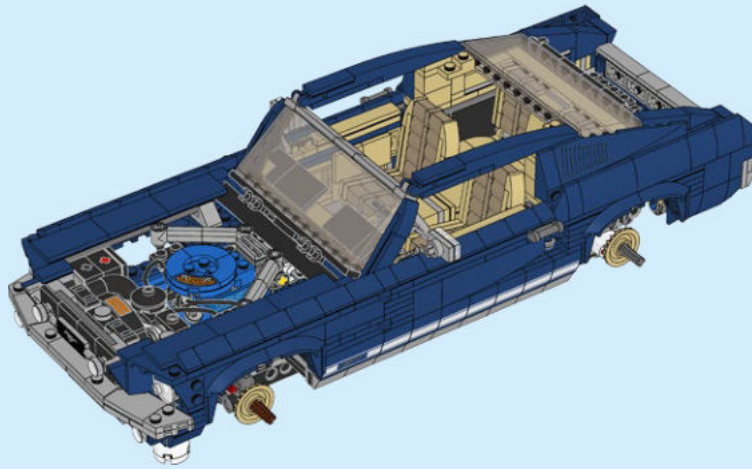
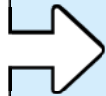
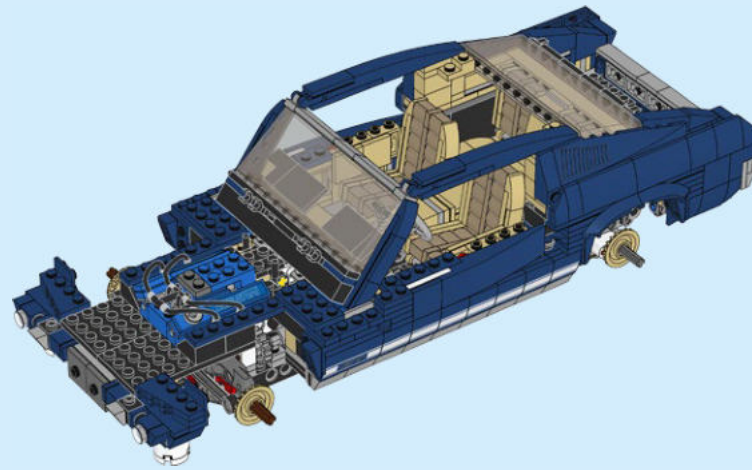
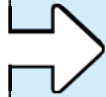
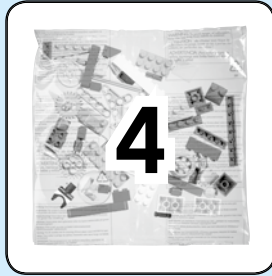

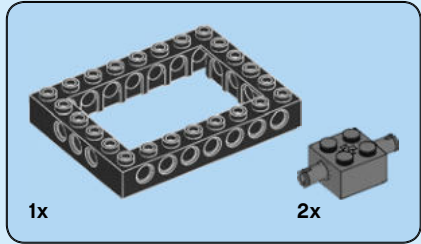
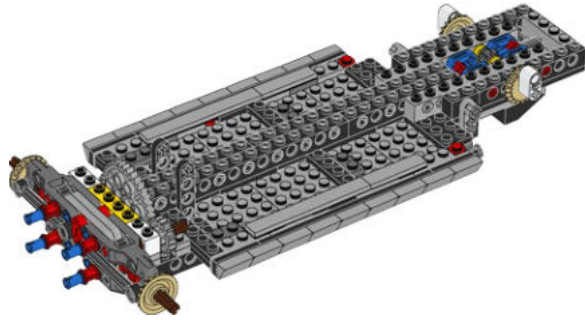

1

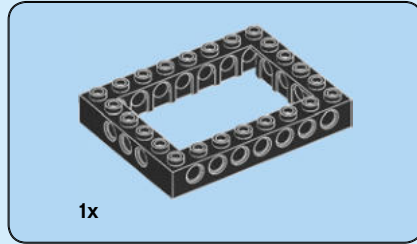
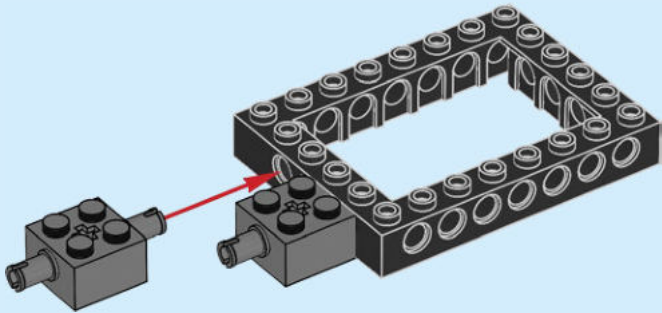

2

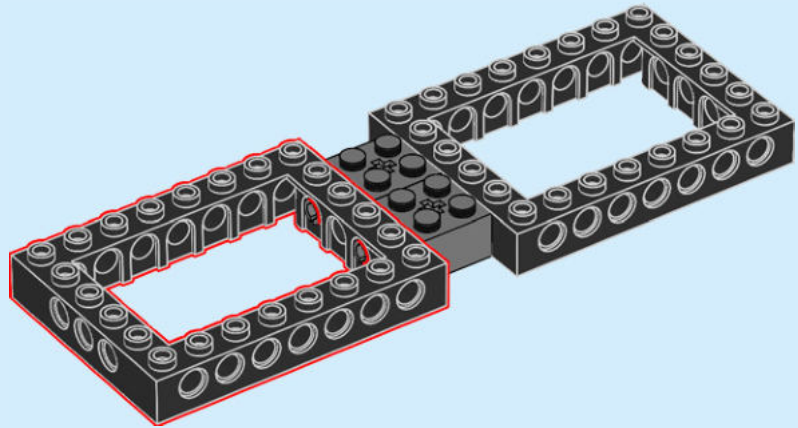

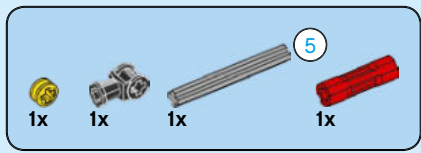

5

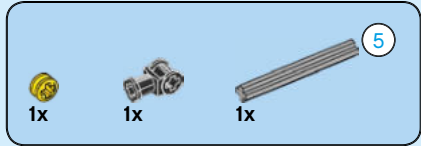
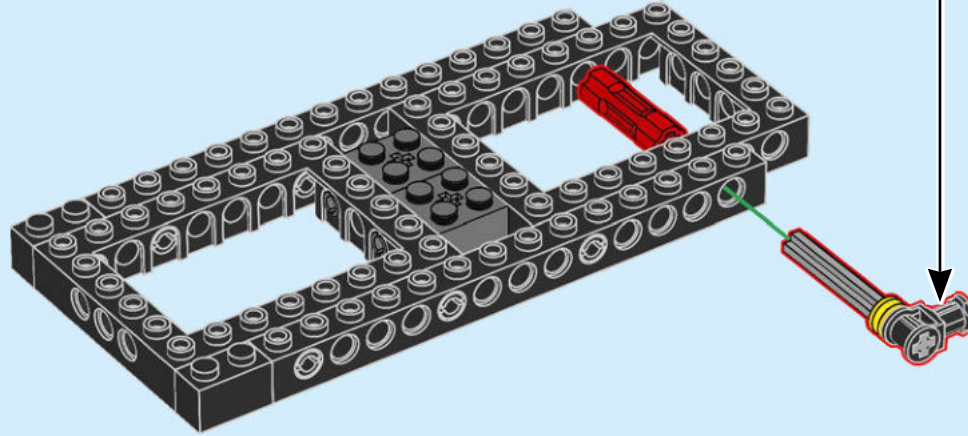
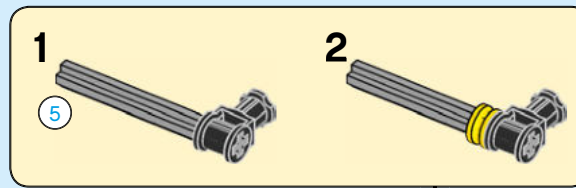
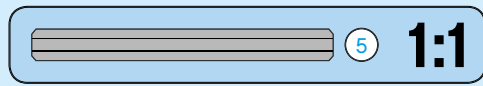

6

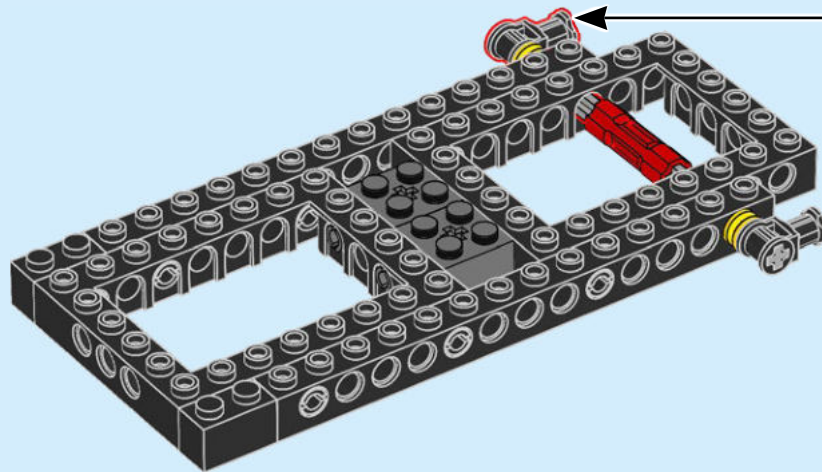
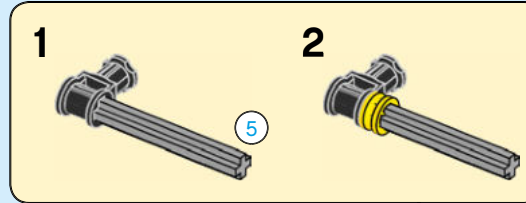

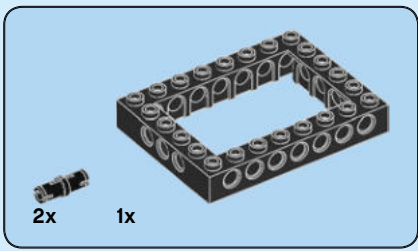

7

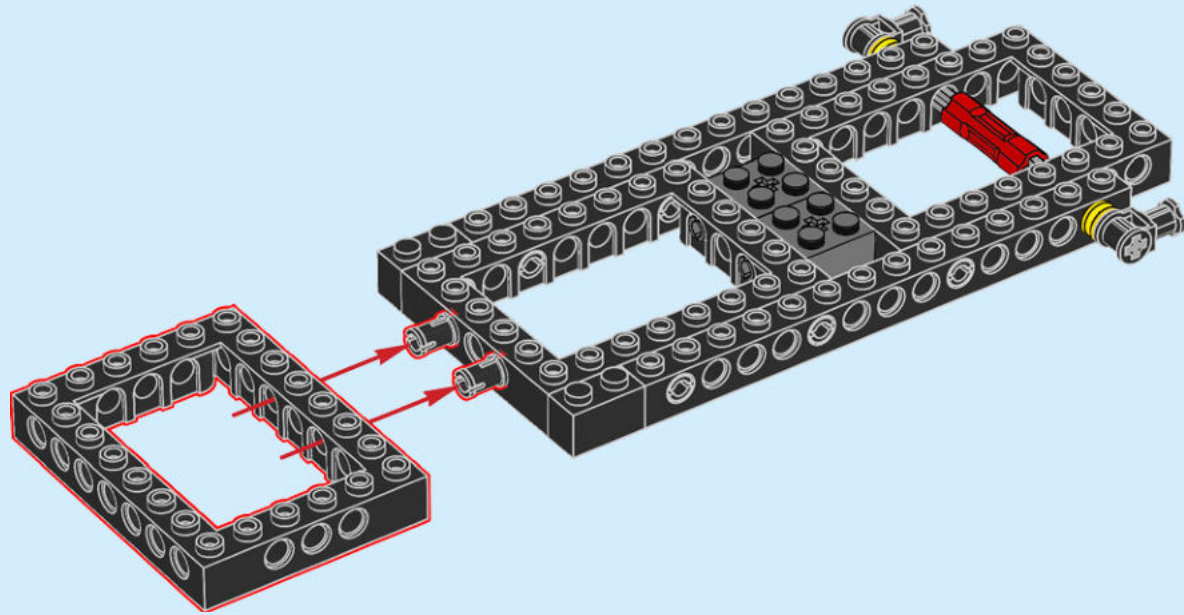

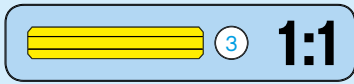
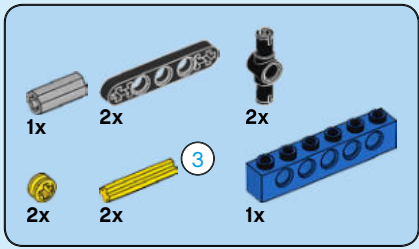

8

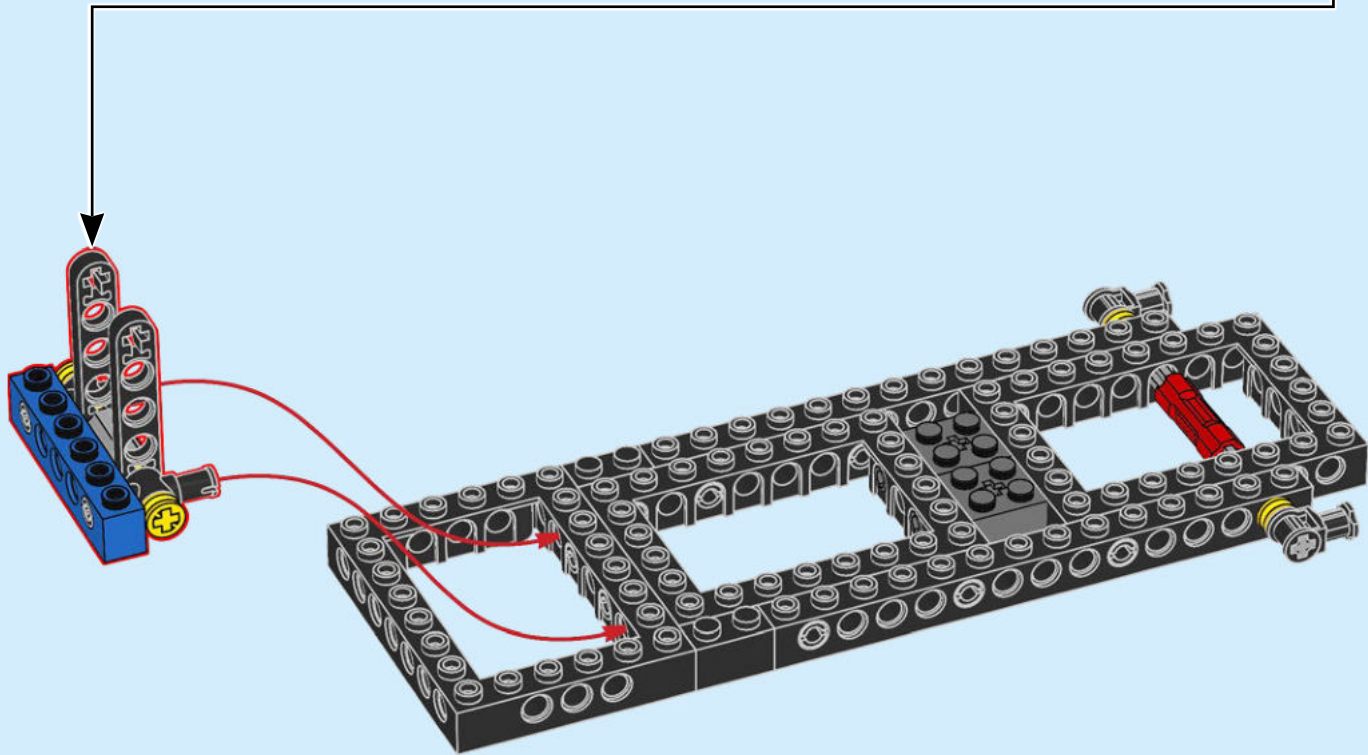
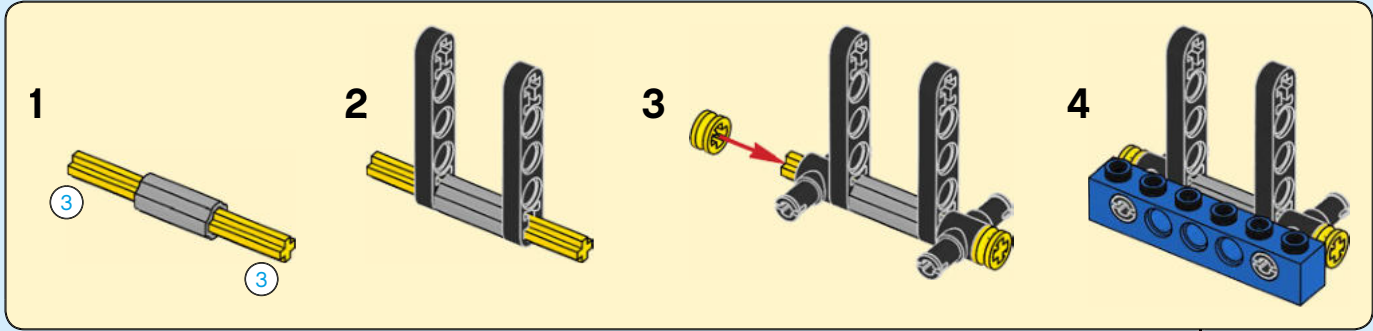

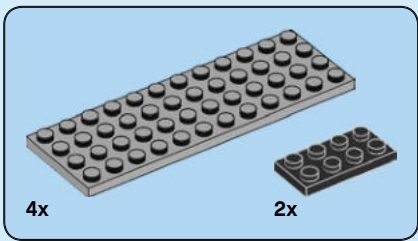

9

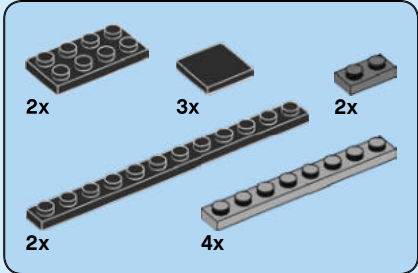
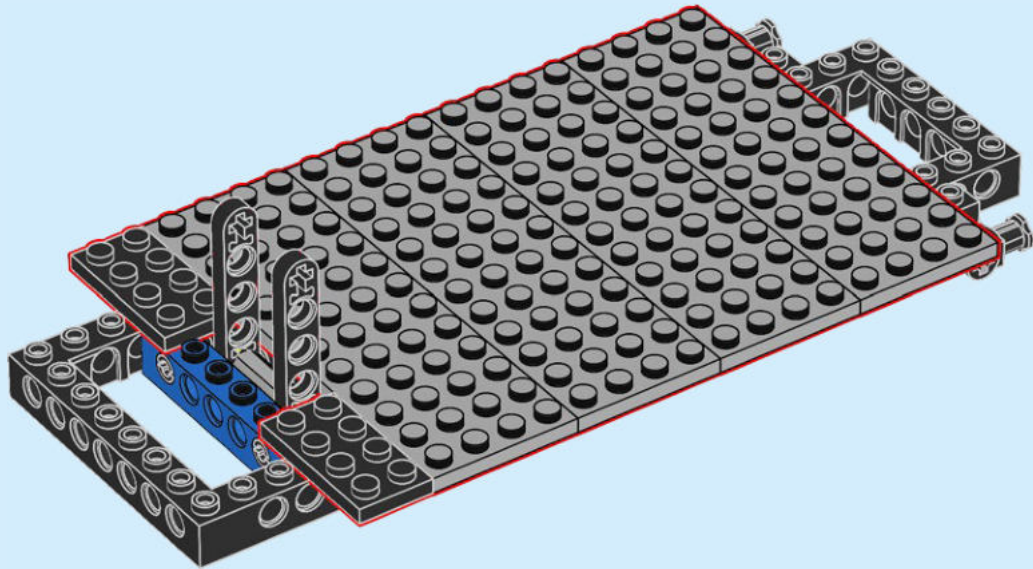

10

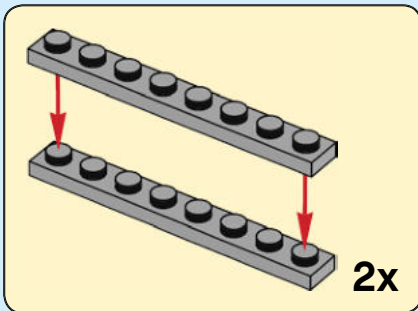
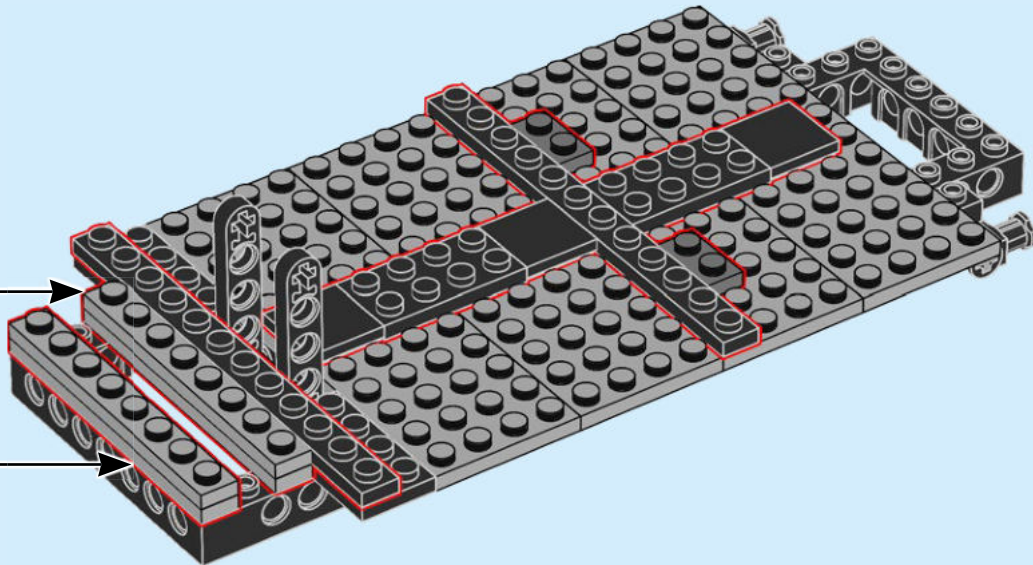

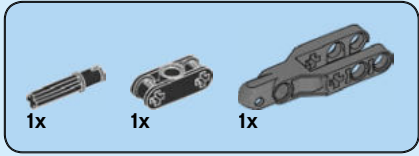
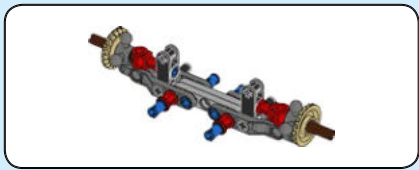

11

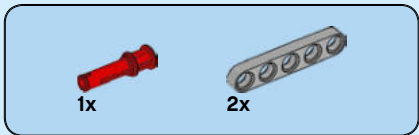
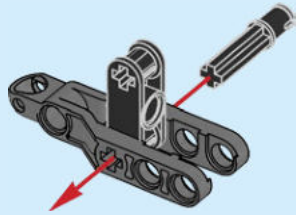

12

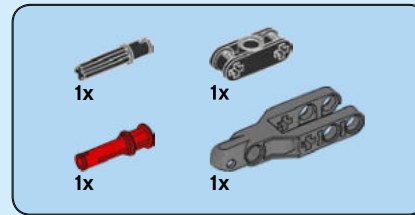
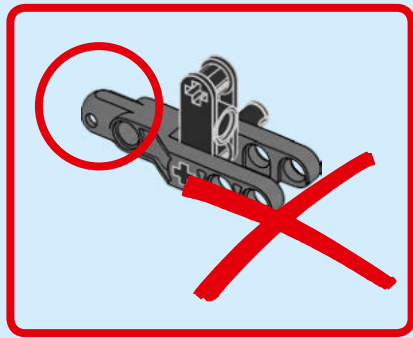
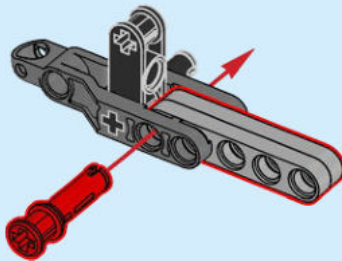

13

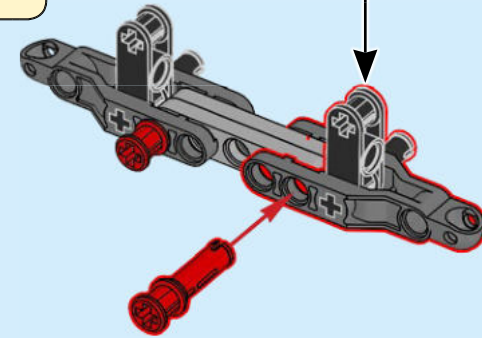
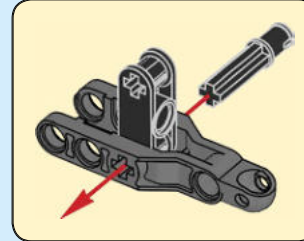

14

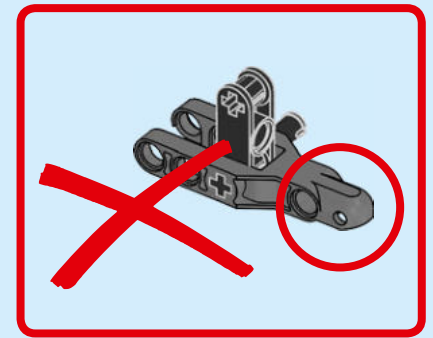
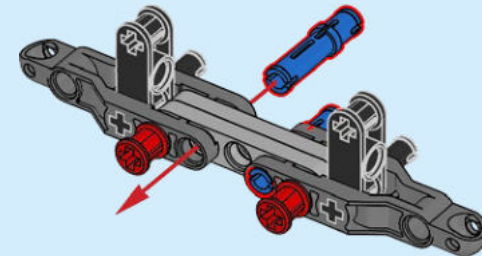



15

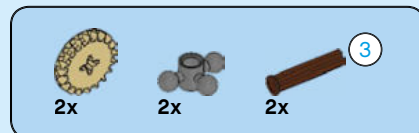
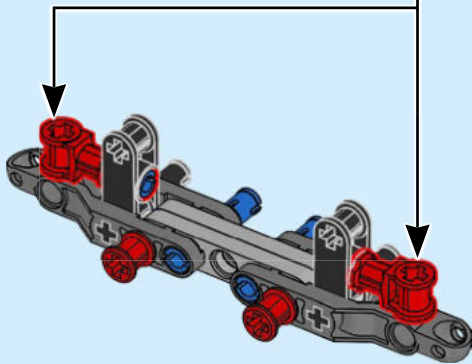
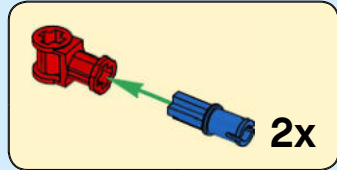

16

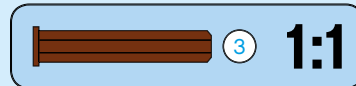
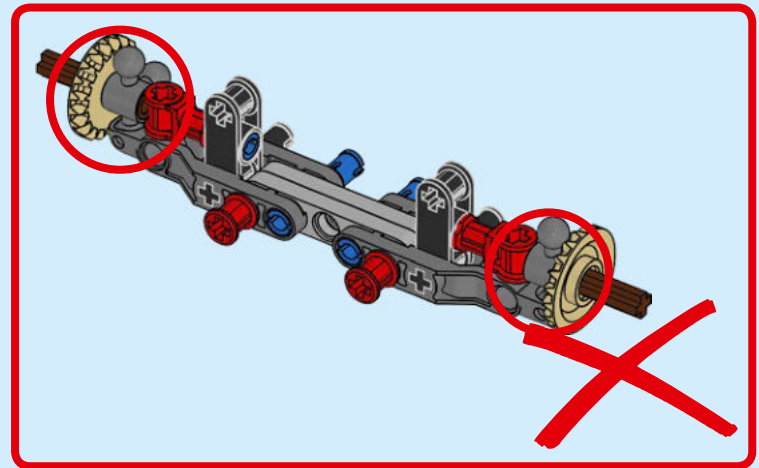
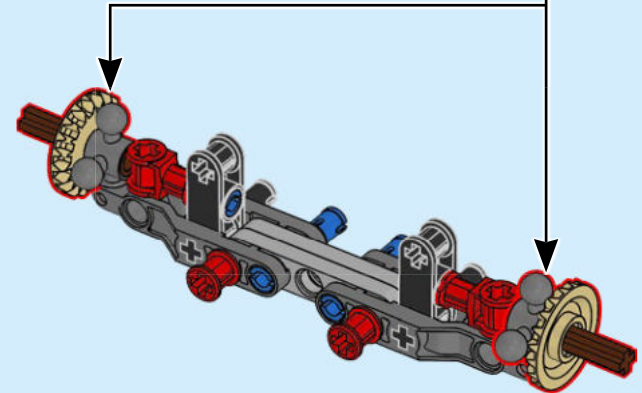
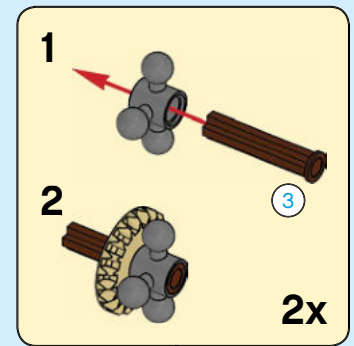



2x

17

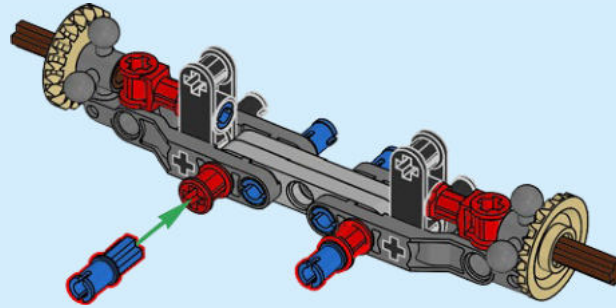

18

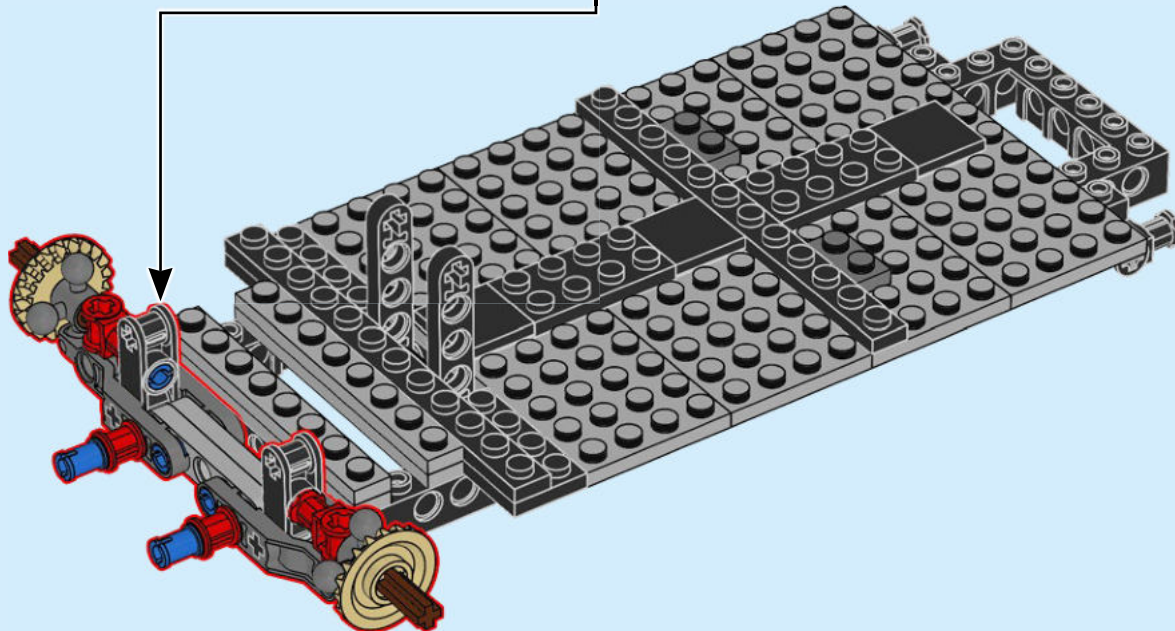

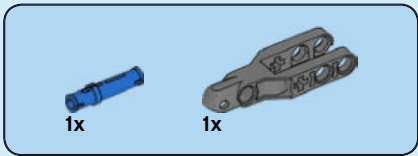
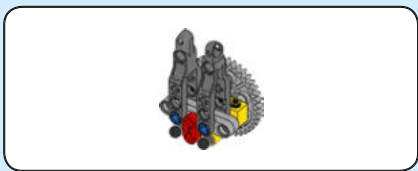

19

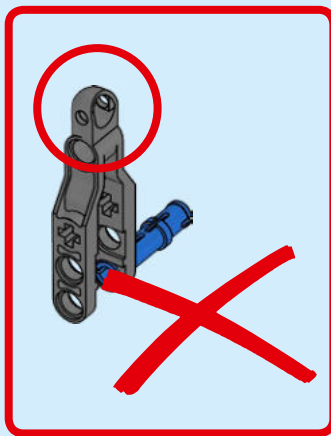

20

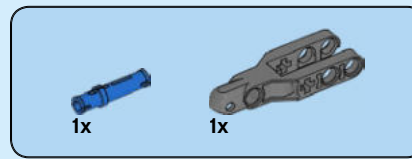
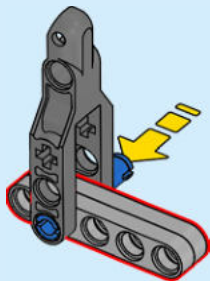

21

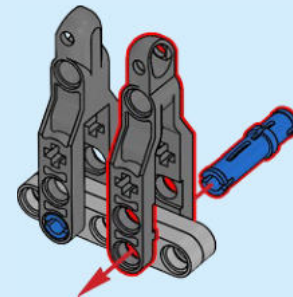
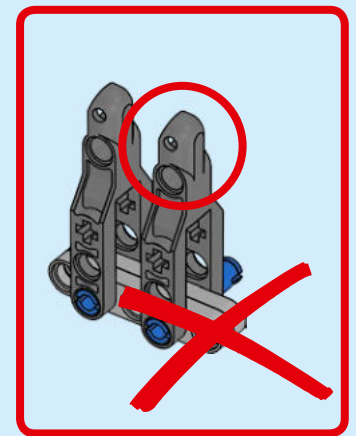

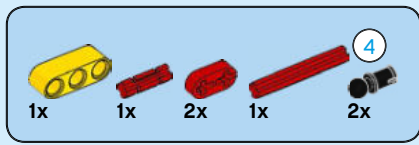

22

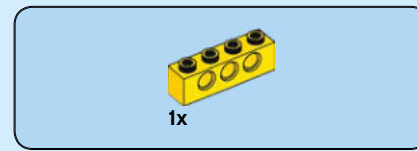
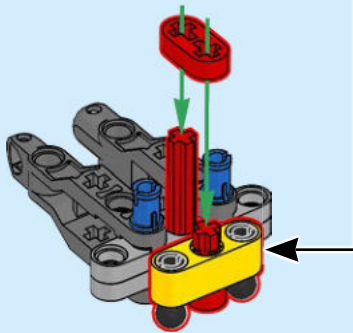
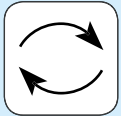
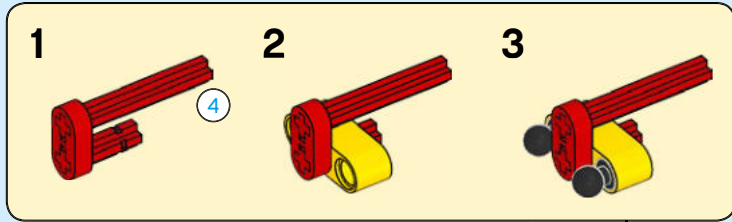
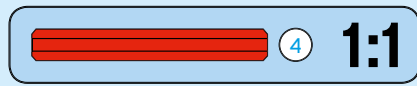

23

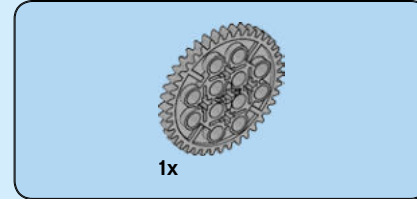
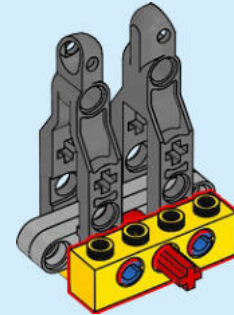
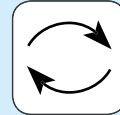

24

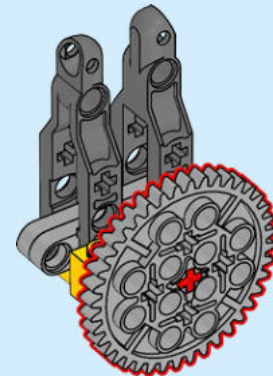

25

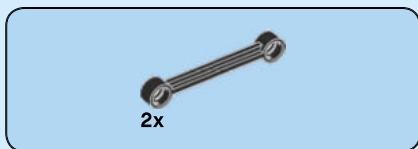
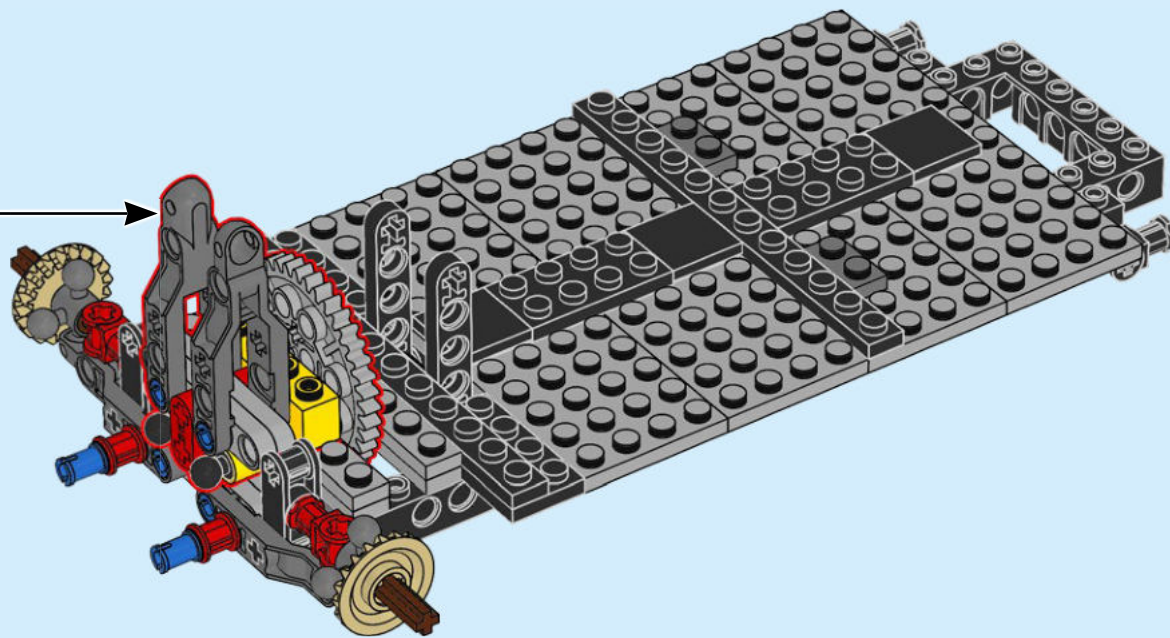

26

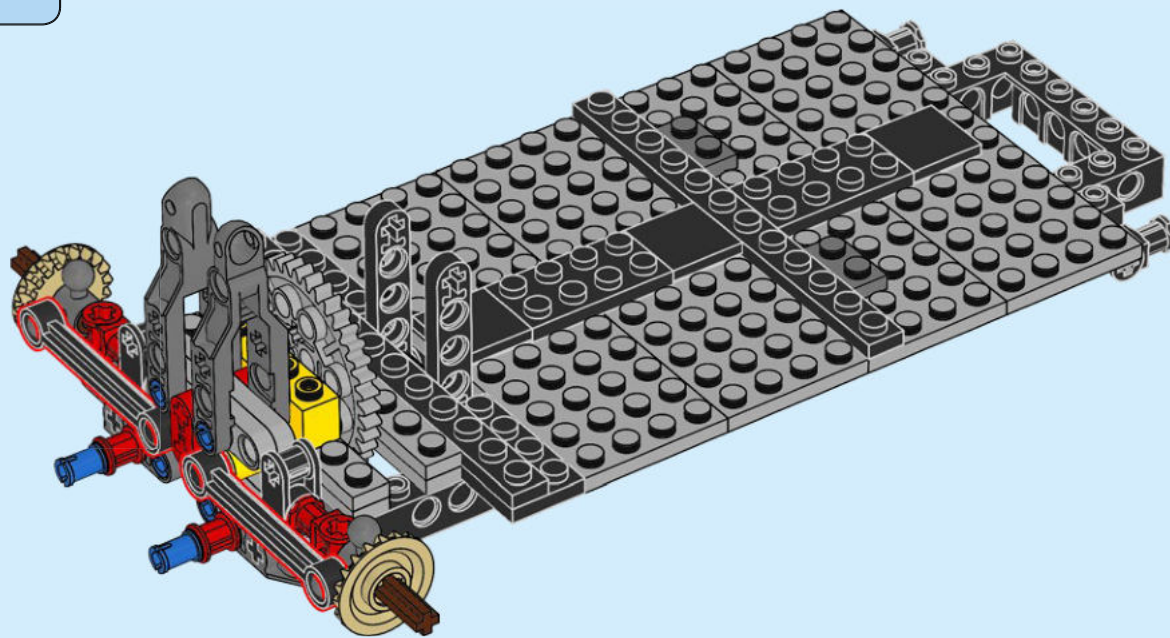



2x

27

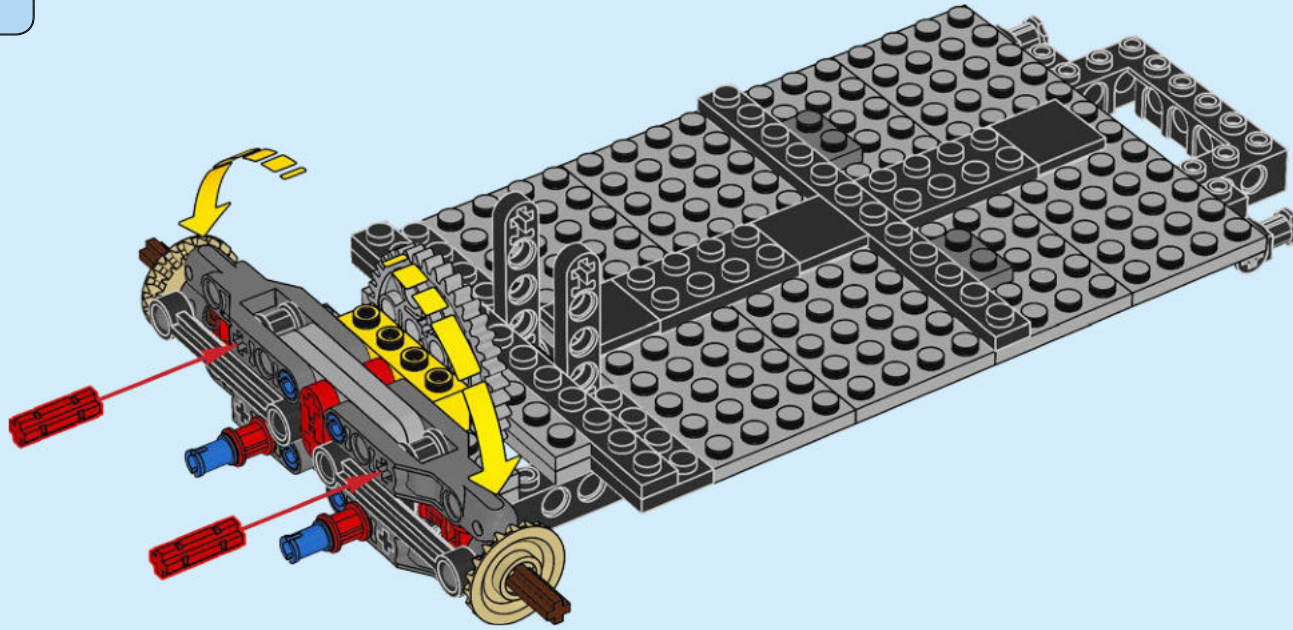

2x



2x

28

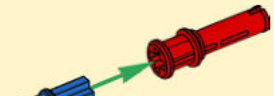
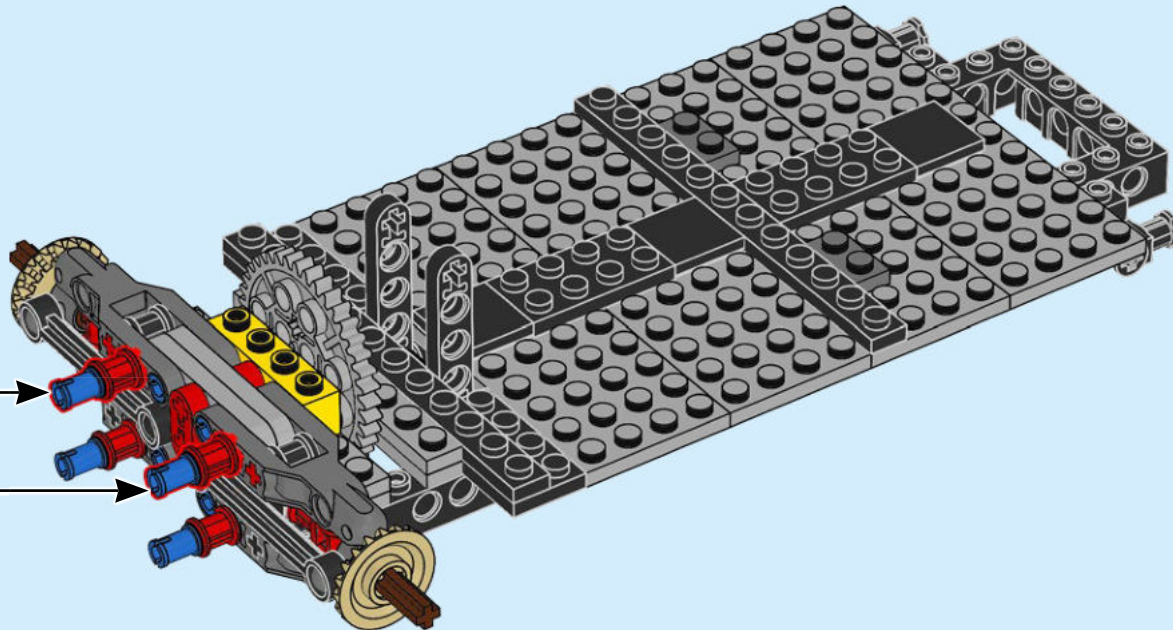

2x

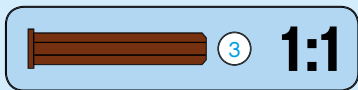
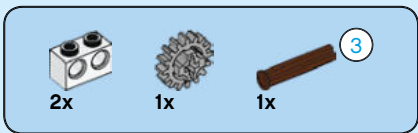

29

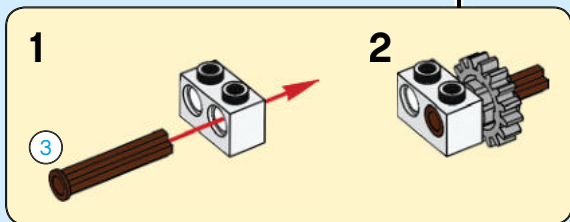
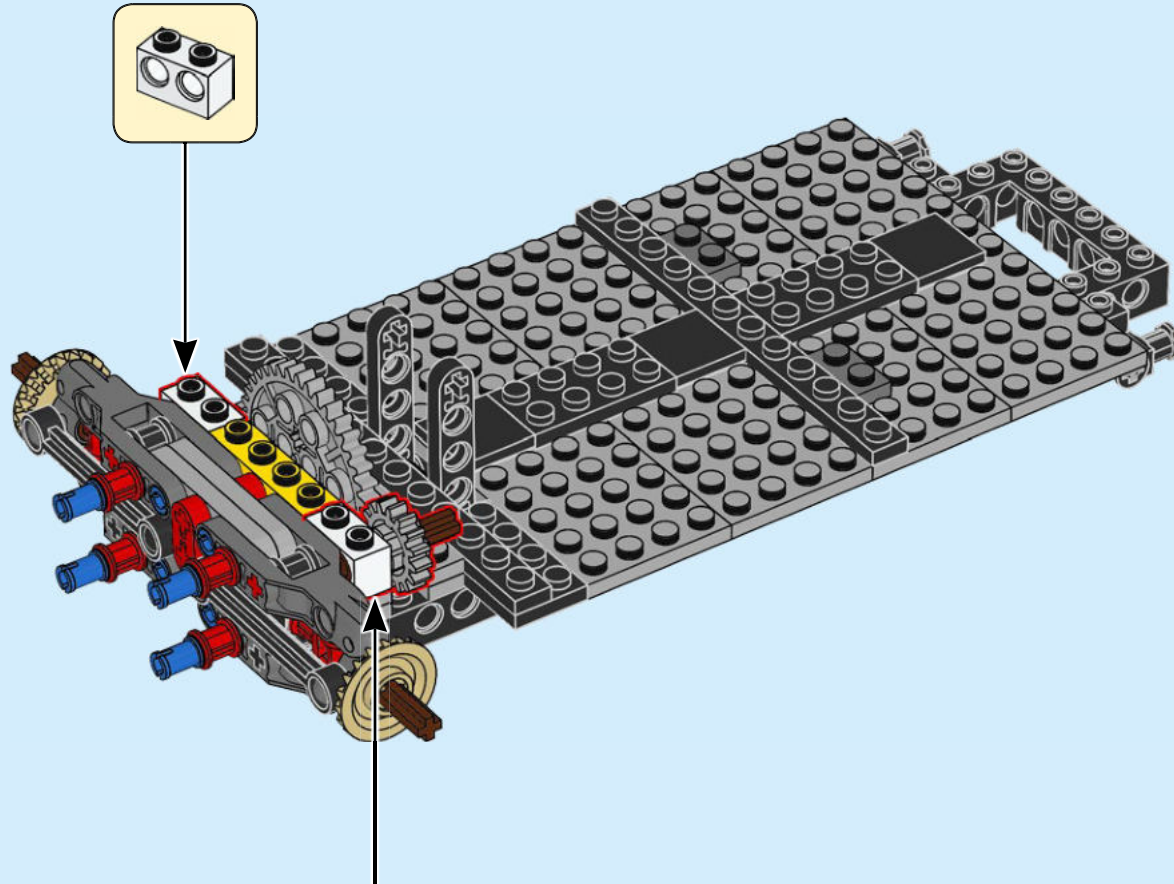

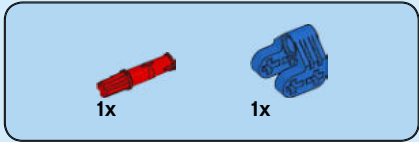
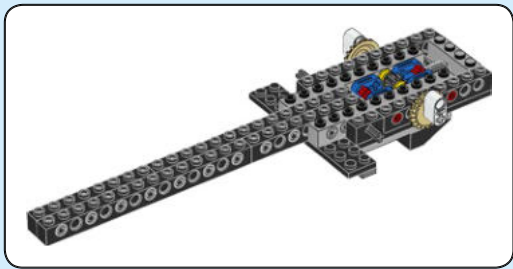

30

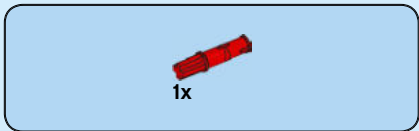

31

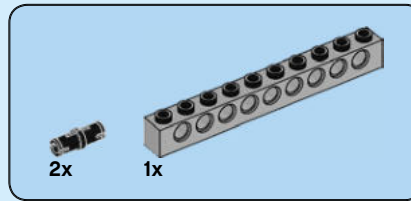
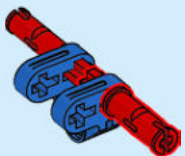

32

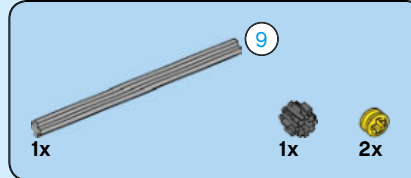
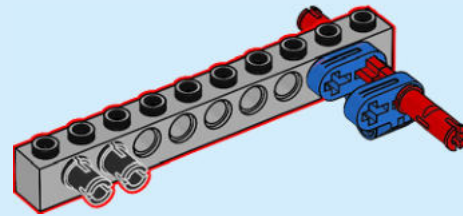

33

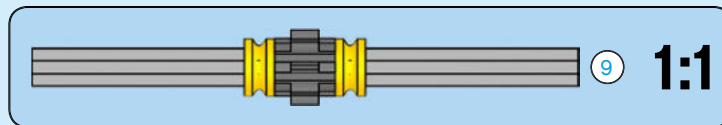
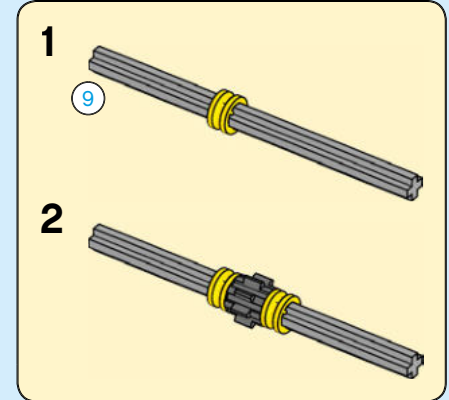
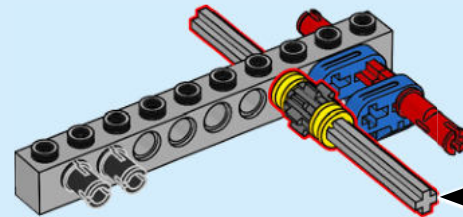

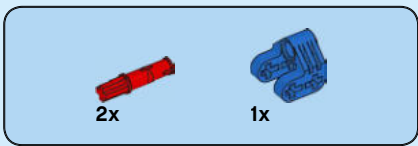

34

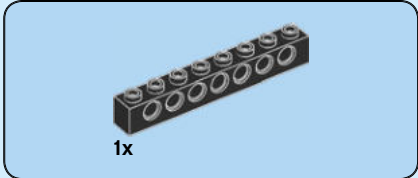
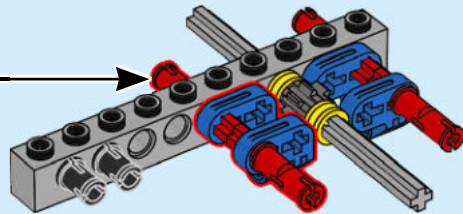
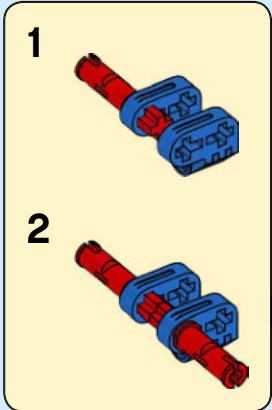

35

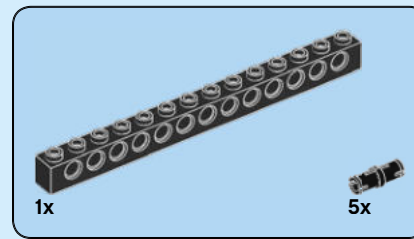
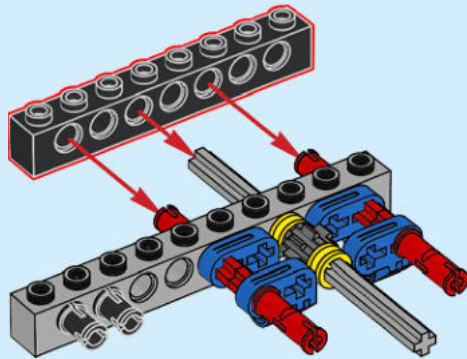

36

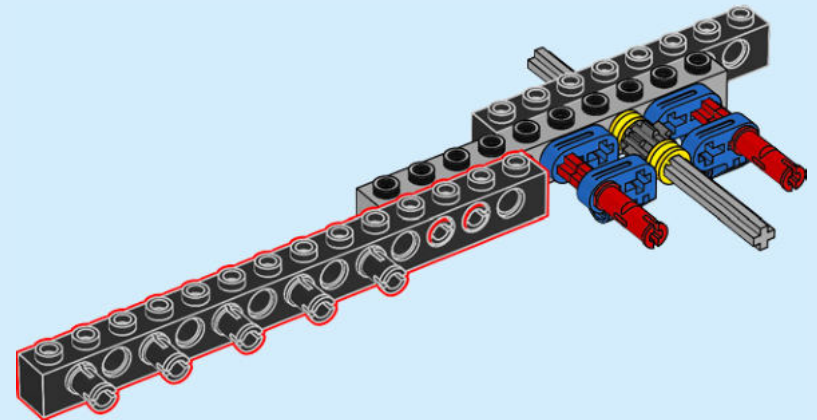

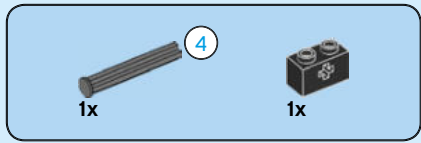

37

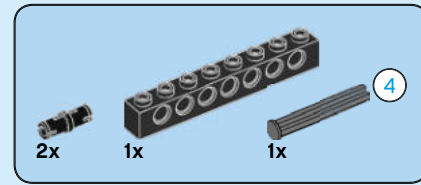
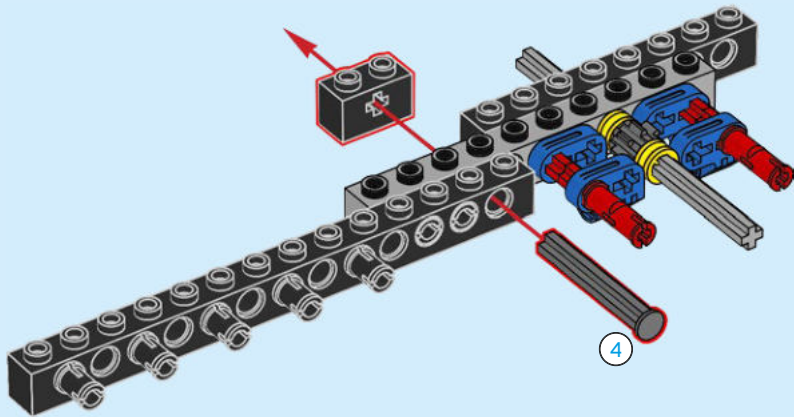
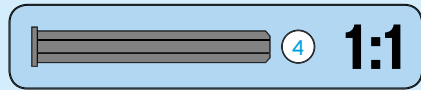

38

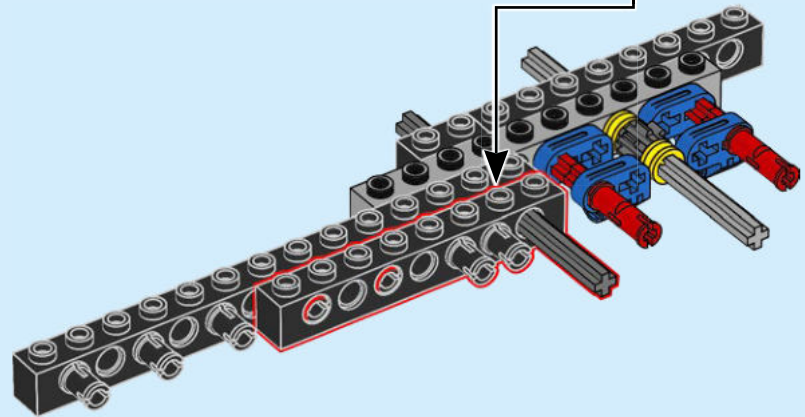
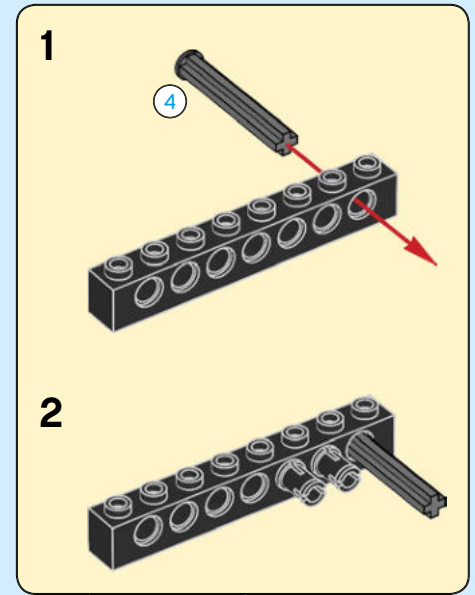

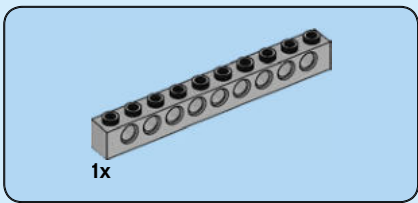

39

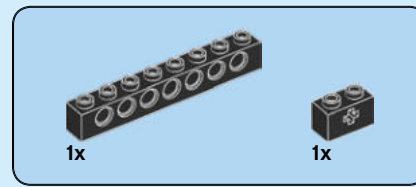
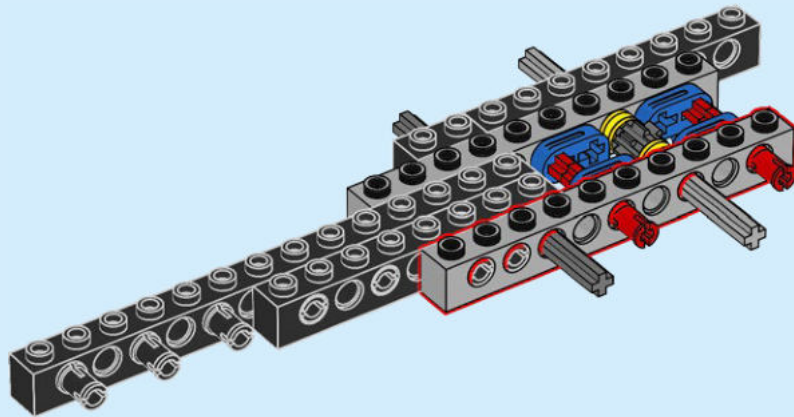

40

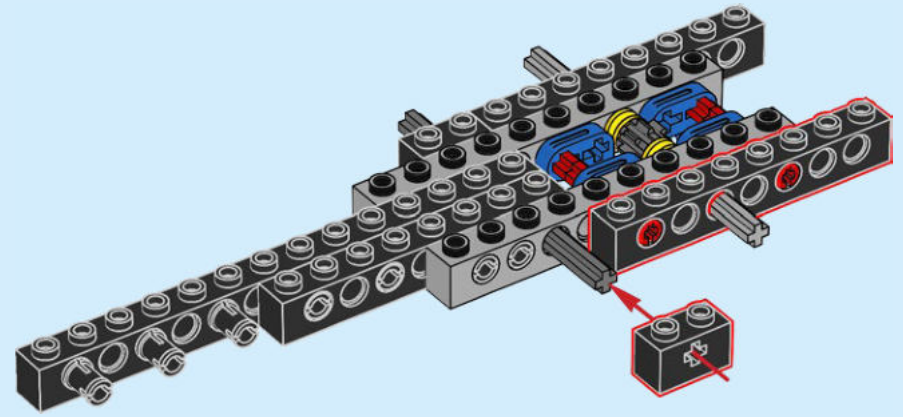

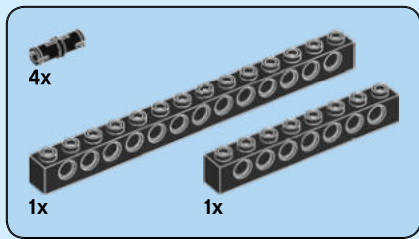

The Mustang is the car driven by Steve McQueen in the iconic car chase in the 1968 movie *Bullitt*.

41

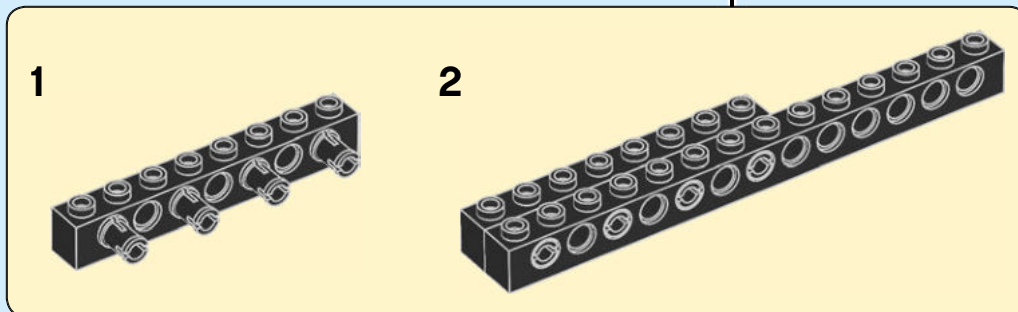
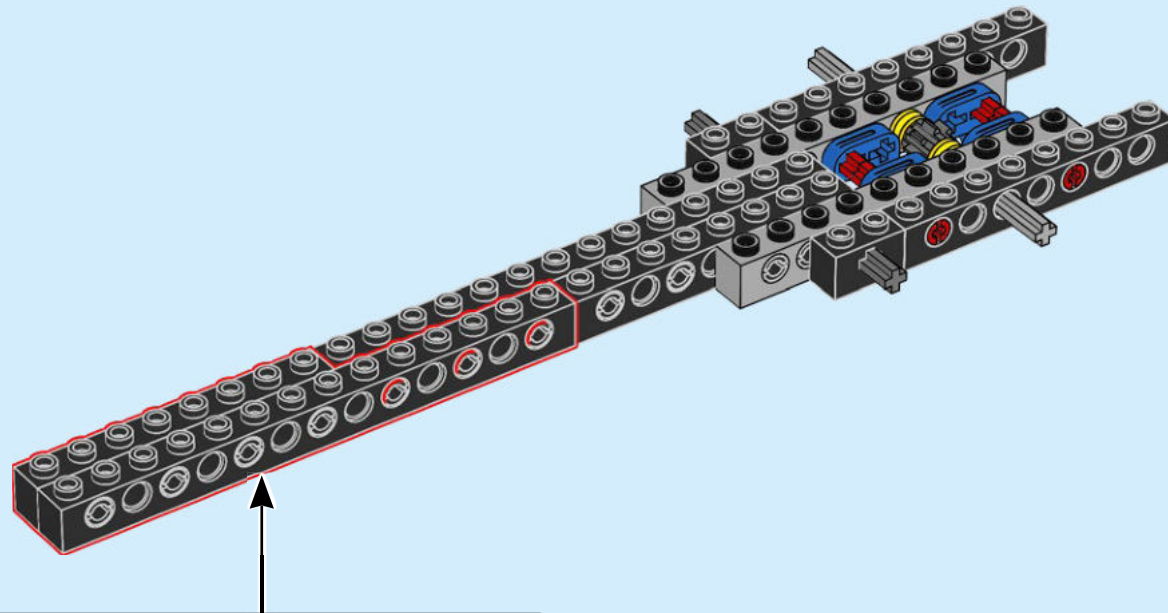

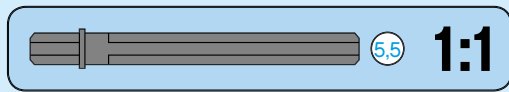
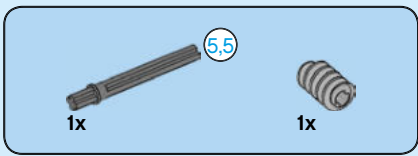

42

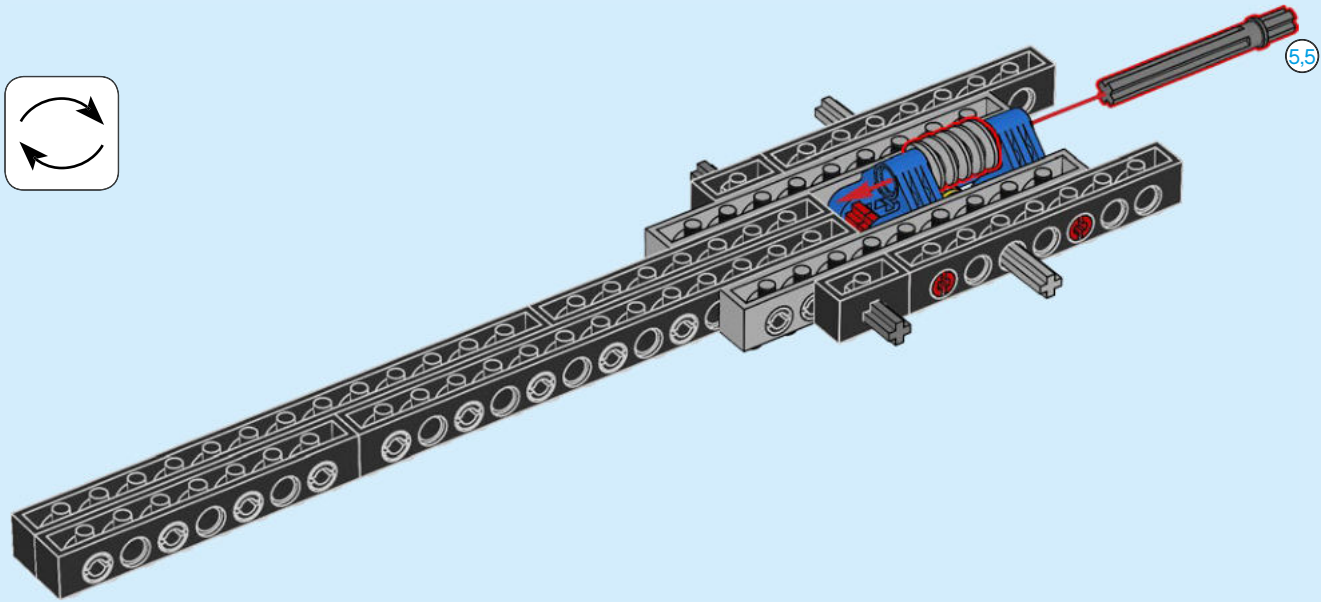
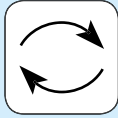

43

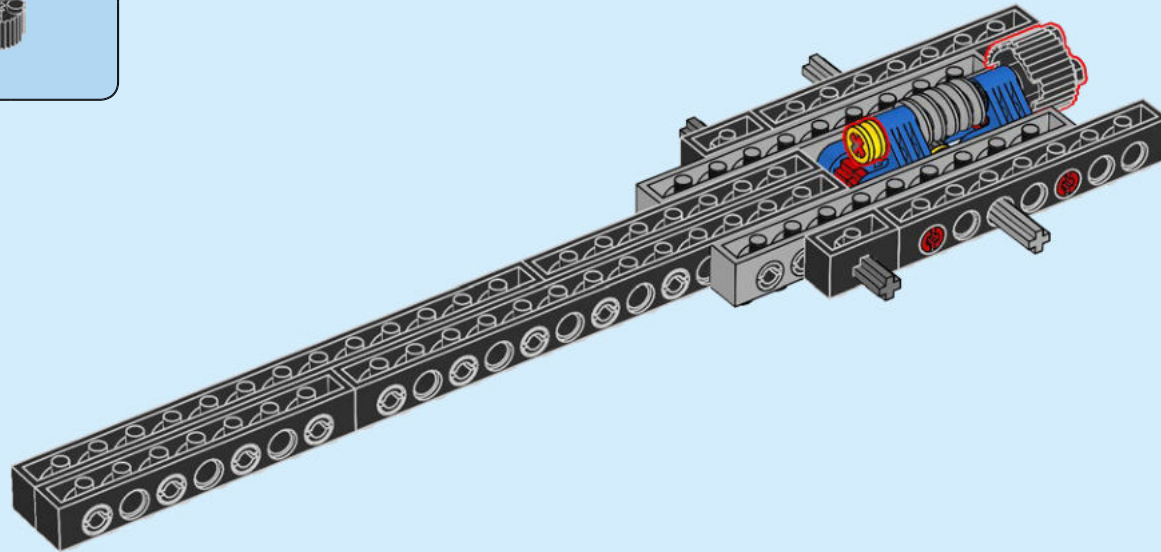

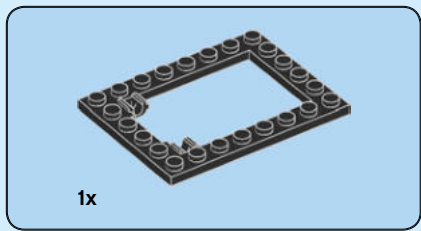

44

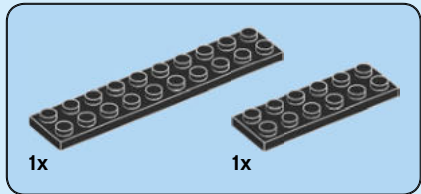
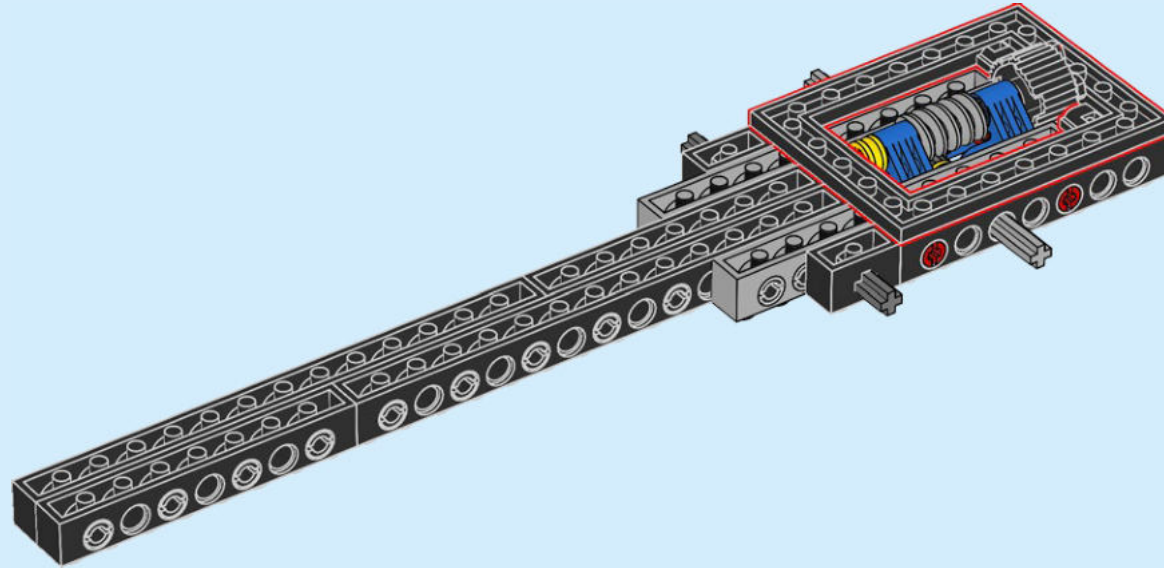

45

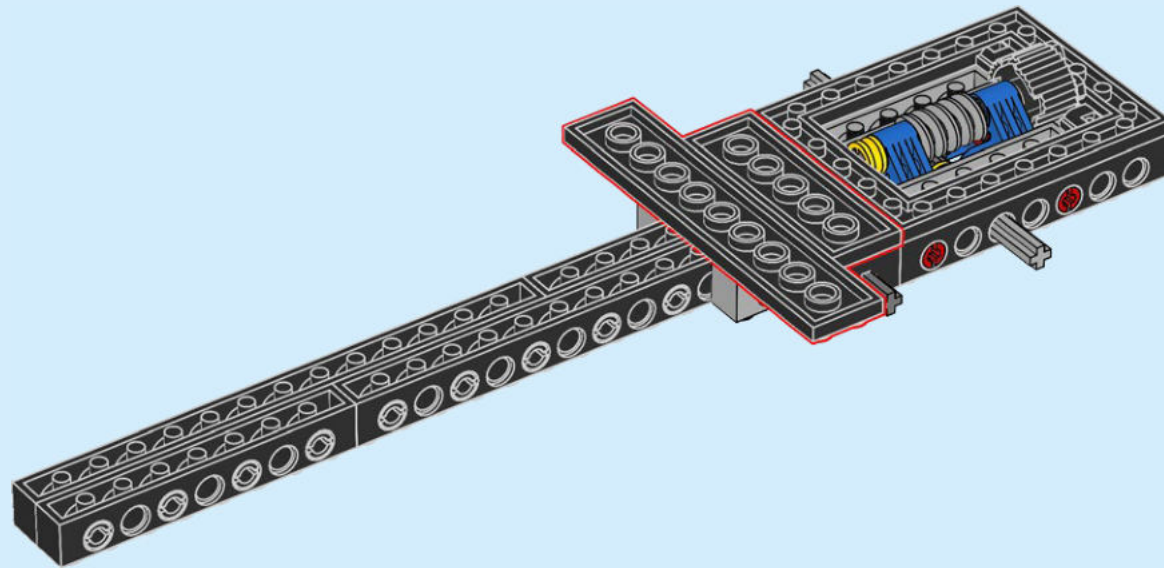

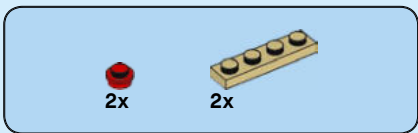

46

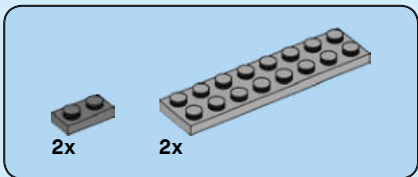
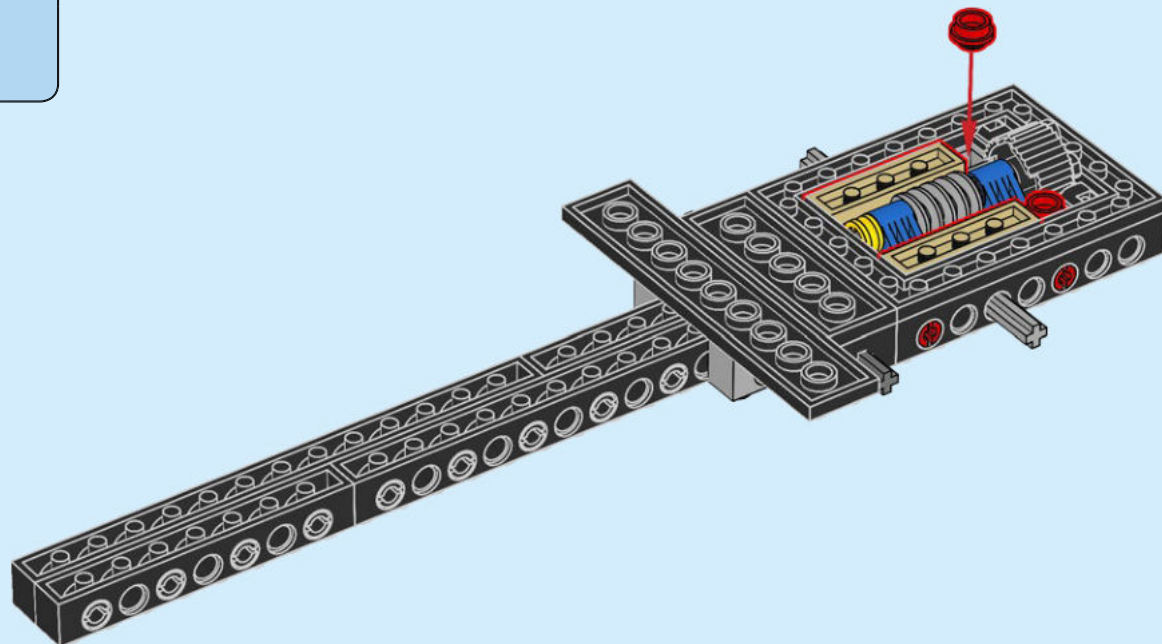

47

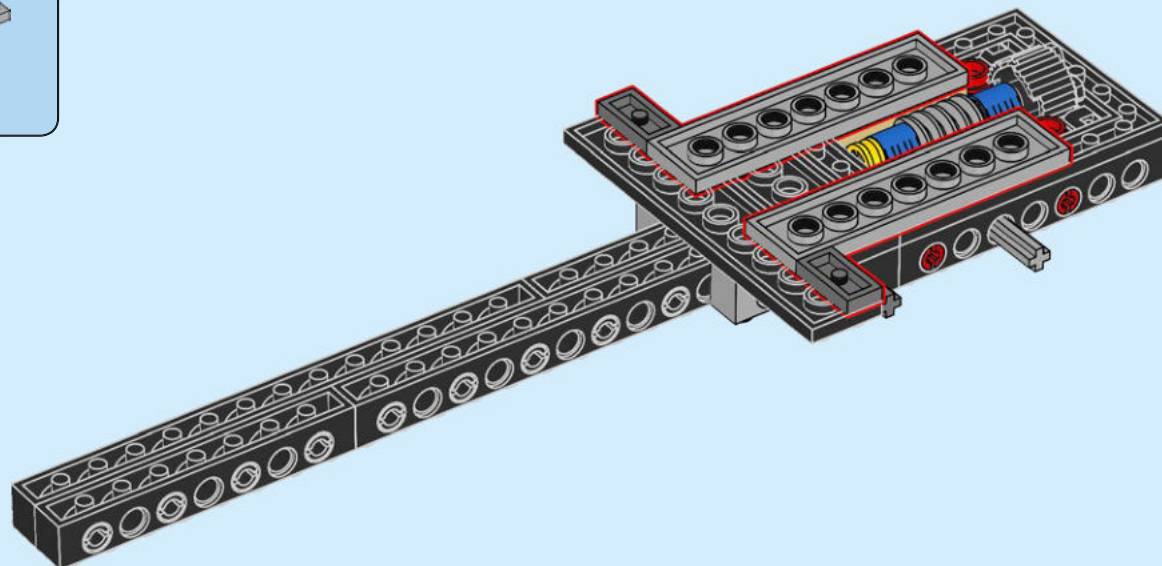

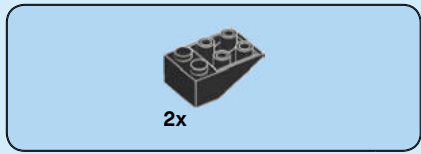

48

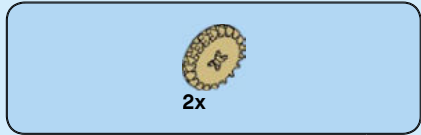
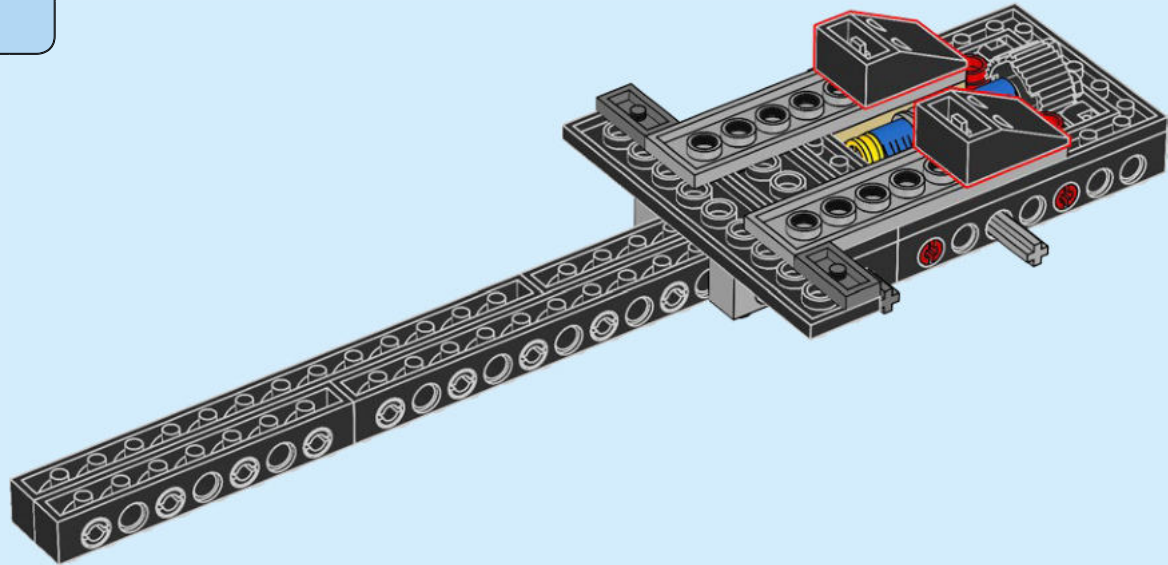

49

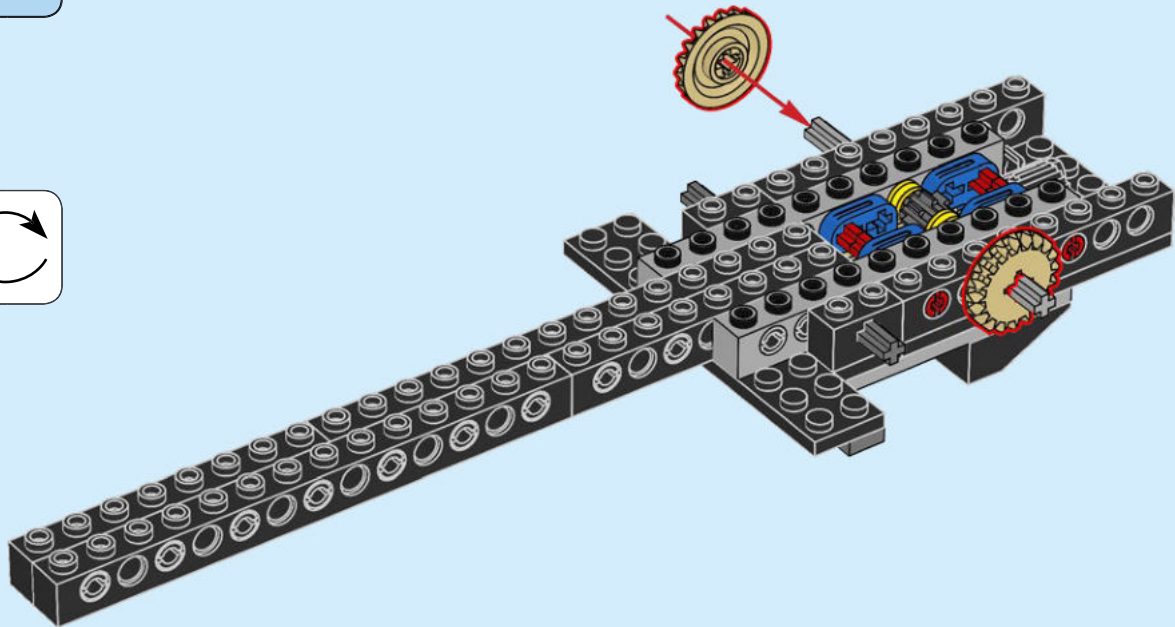
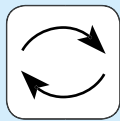

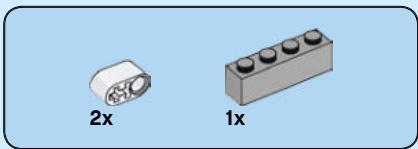

50

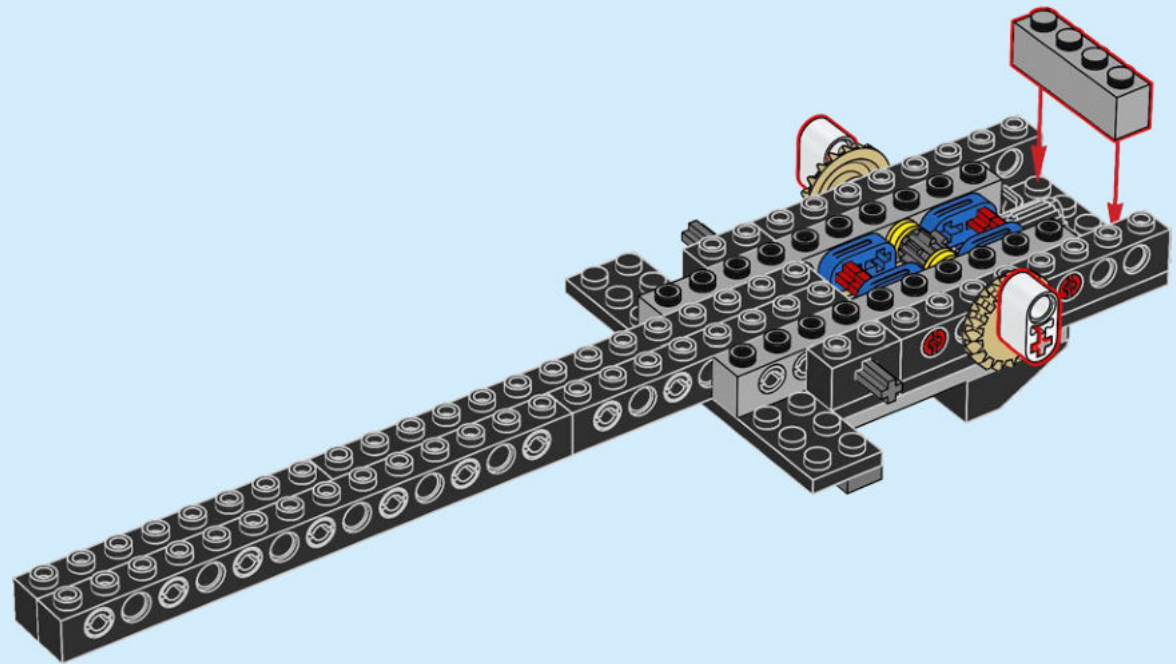

51

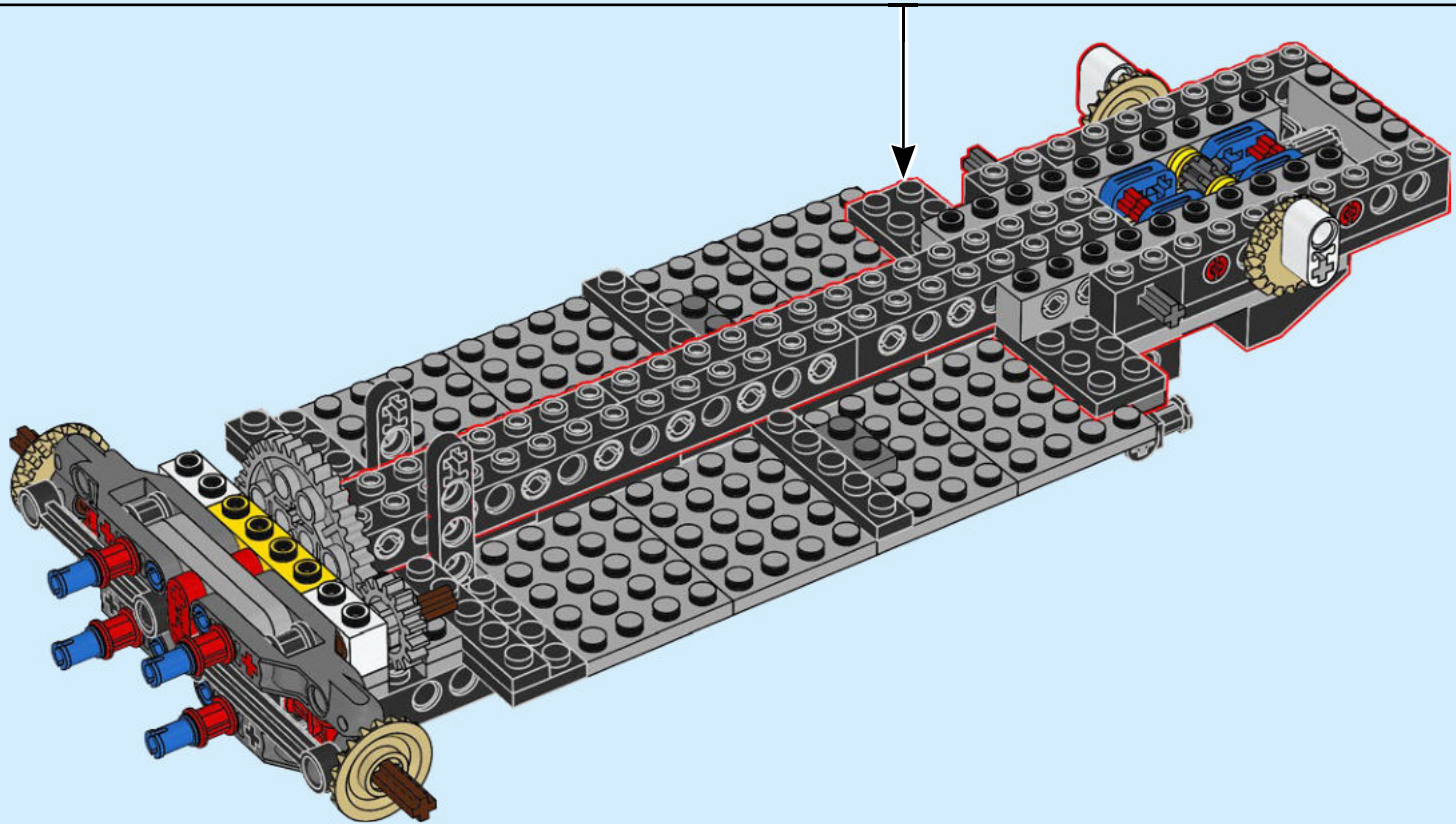



52

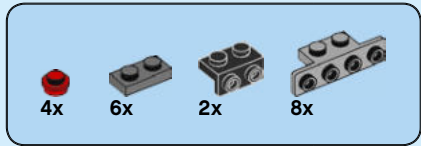
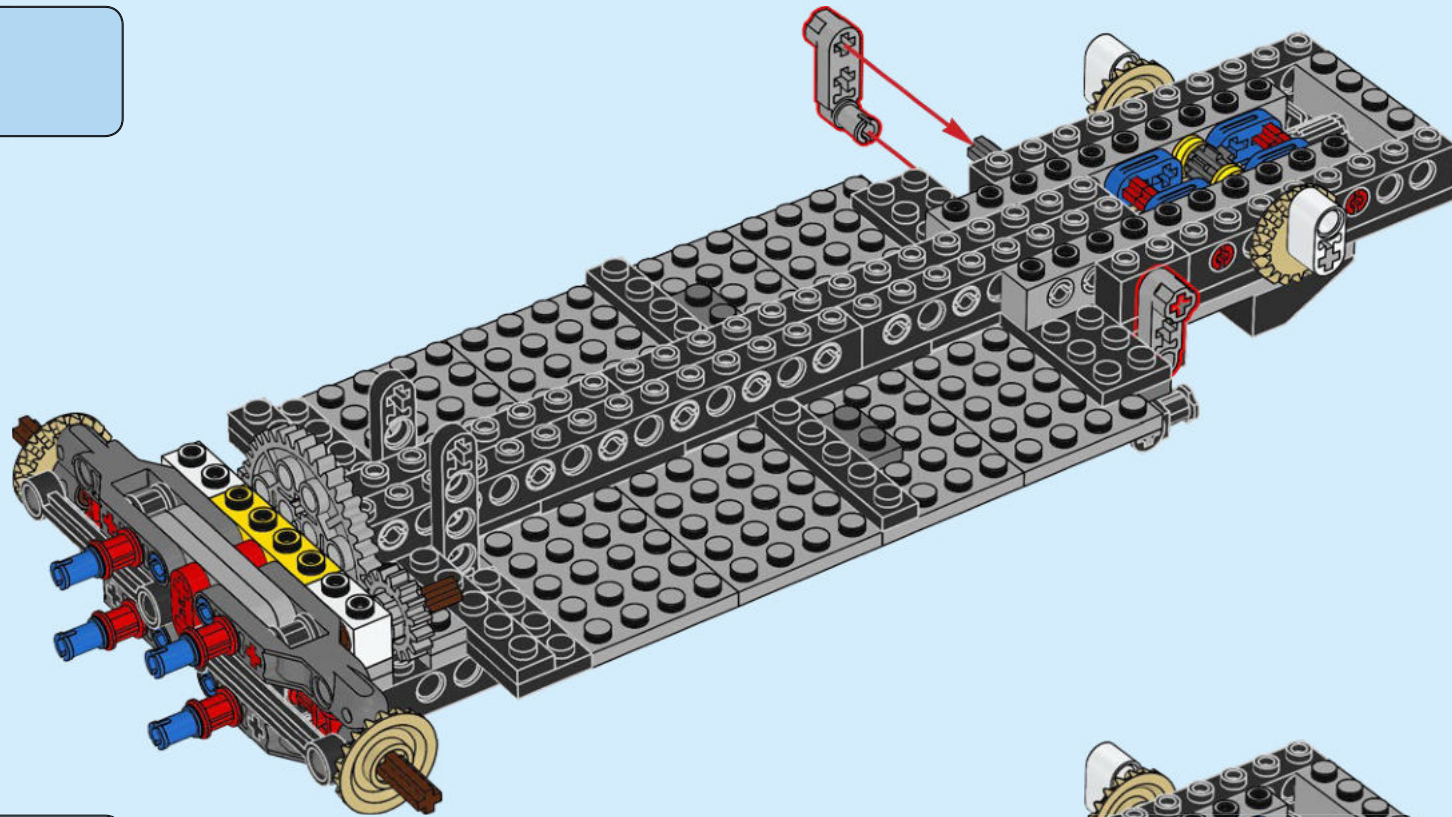

53

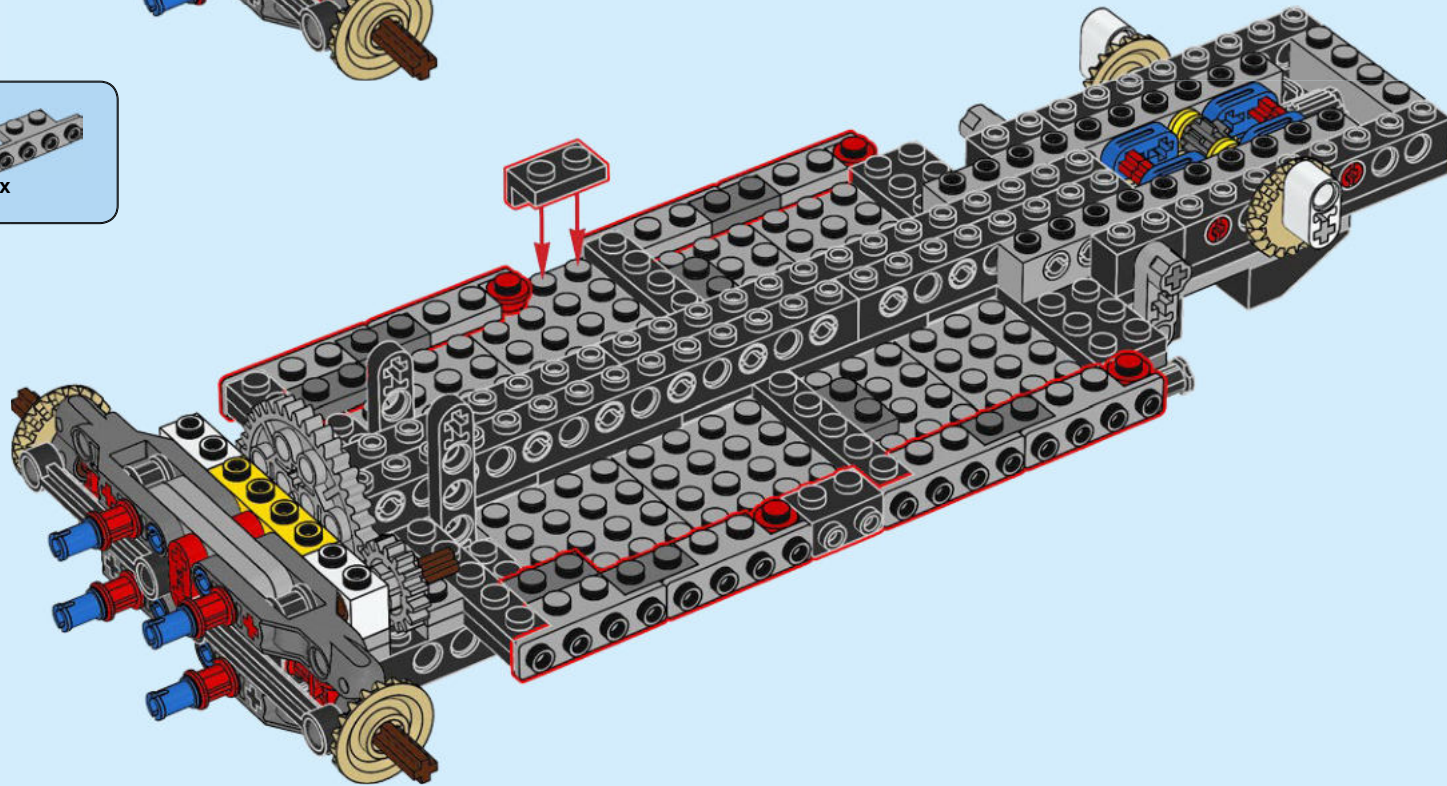

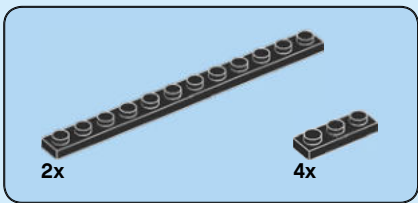

54

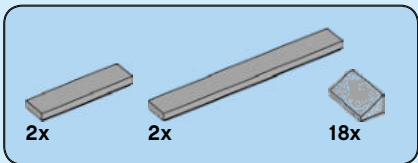
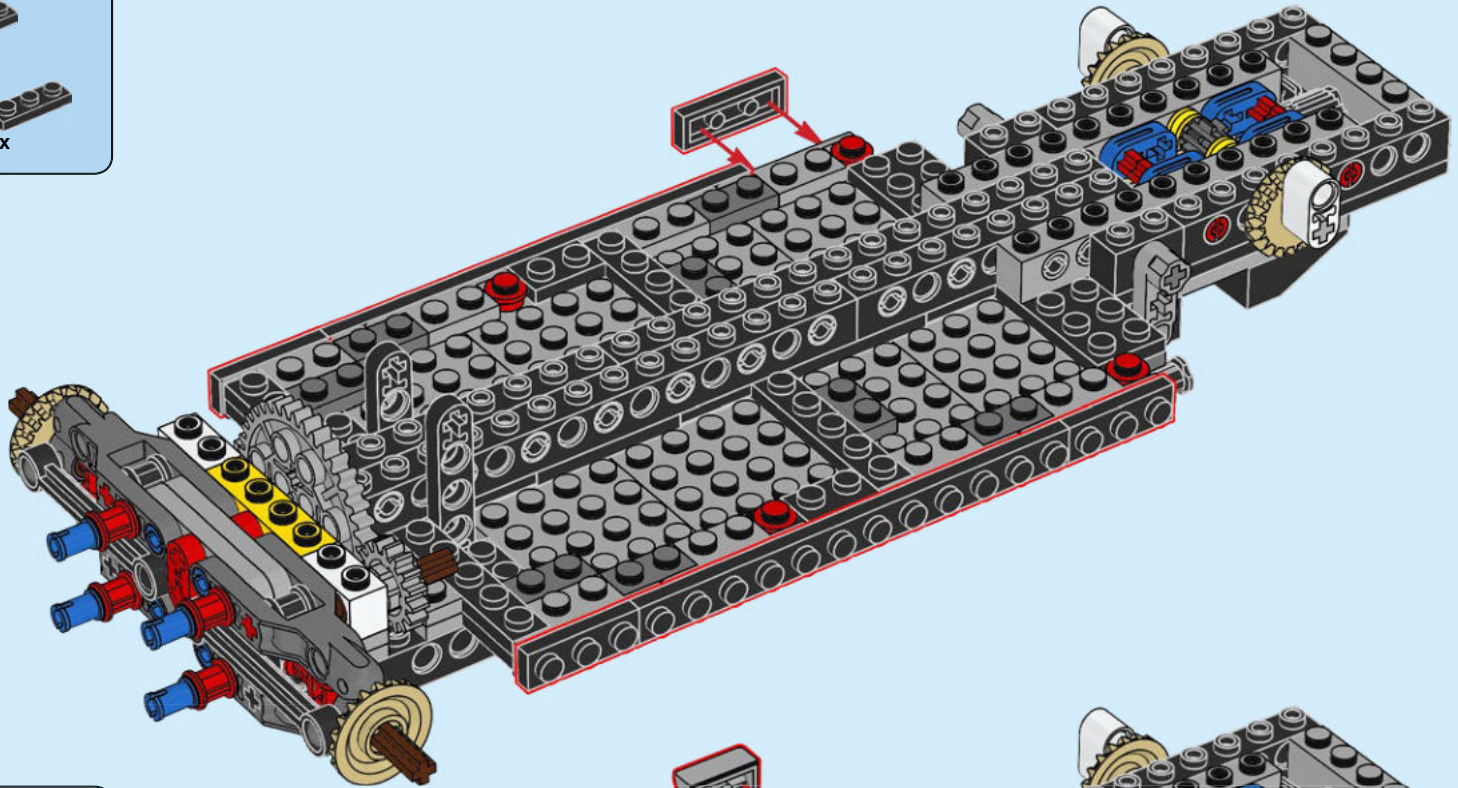

55

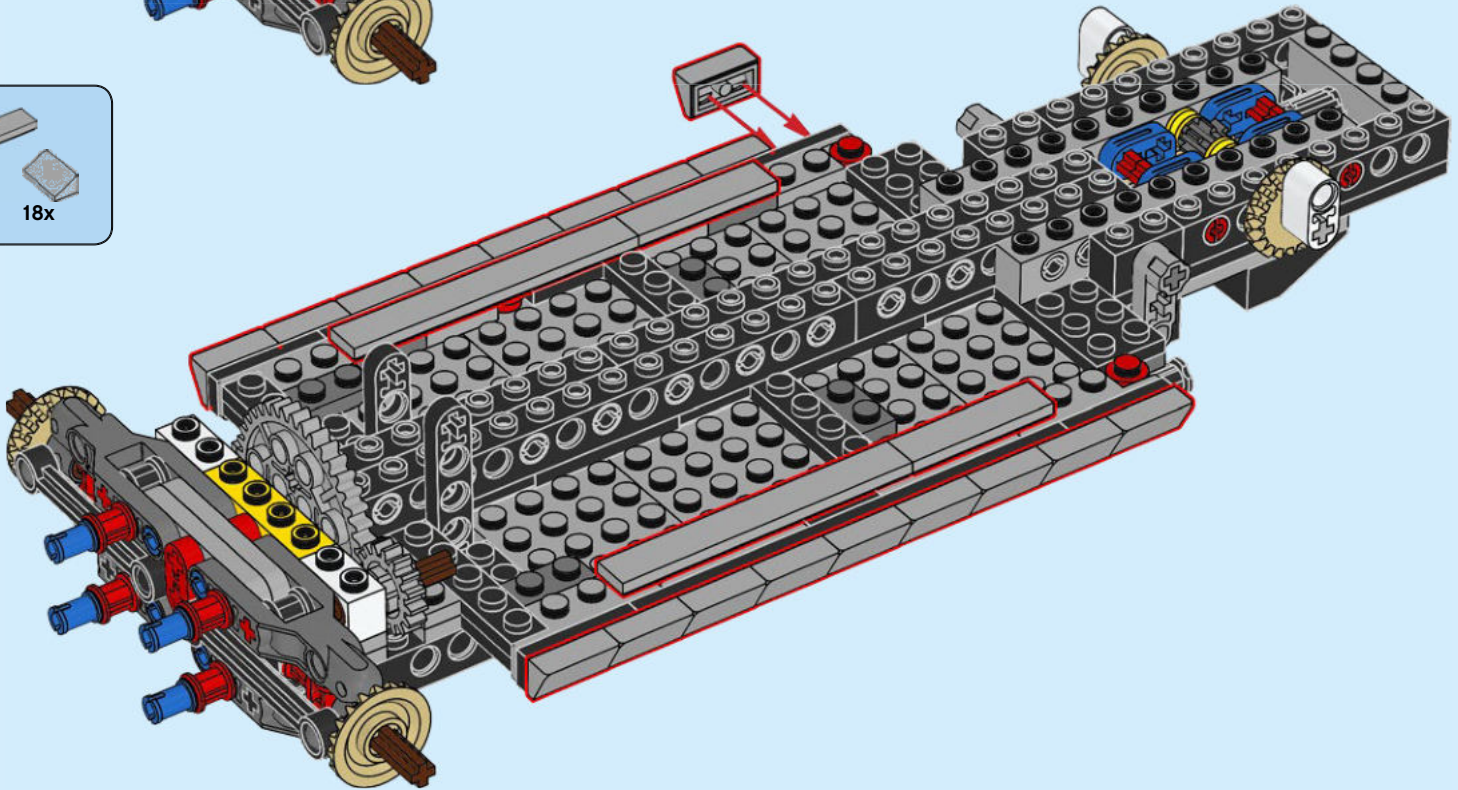

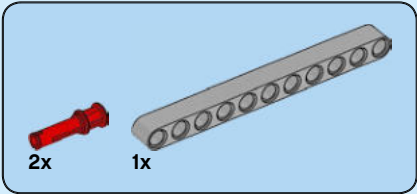
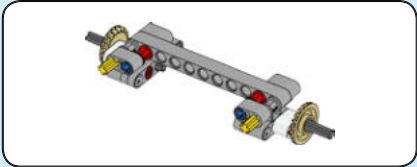
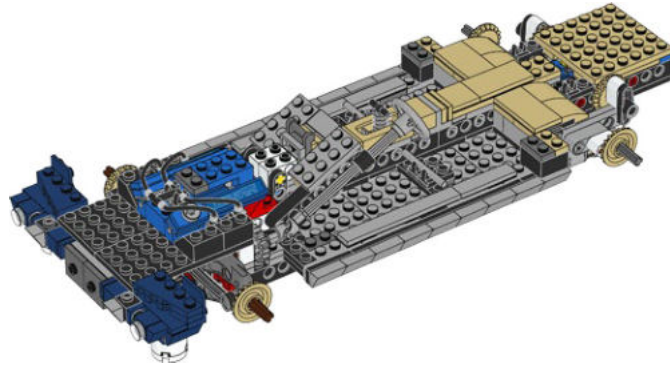
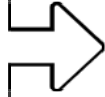
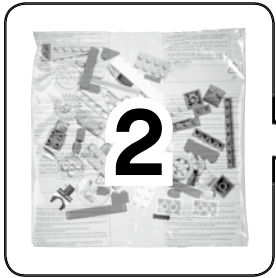

56

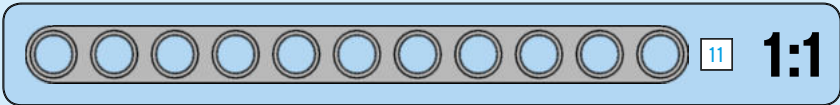
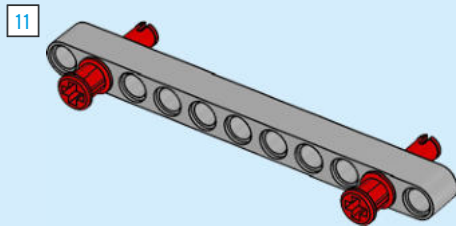

57

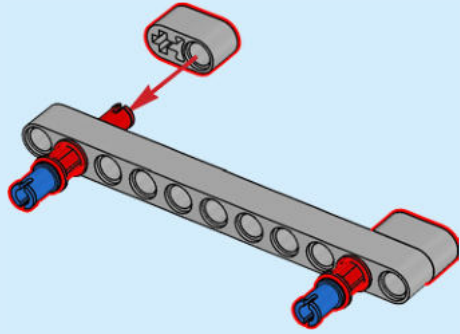

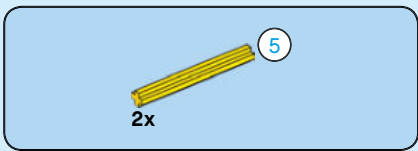

58

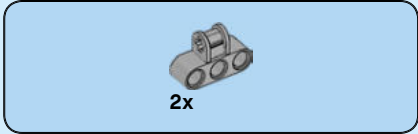
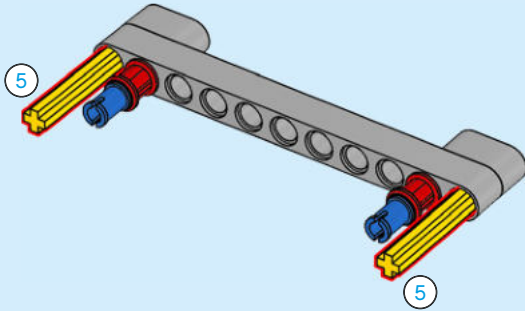

59

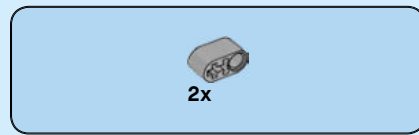
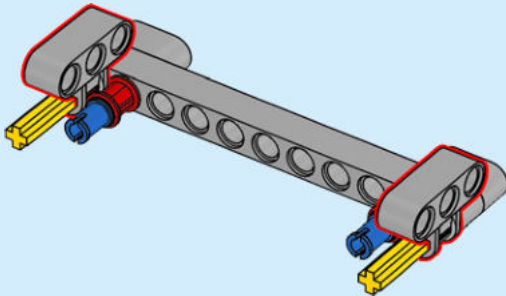

60

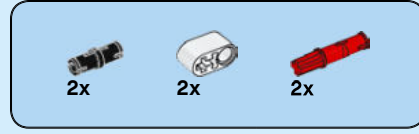
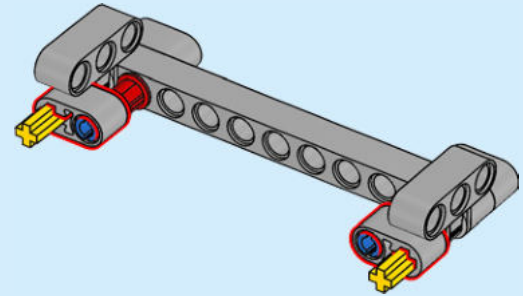

61

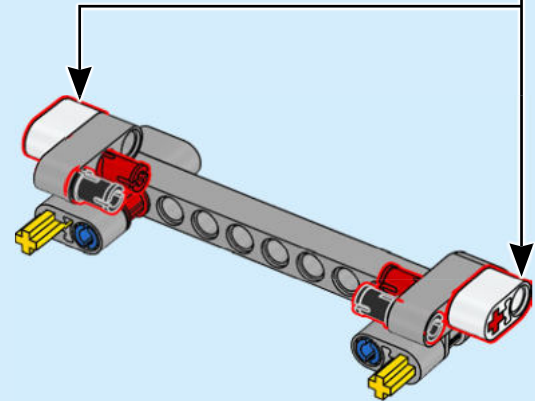
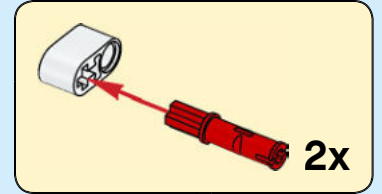

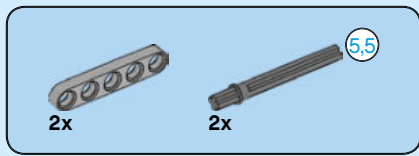

62

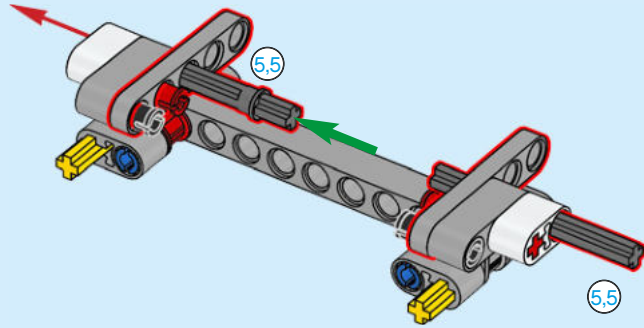

63

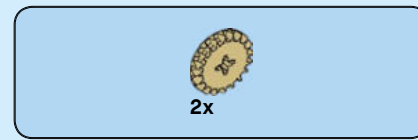
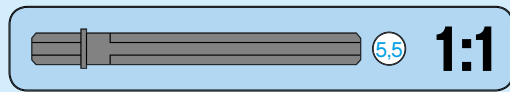
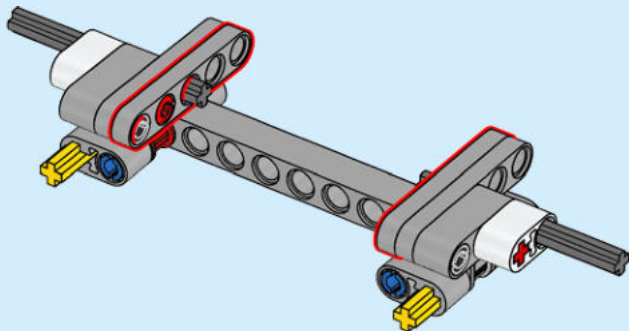

64

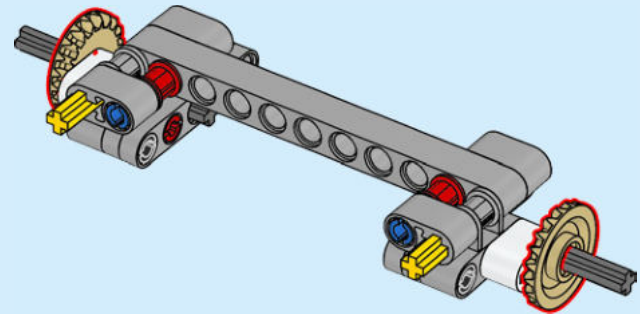
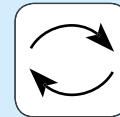

65

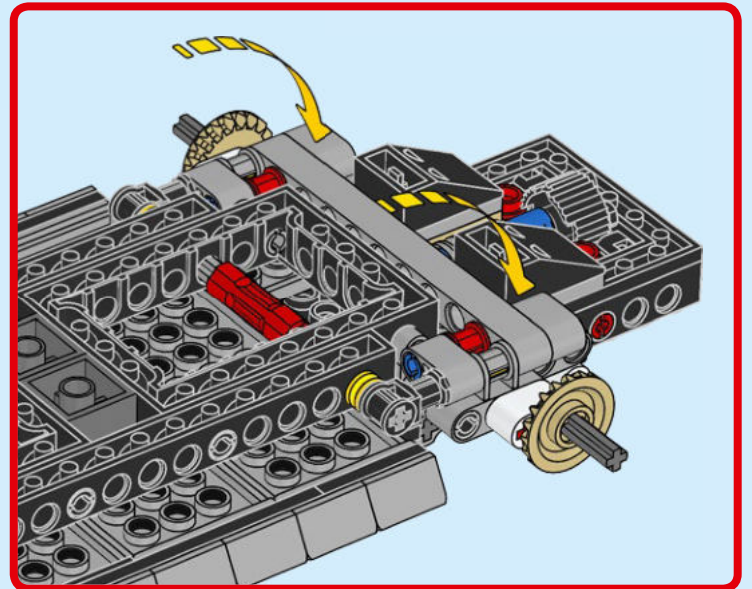
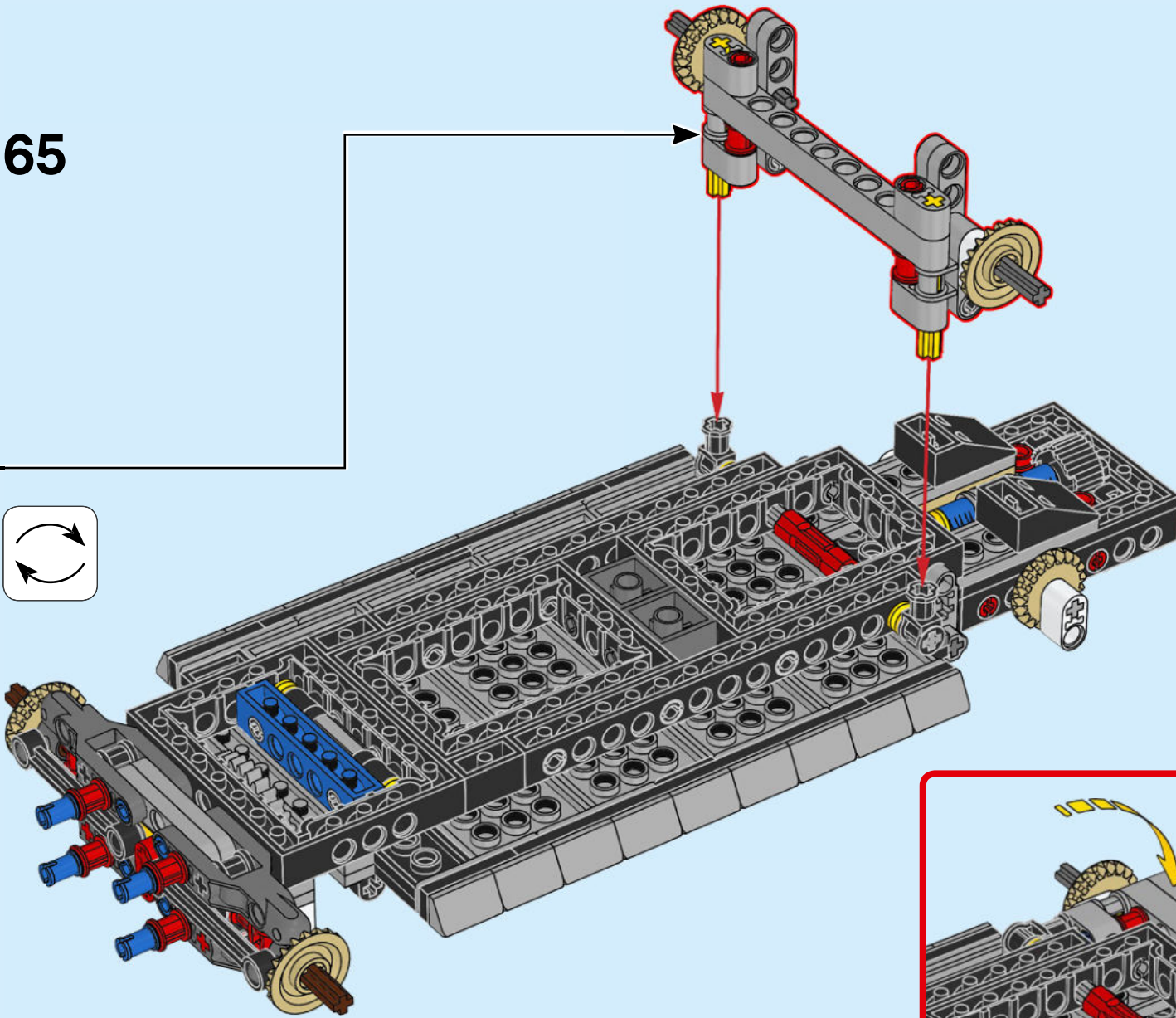
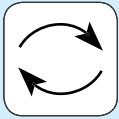

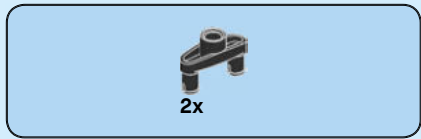

66

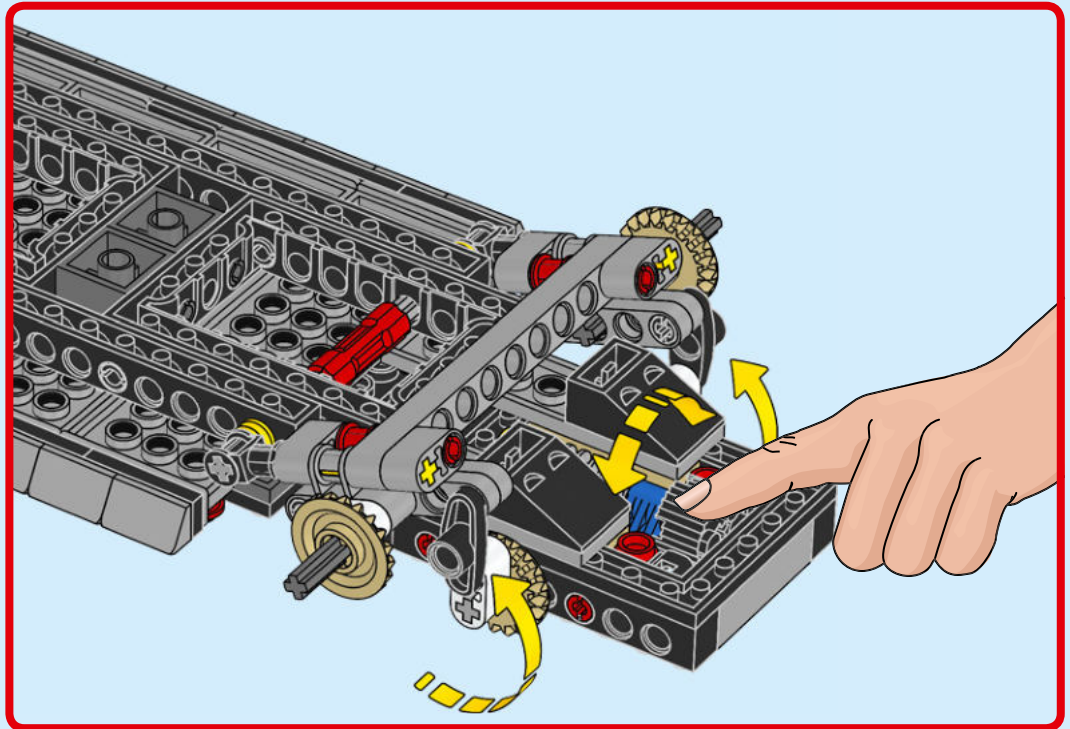
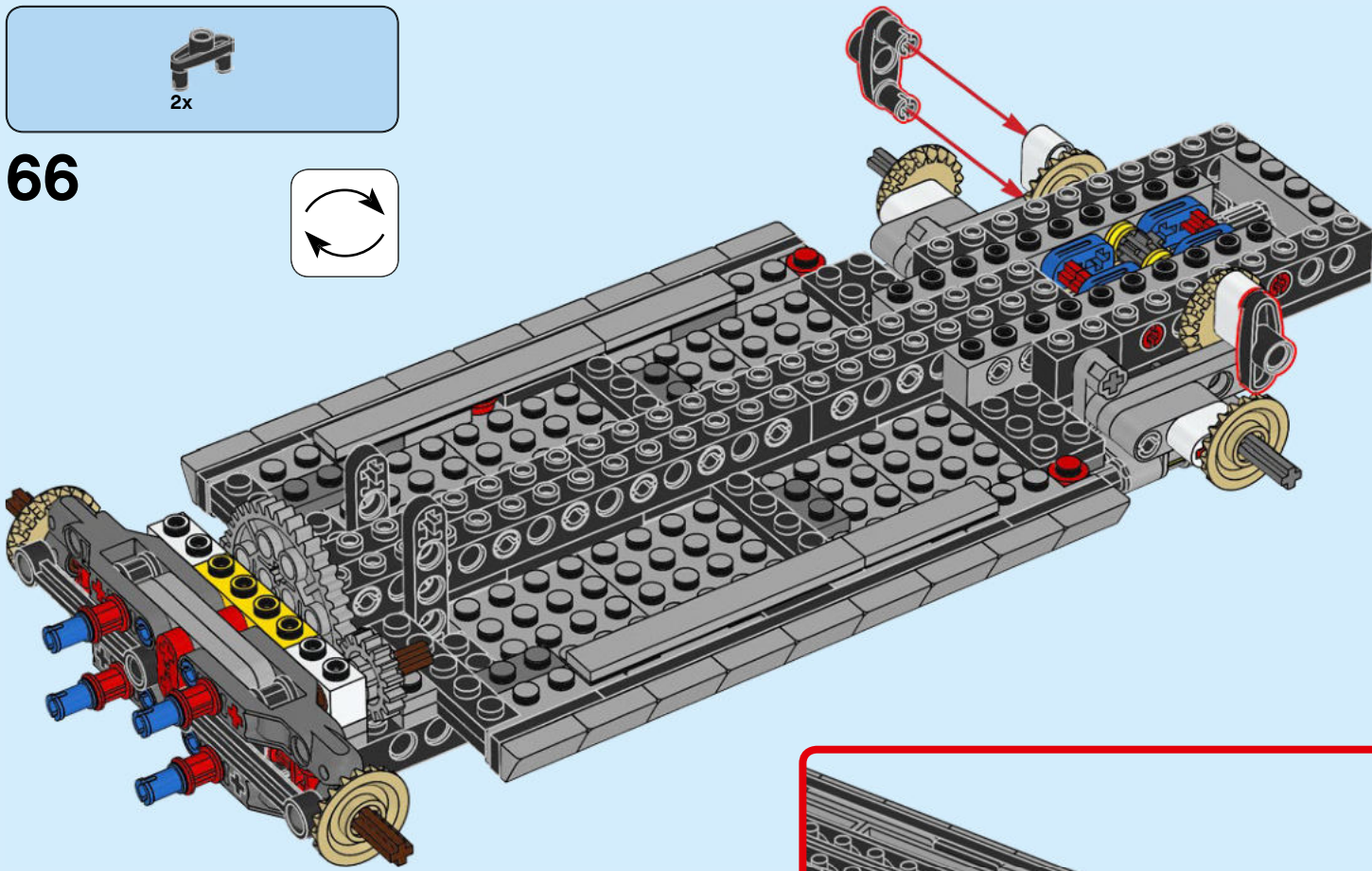
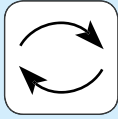

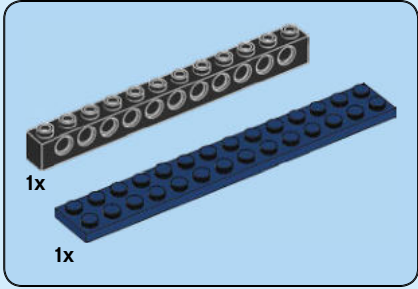
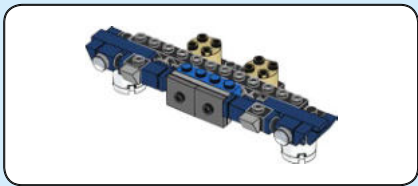

67

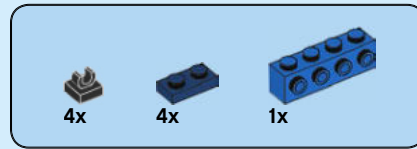
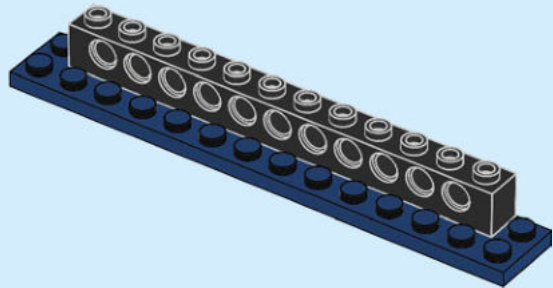

68

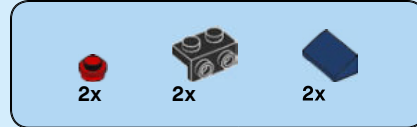
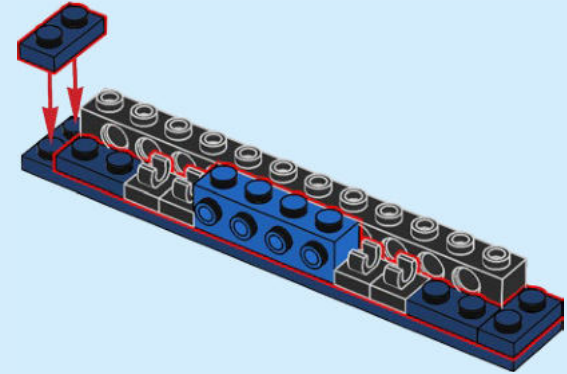

69

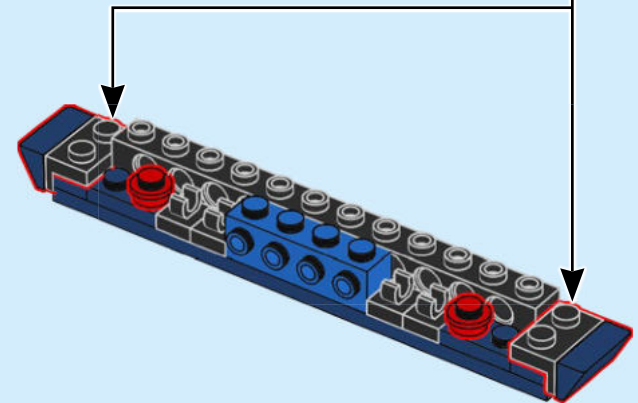
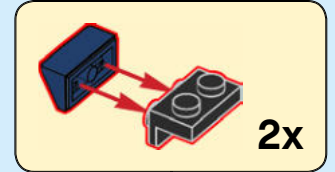



70

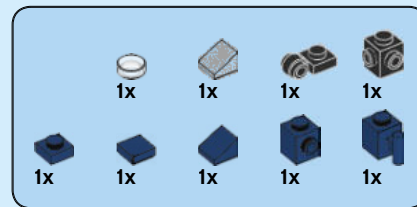
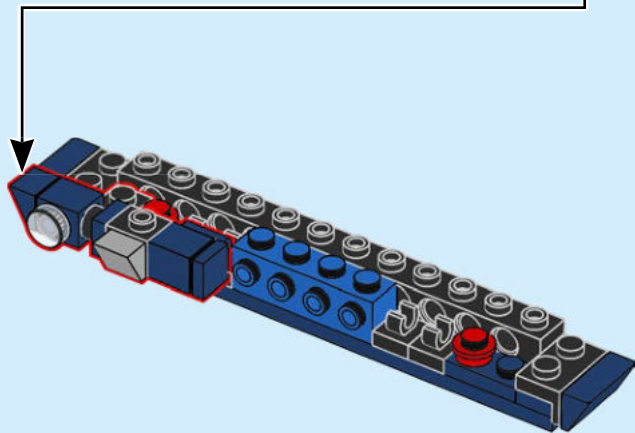
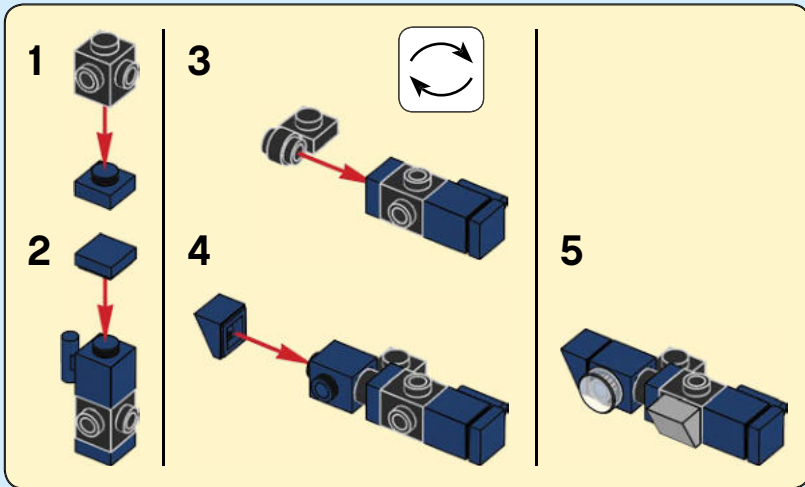

71

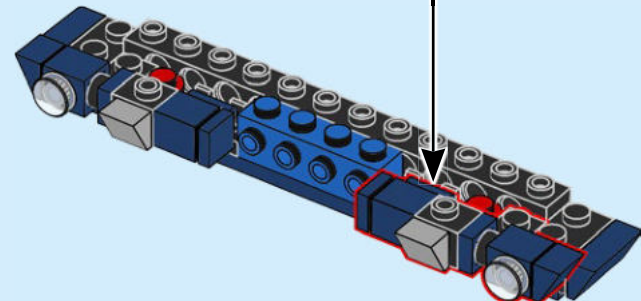
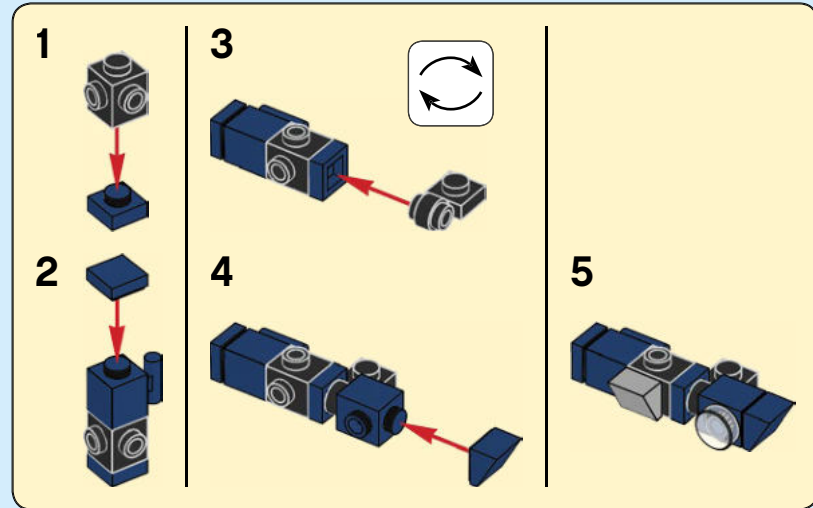



72

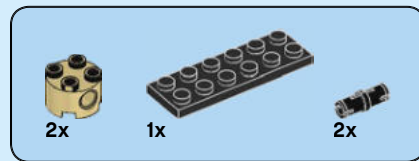
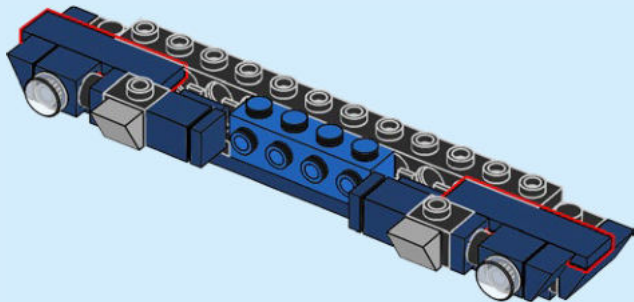

73

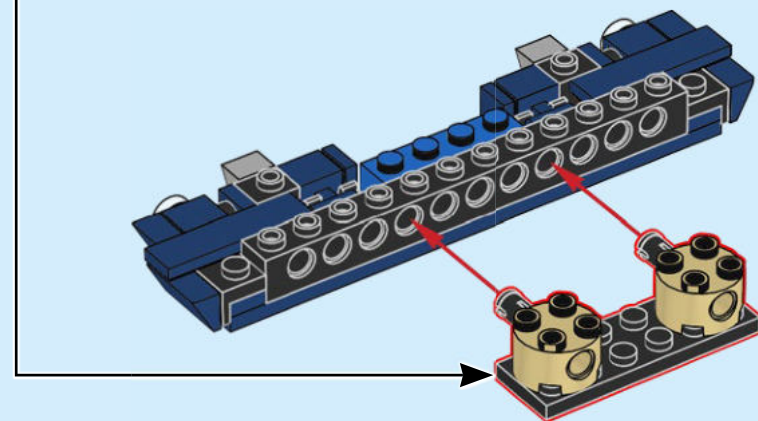
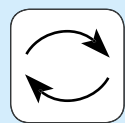
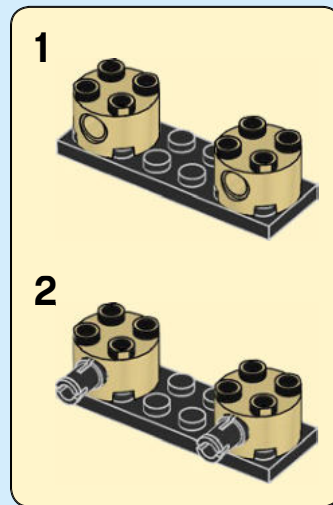

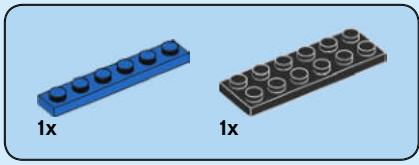

74

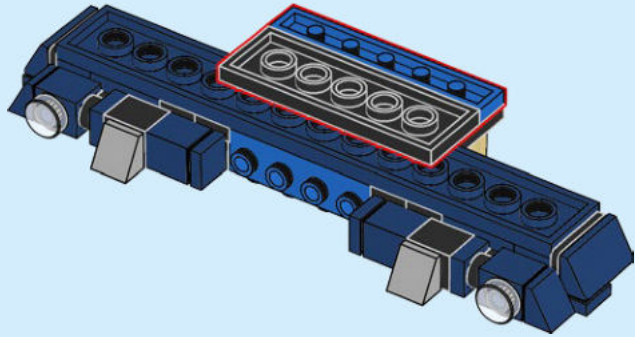
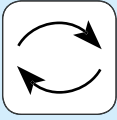

75

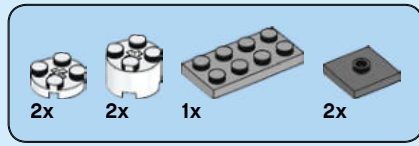
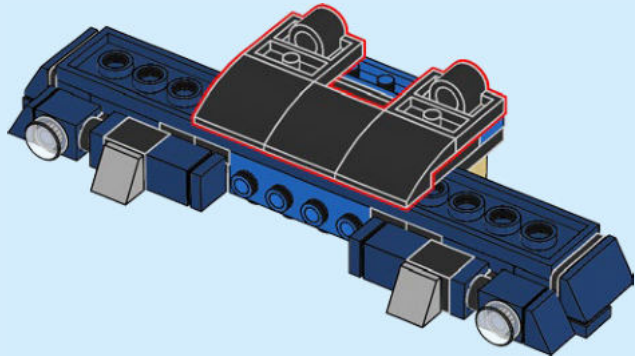

76

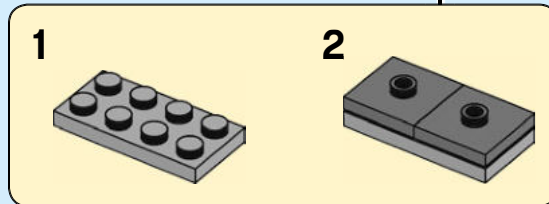
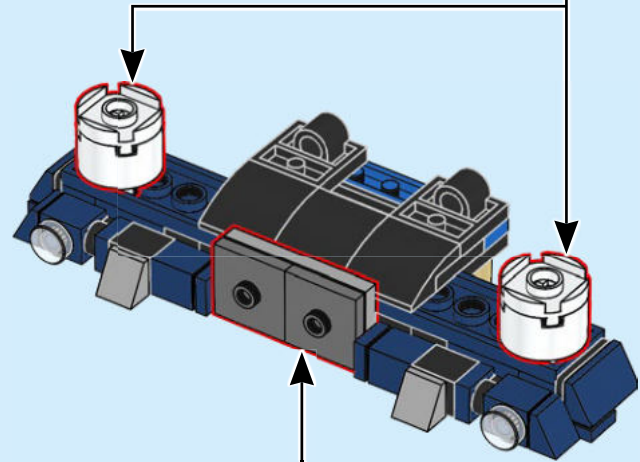
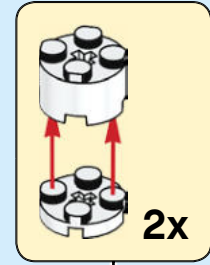

77

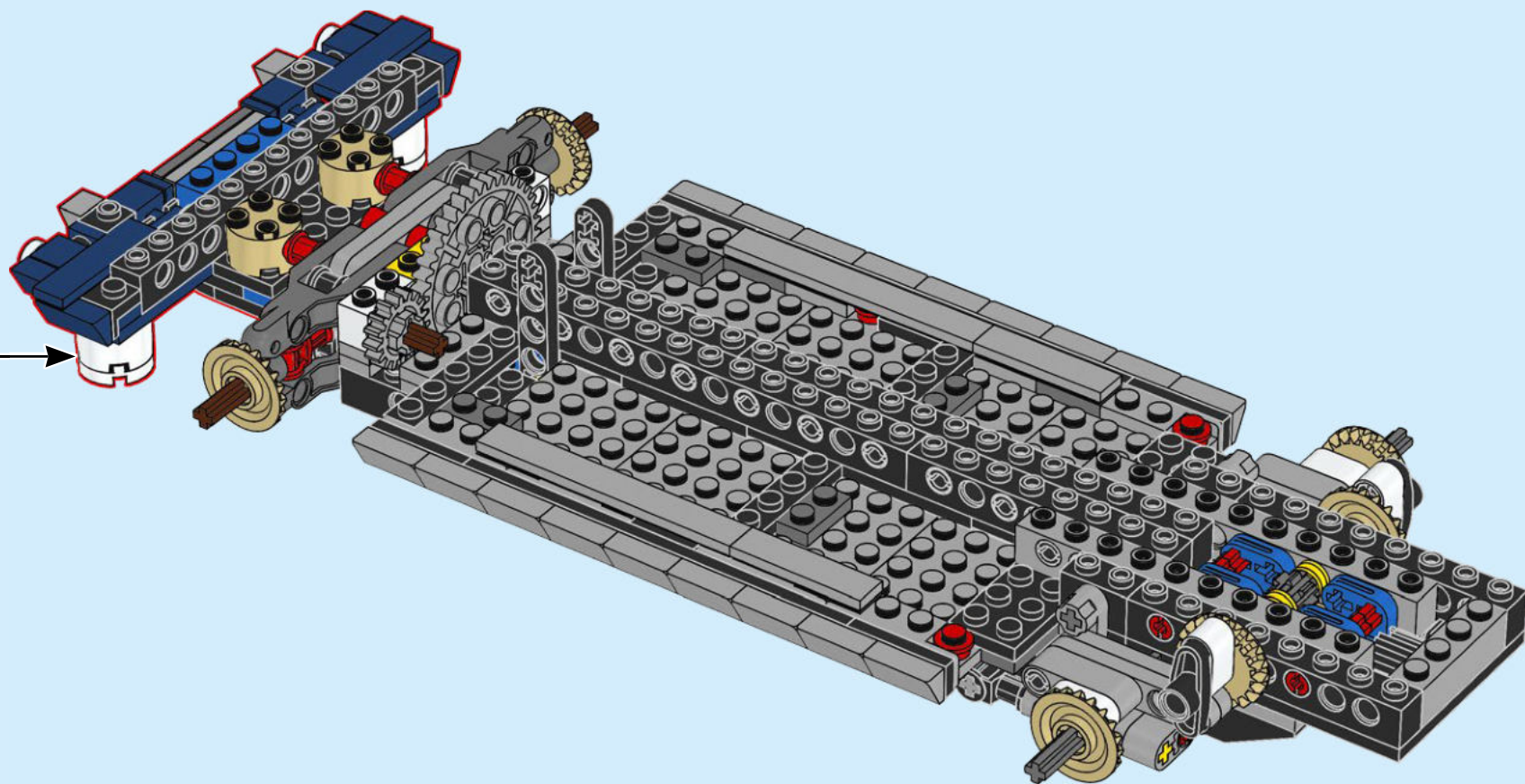

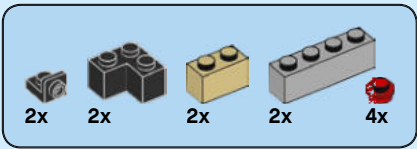

78

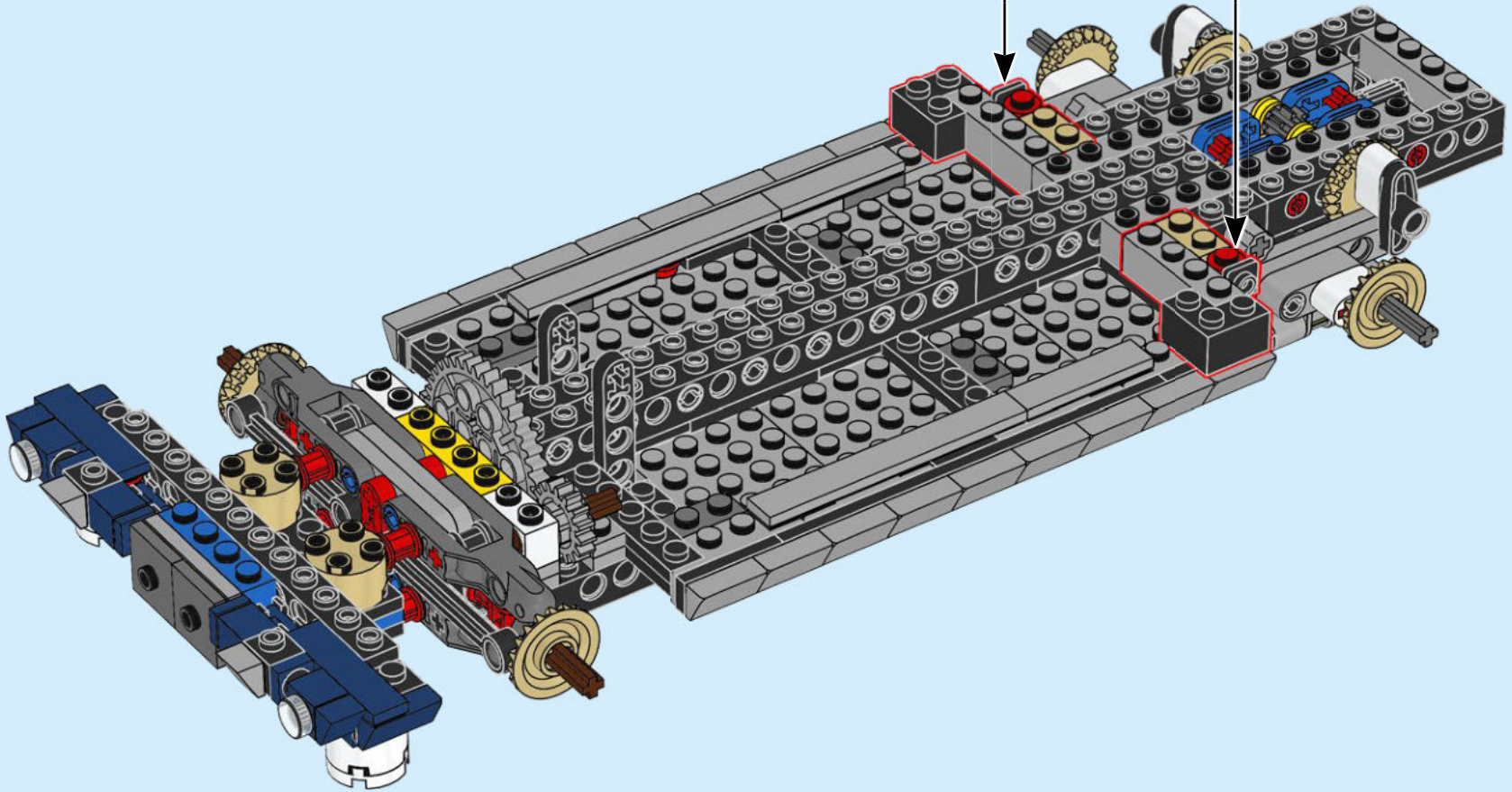
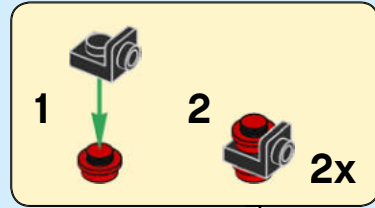

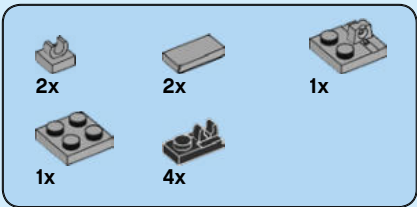

80

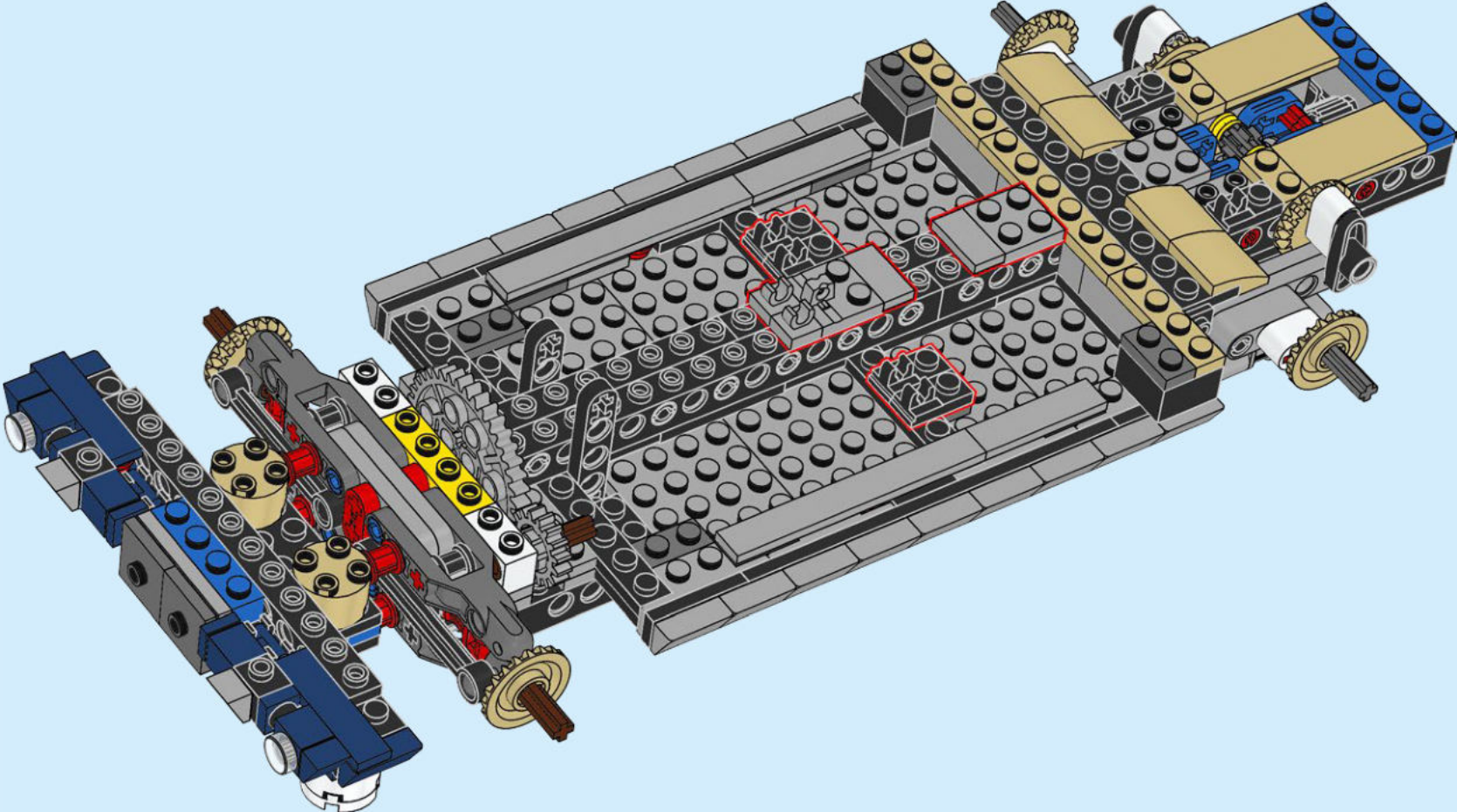

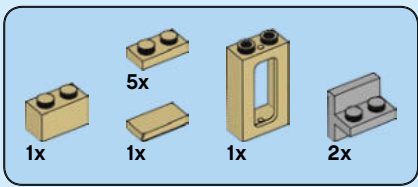

81

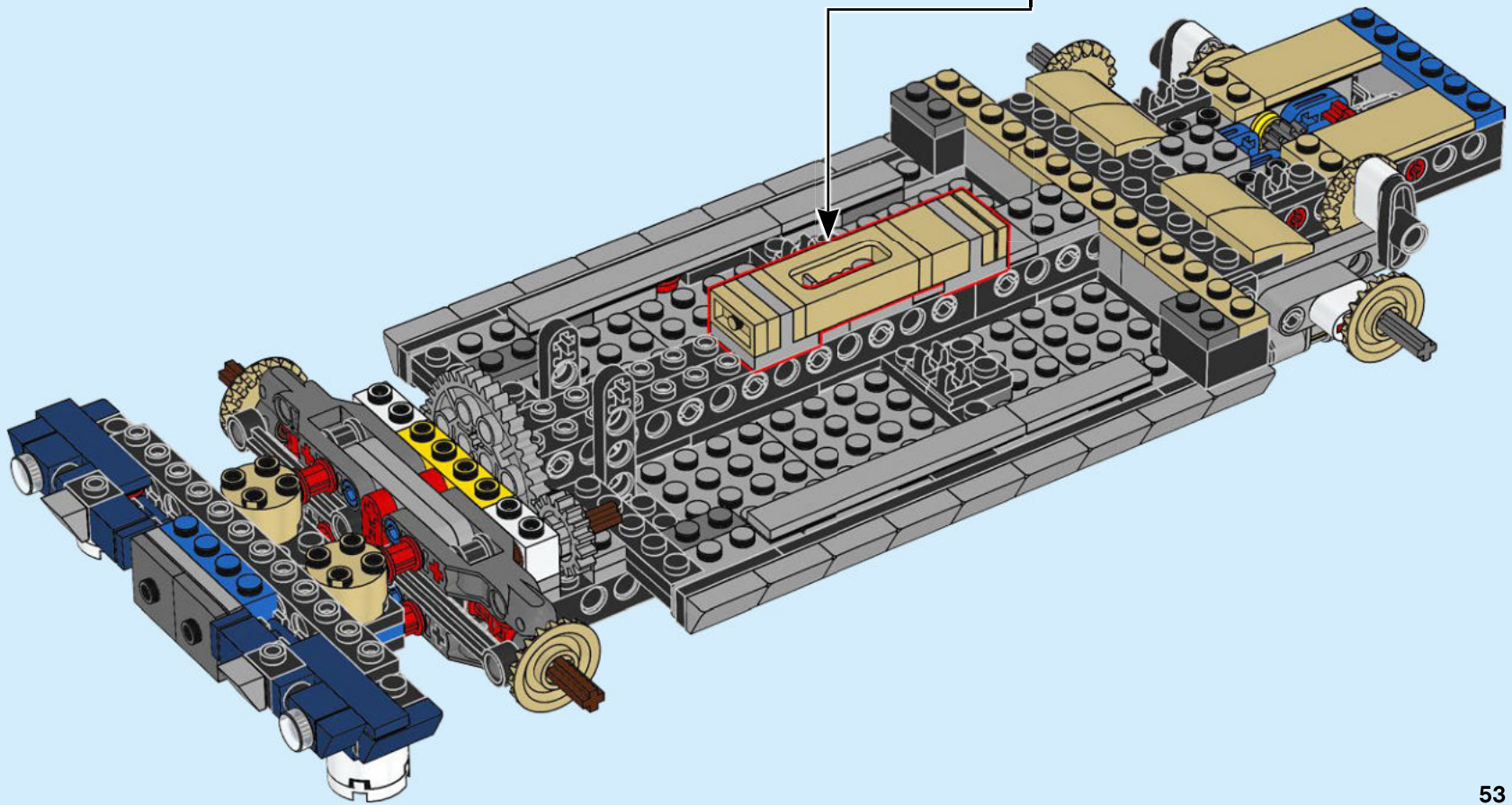
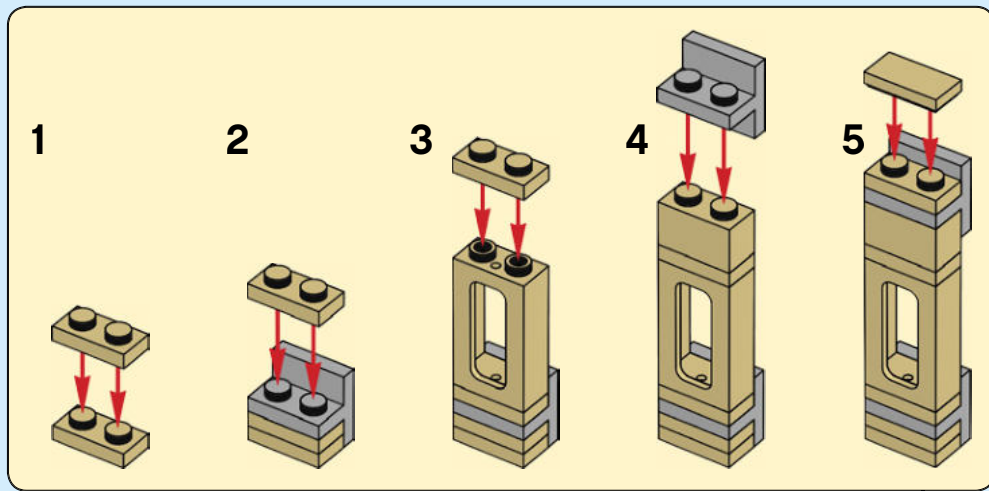

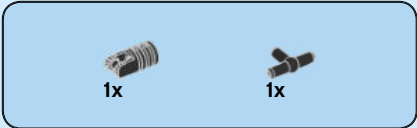

82

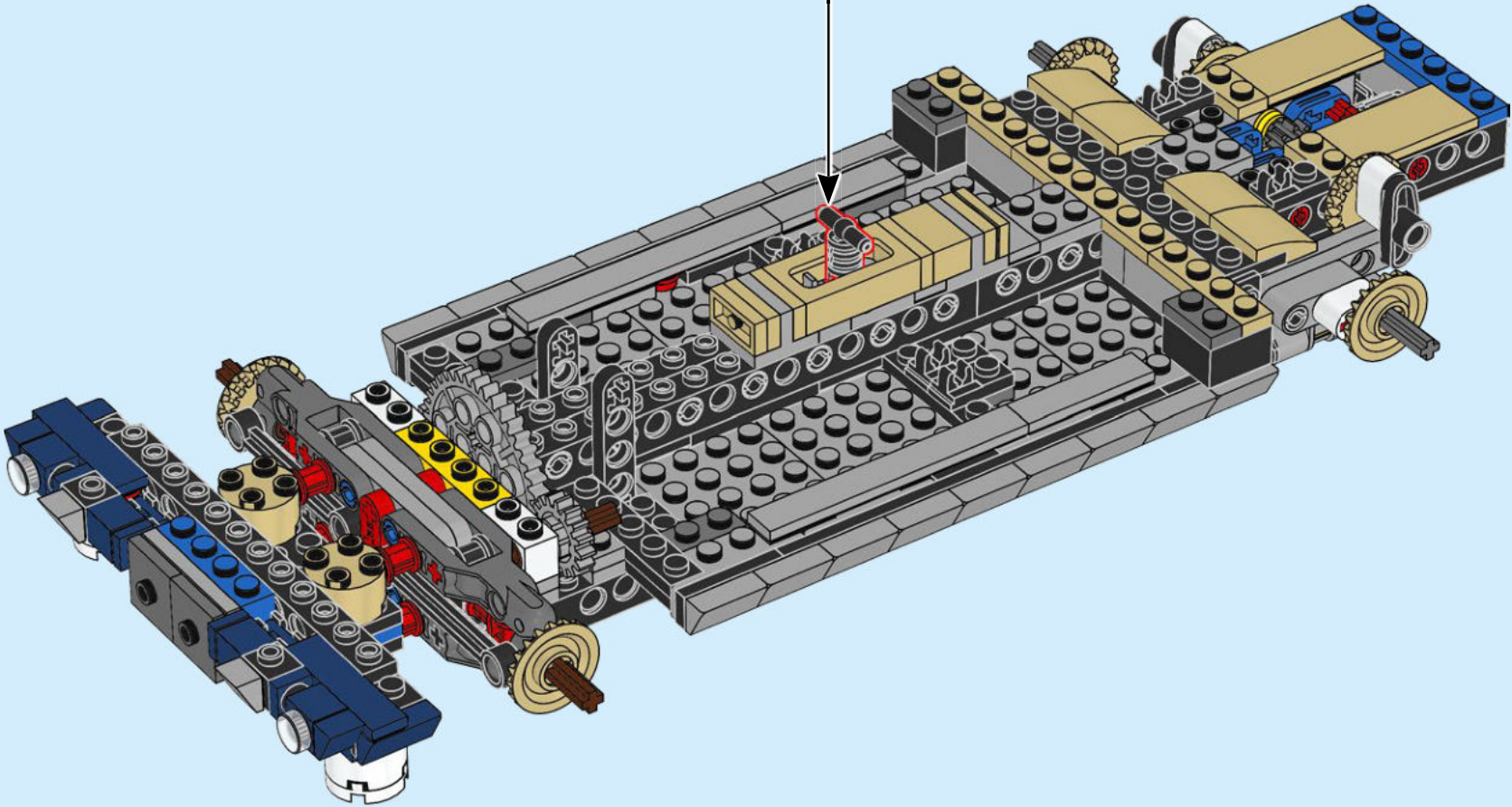

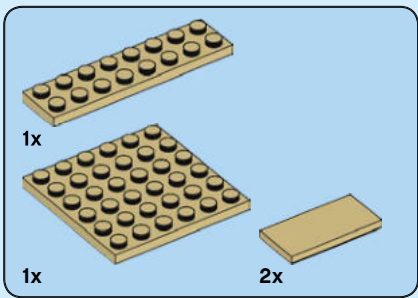

83

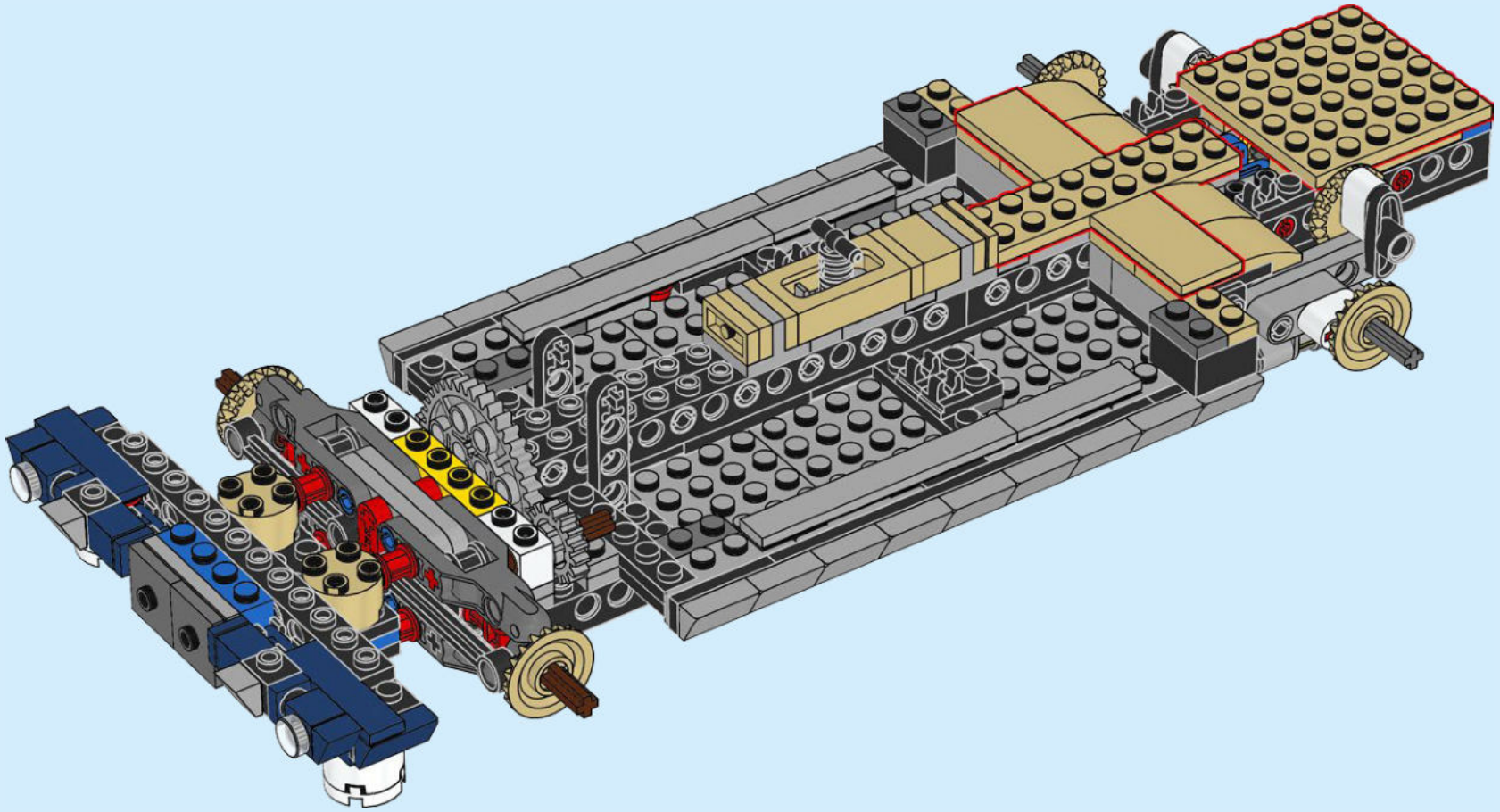

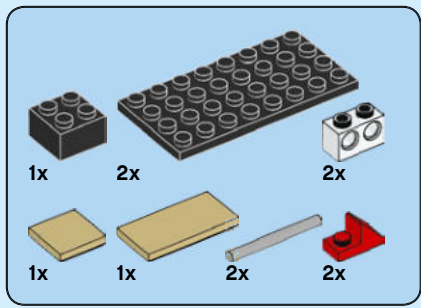

84

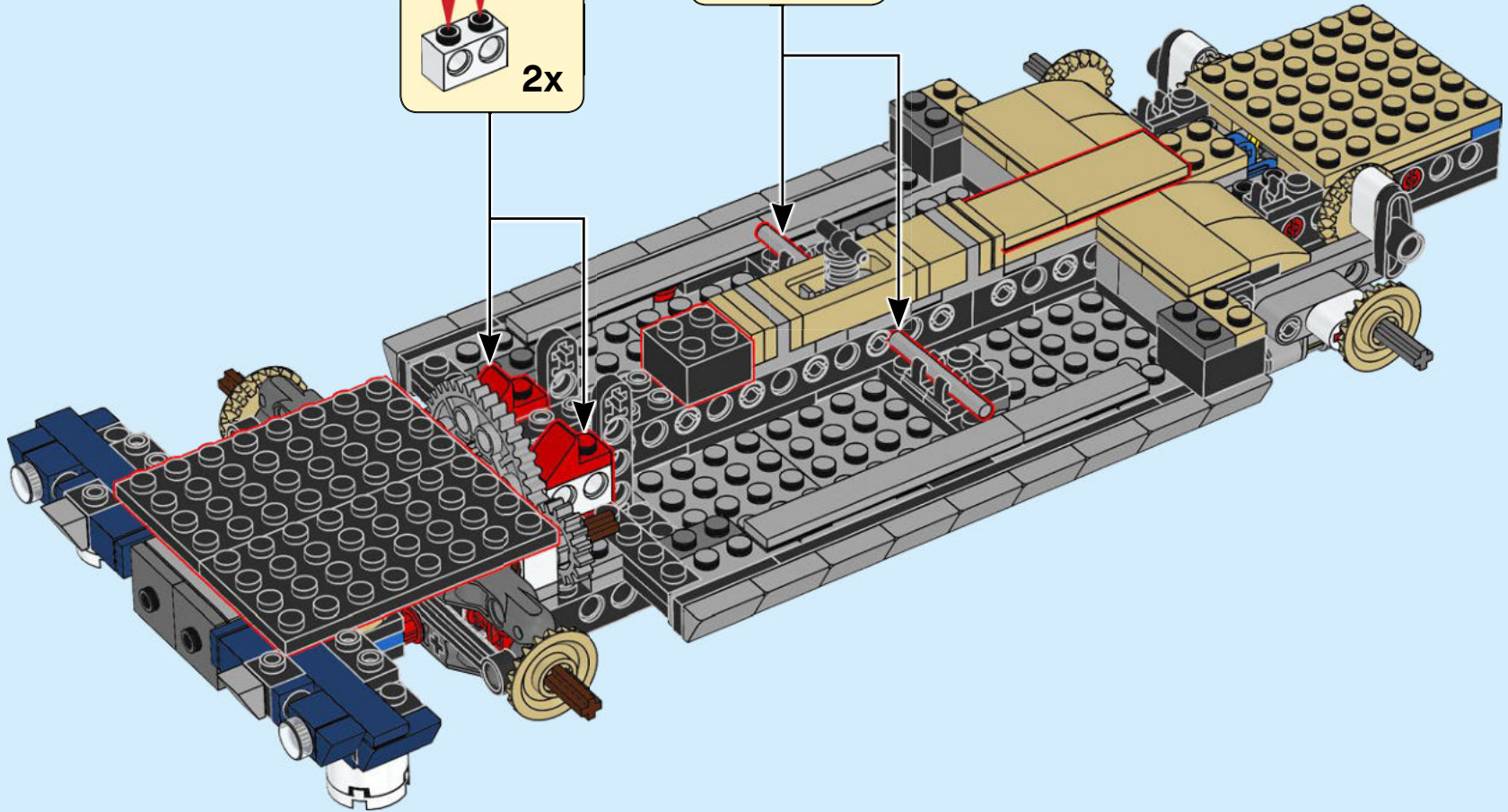
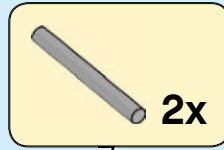
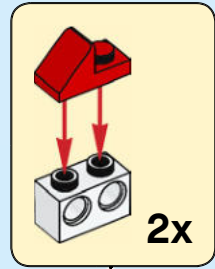

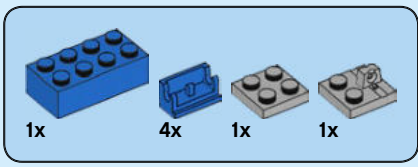

85

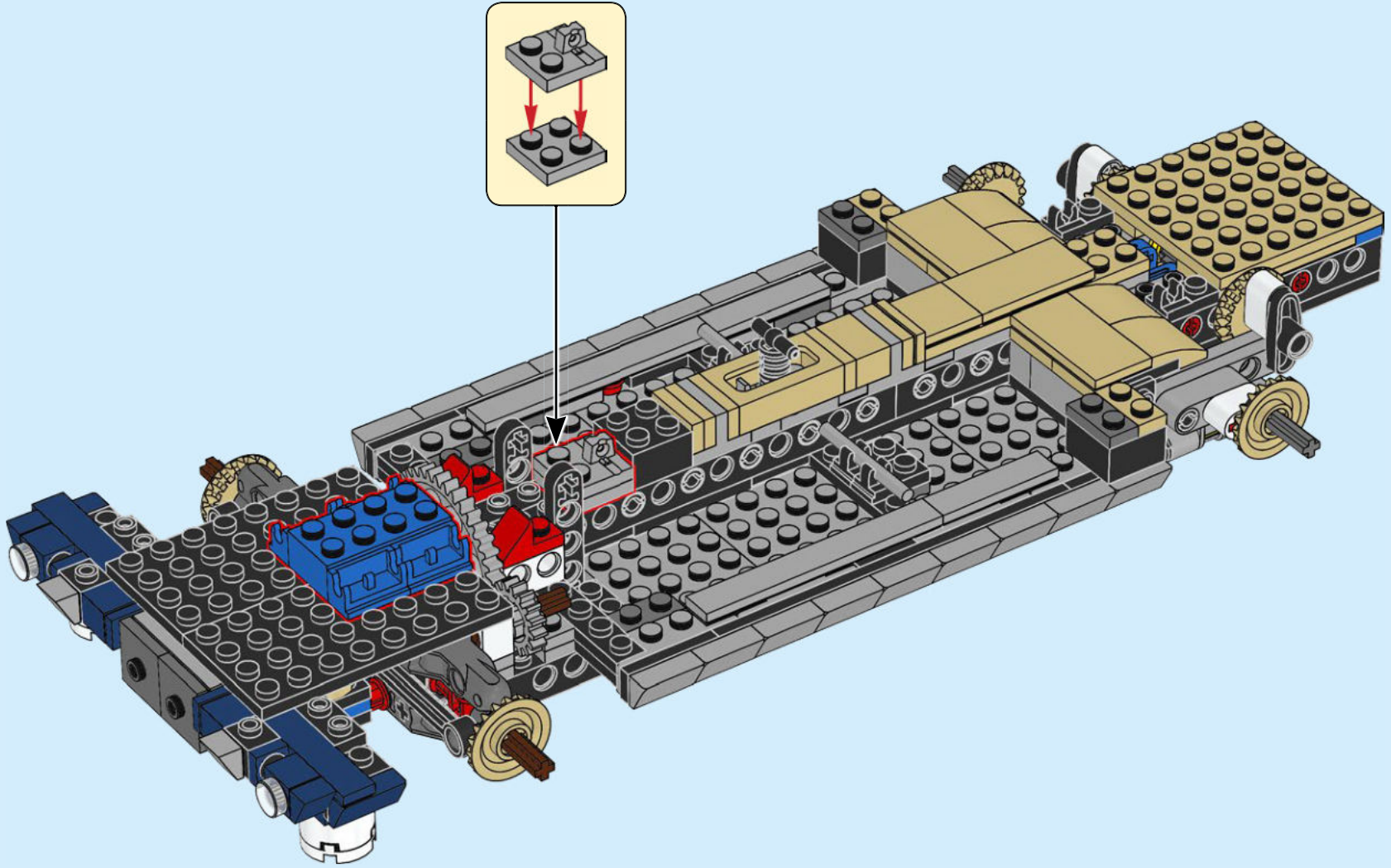

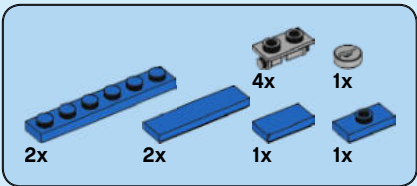

86

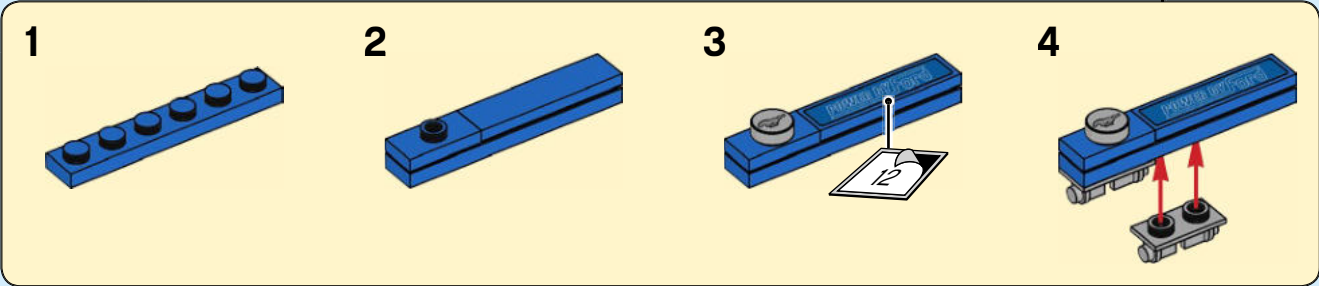
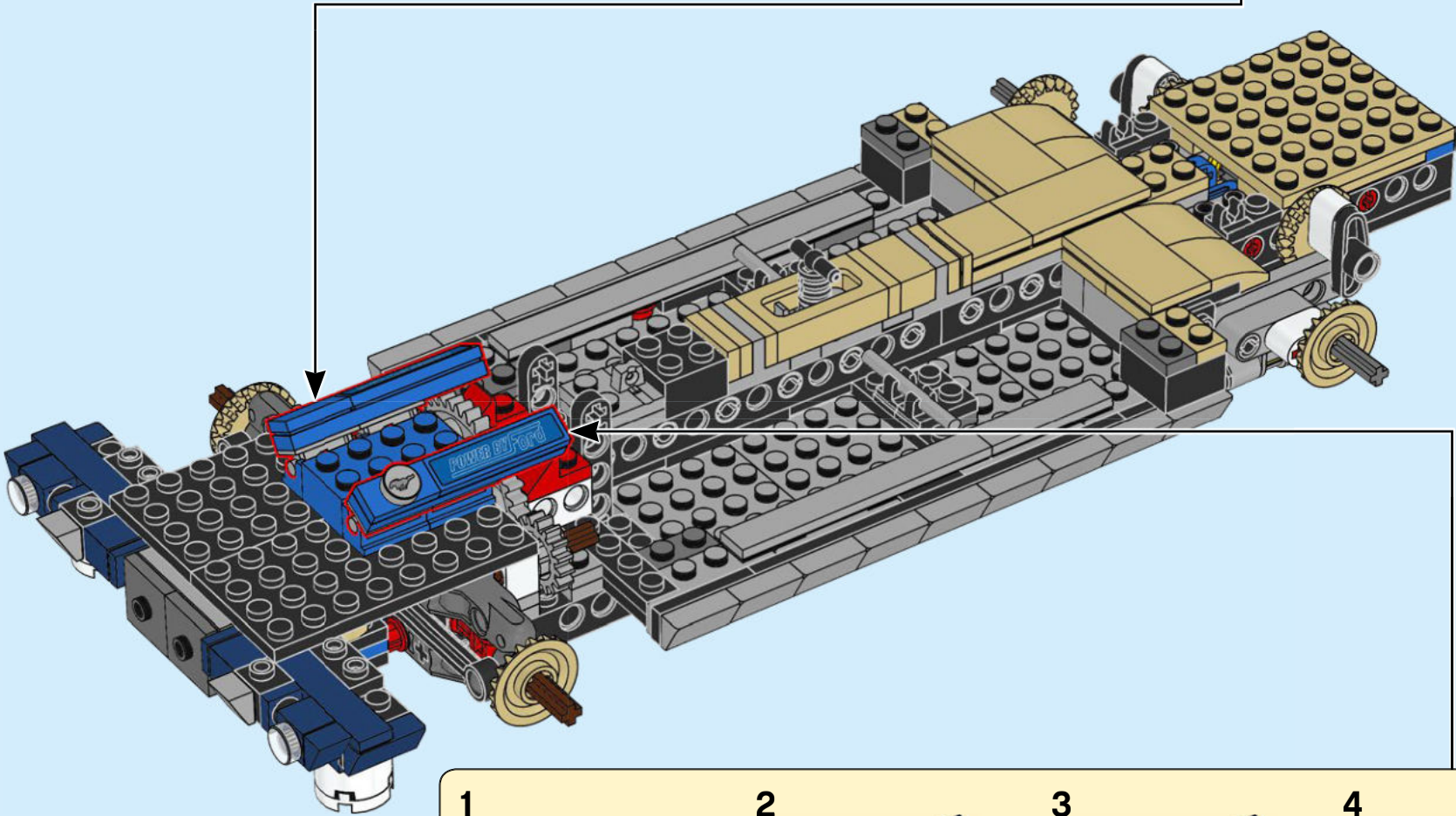
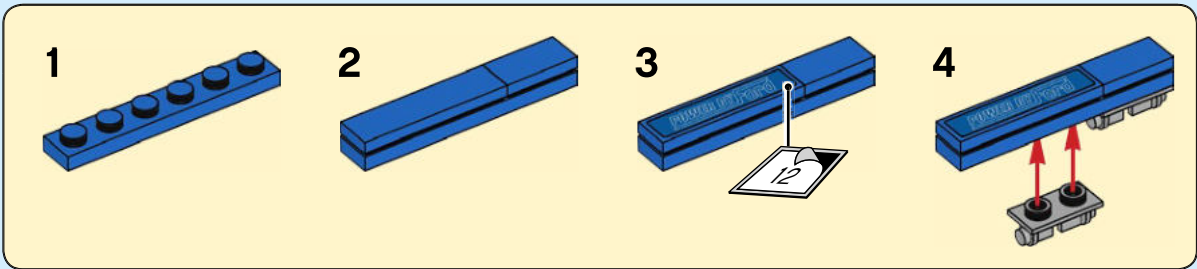



87

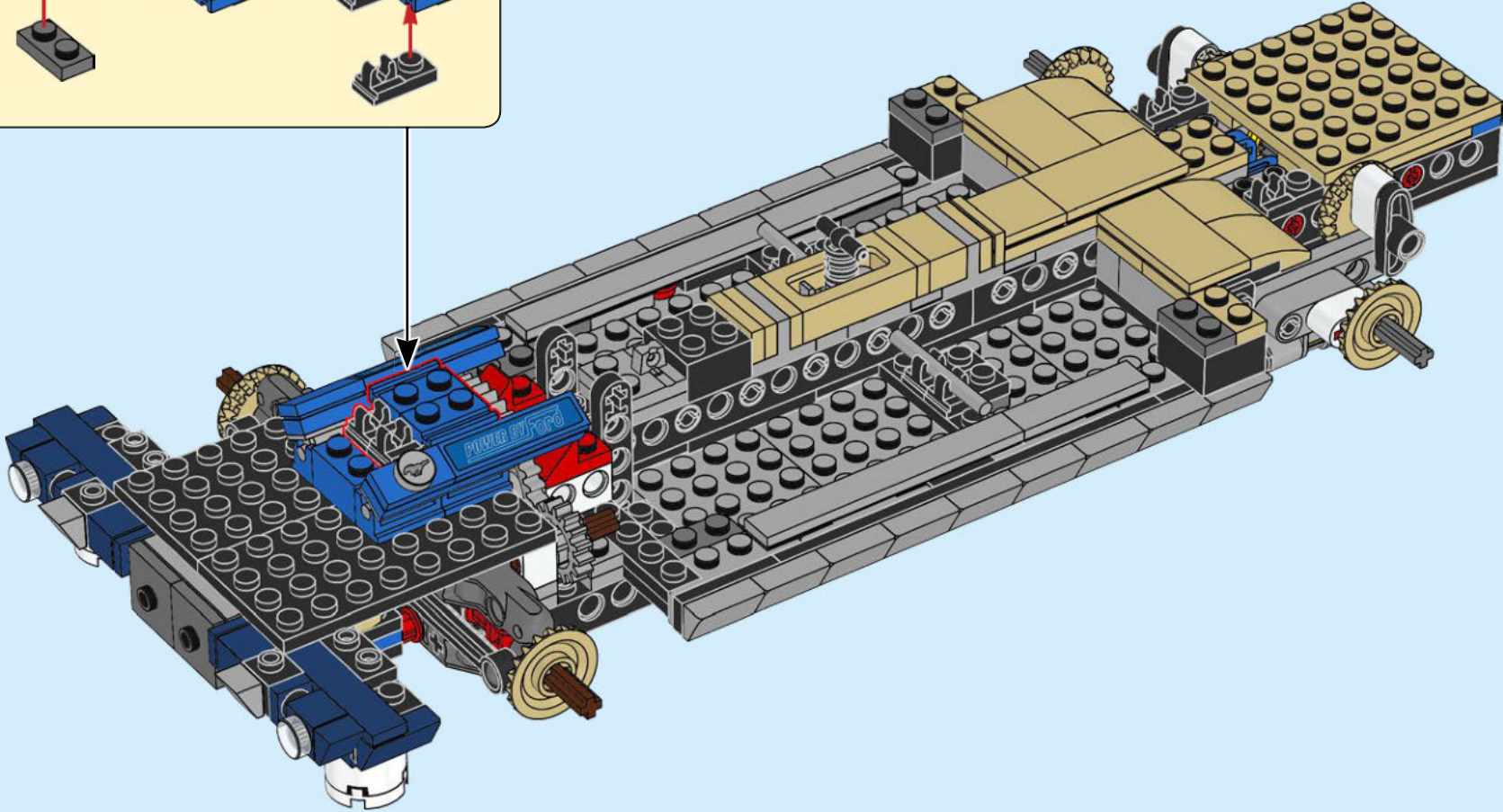
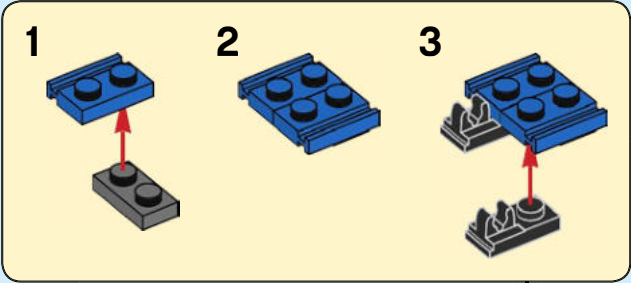

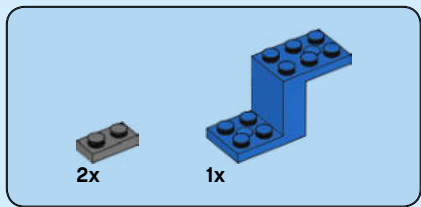

88

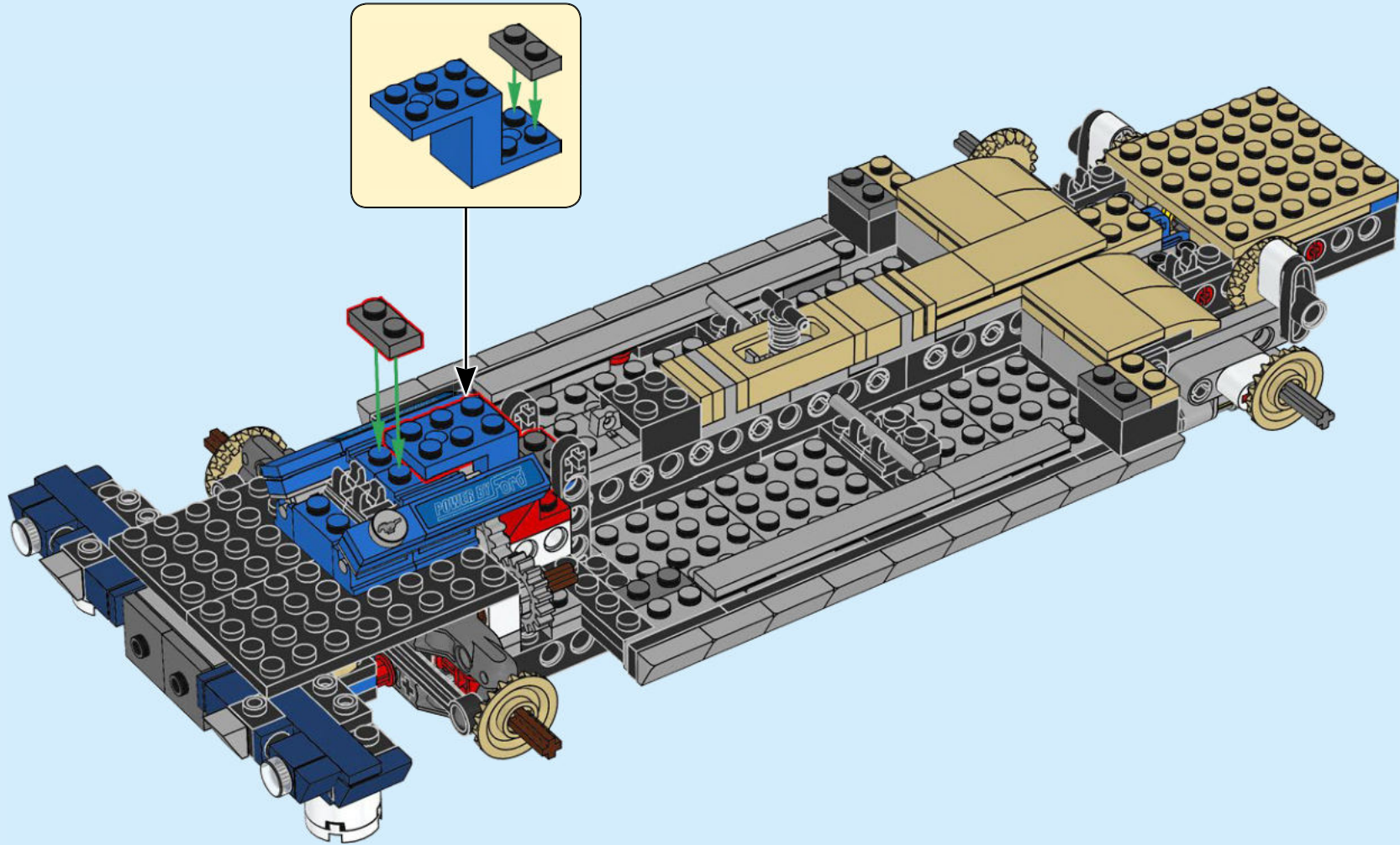

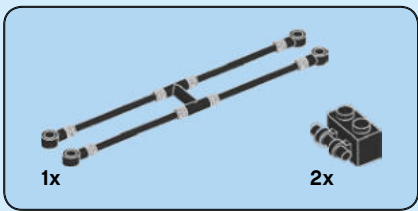

89

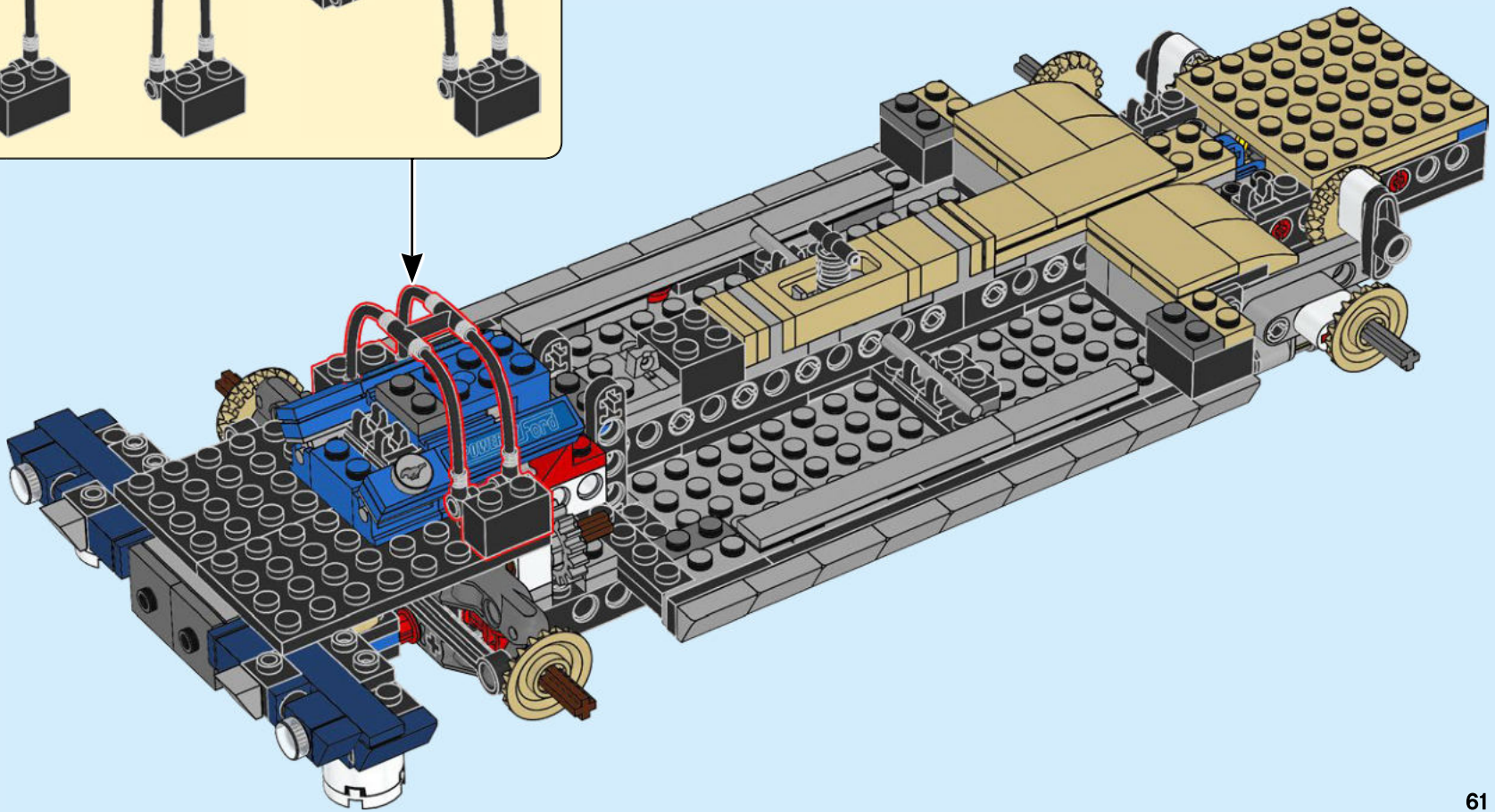
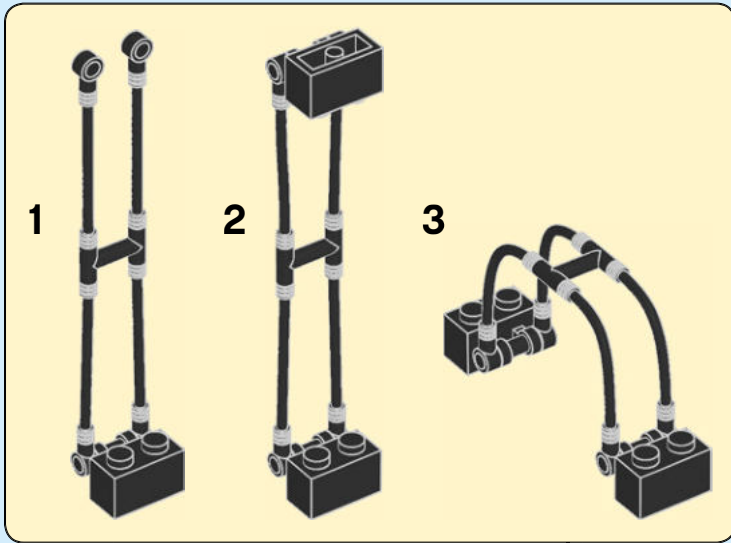



2x

90

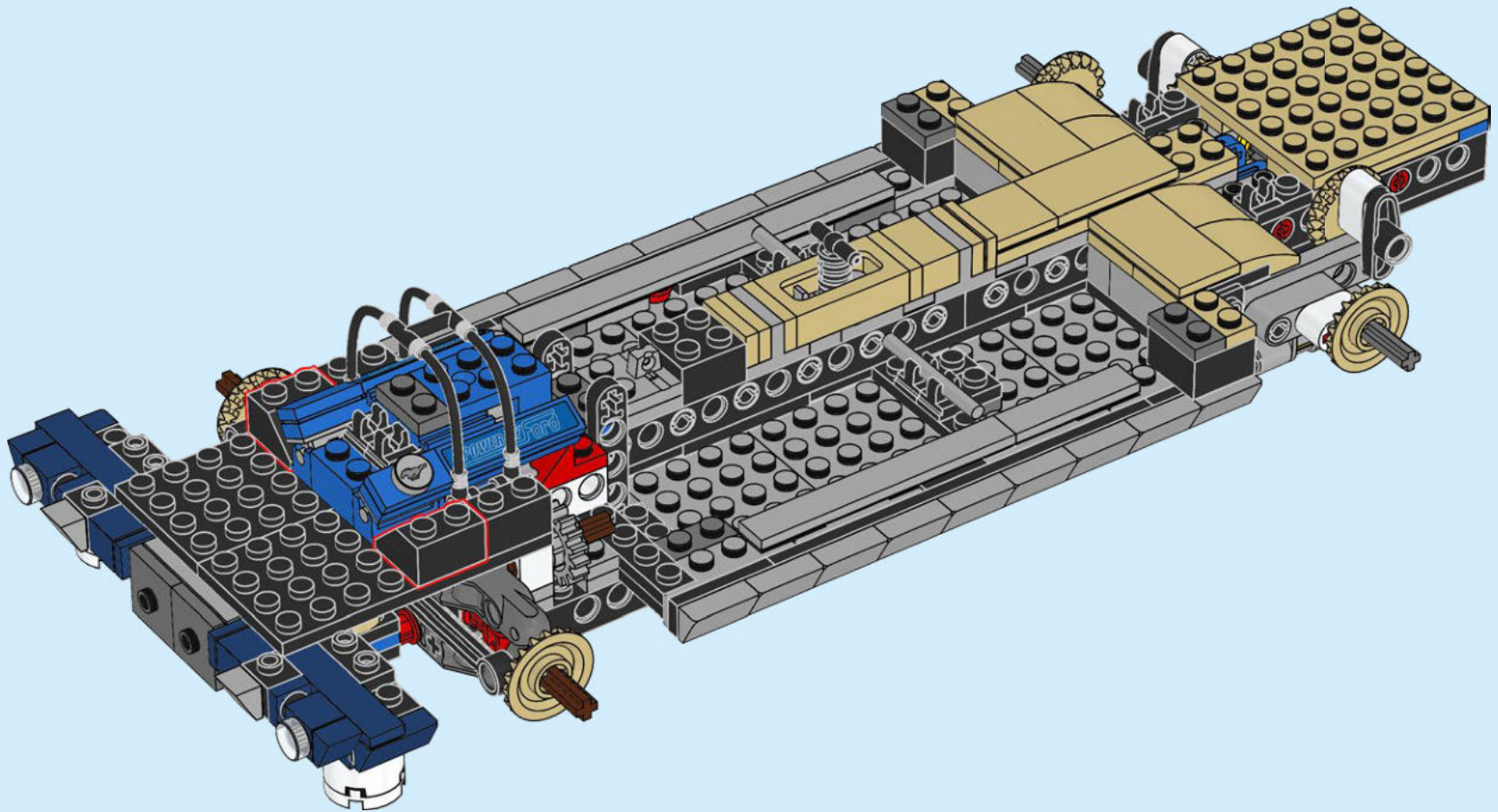

91

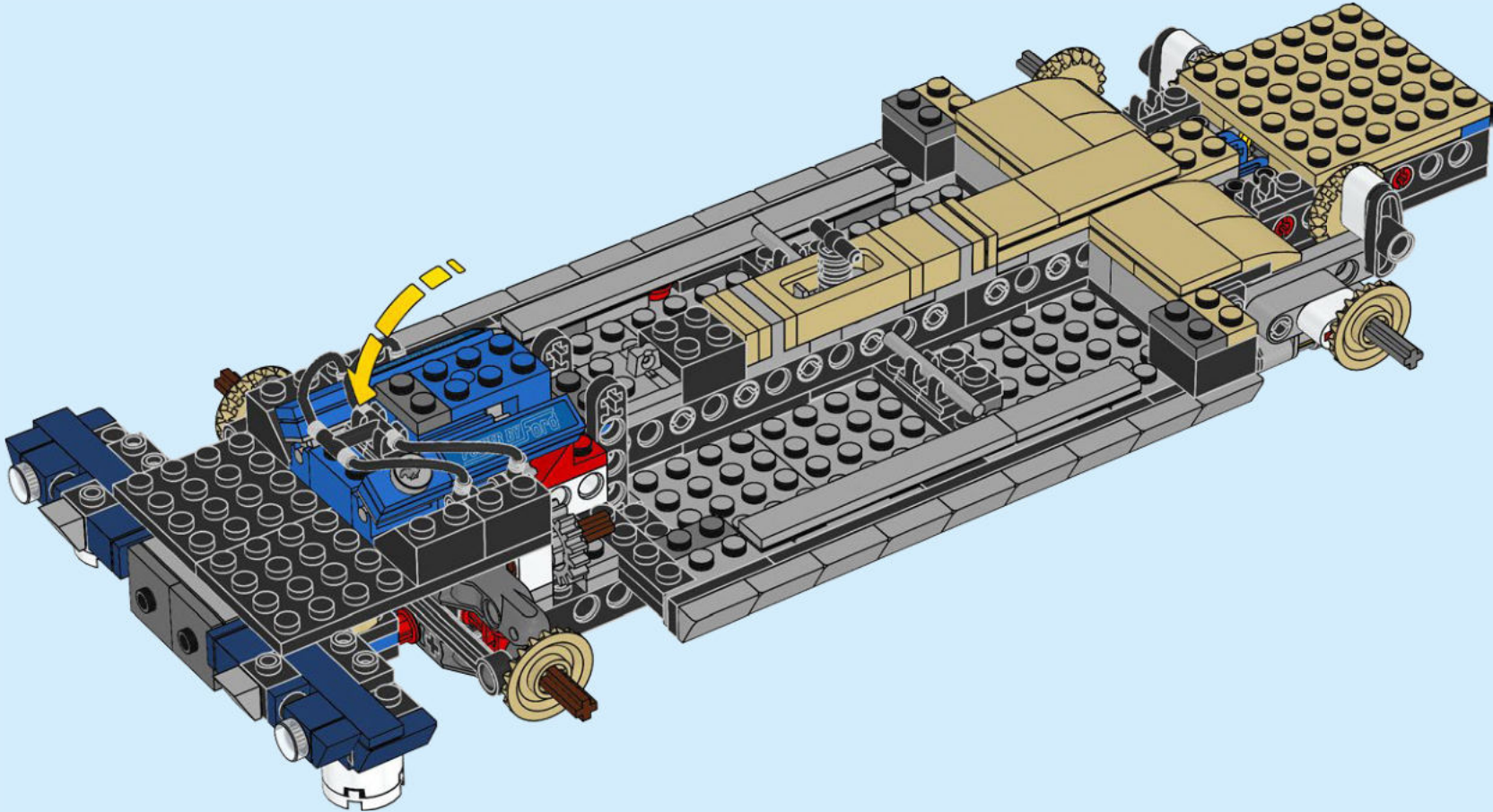

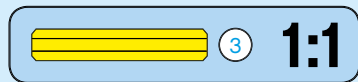
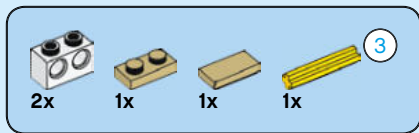

92

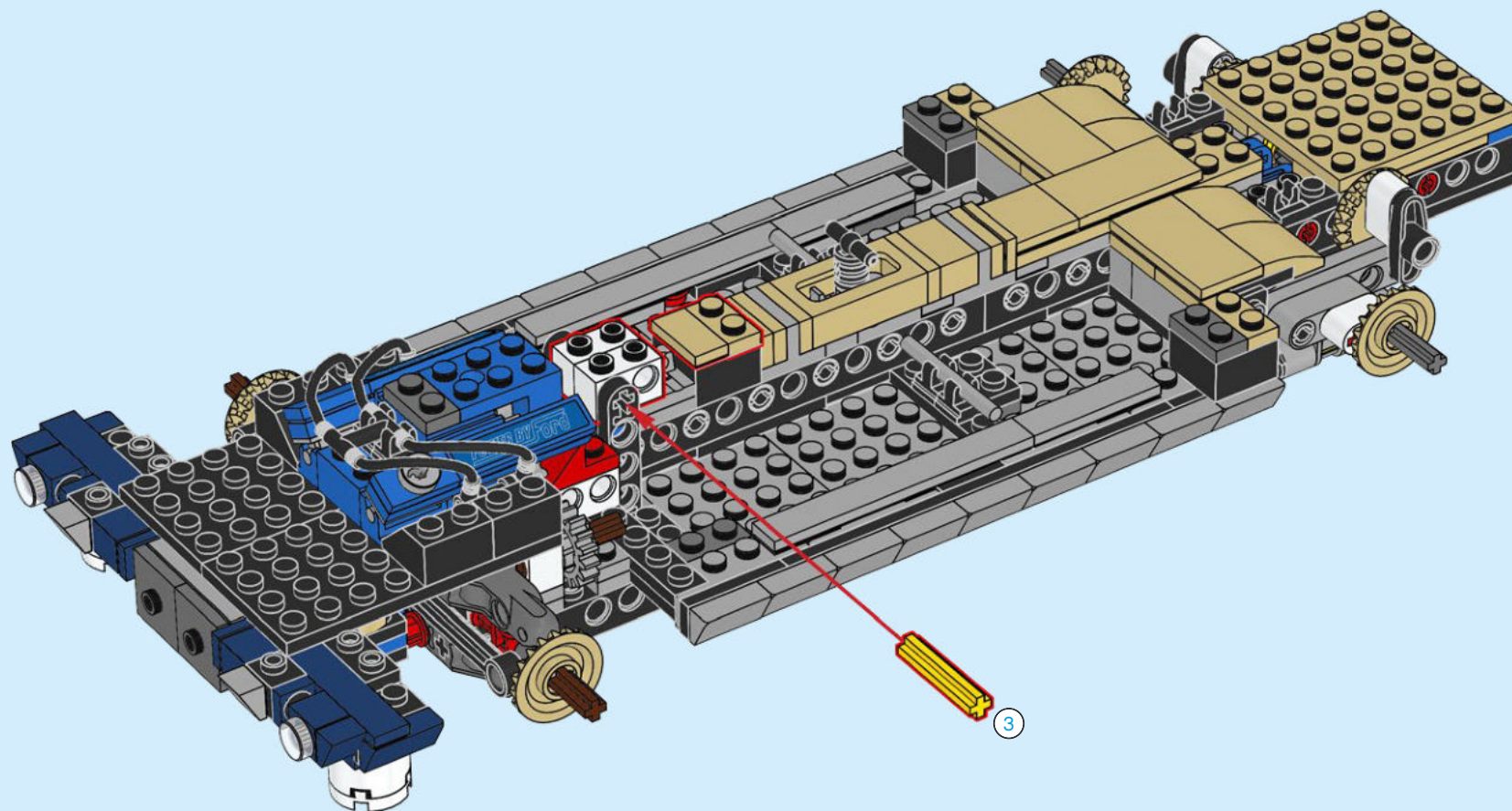

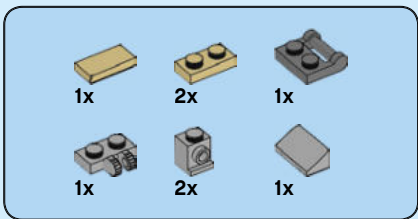

93

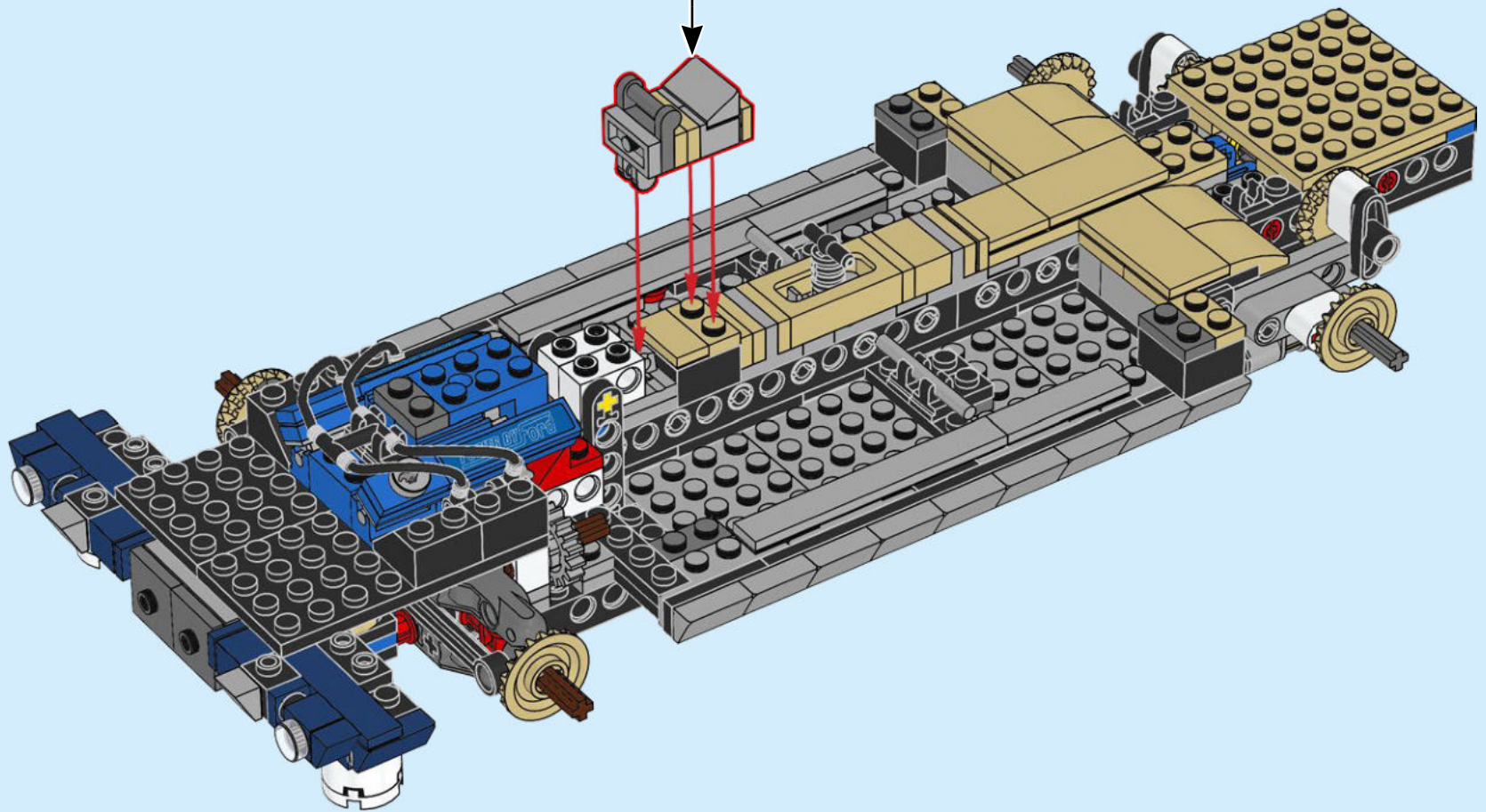
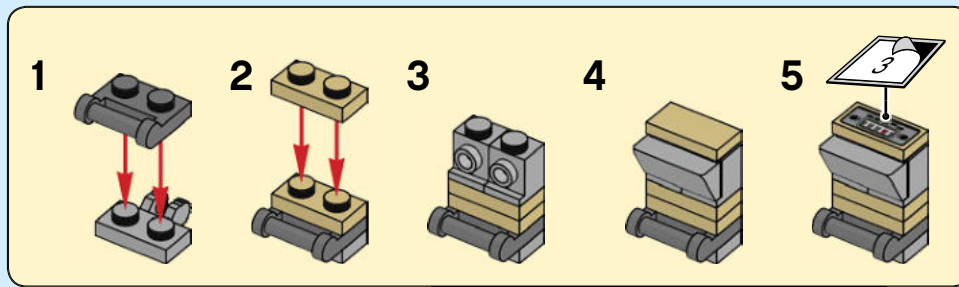

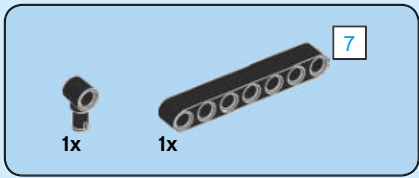

94

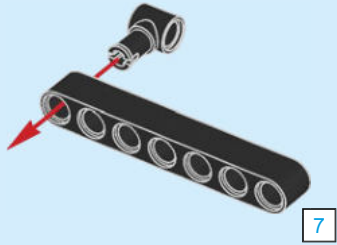

95

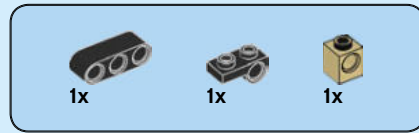
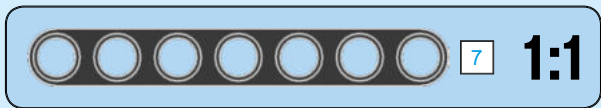
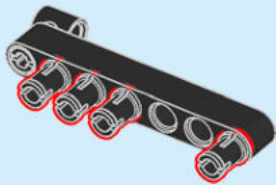

96

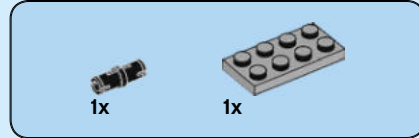
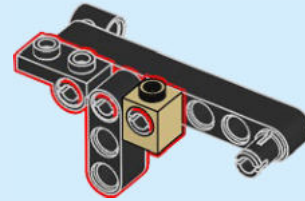

97

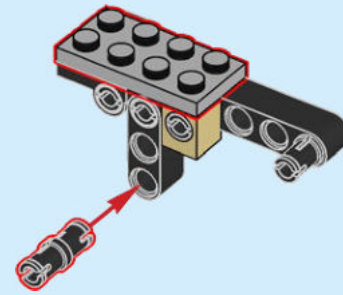

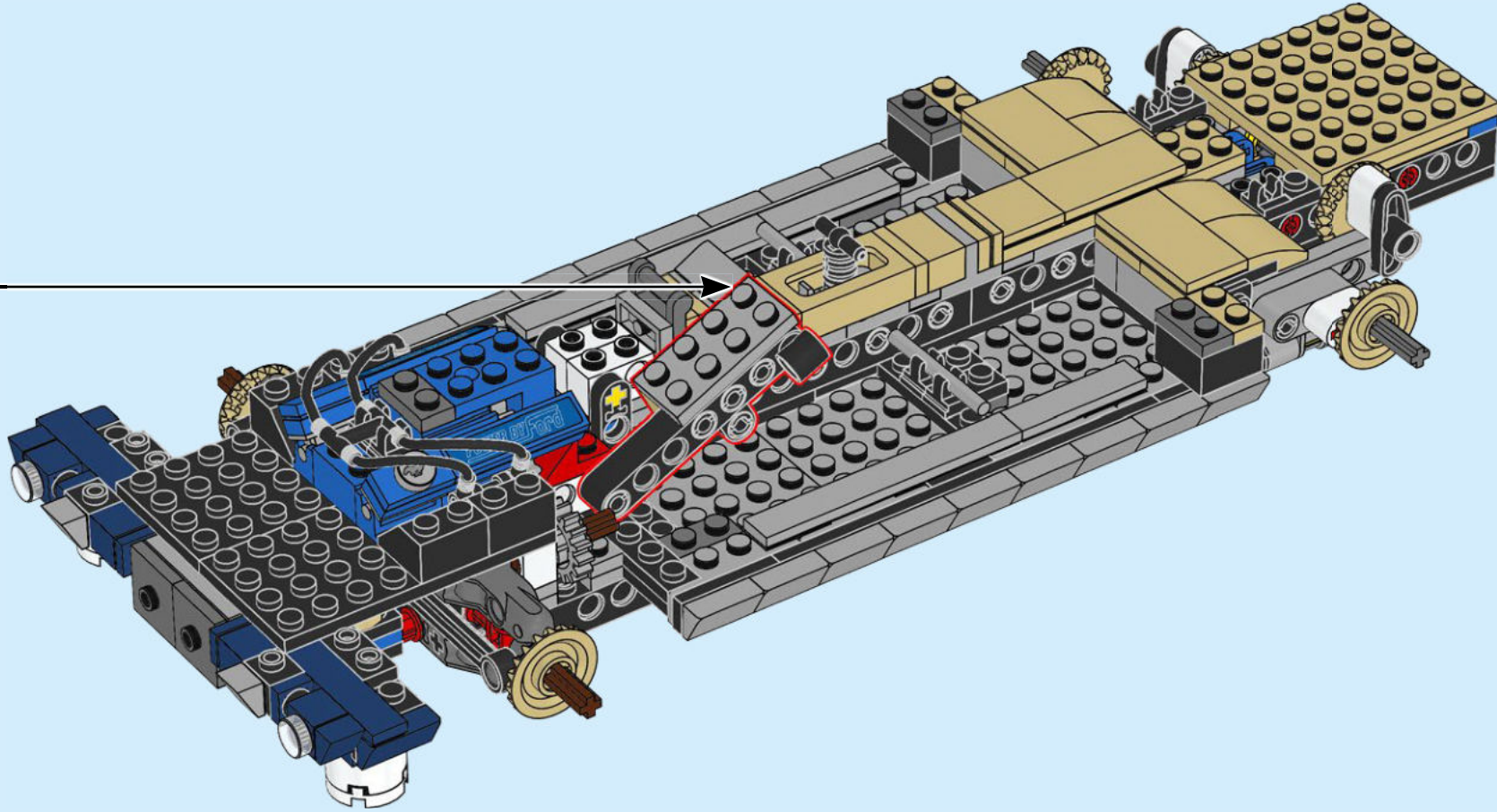

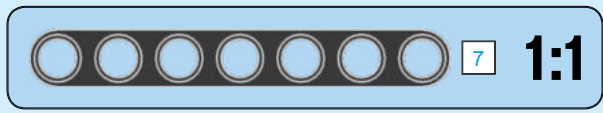
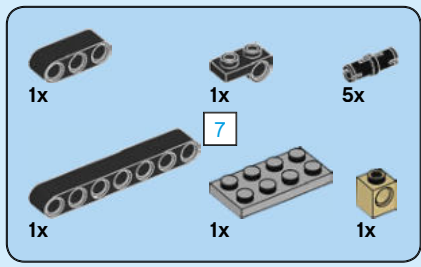

99

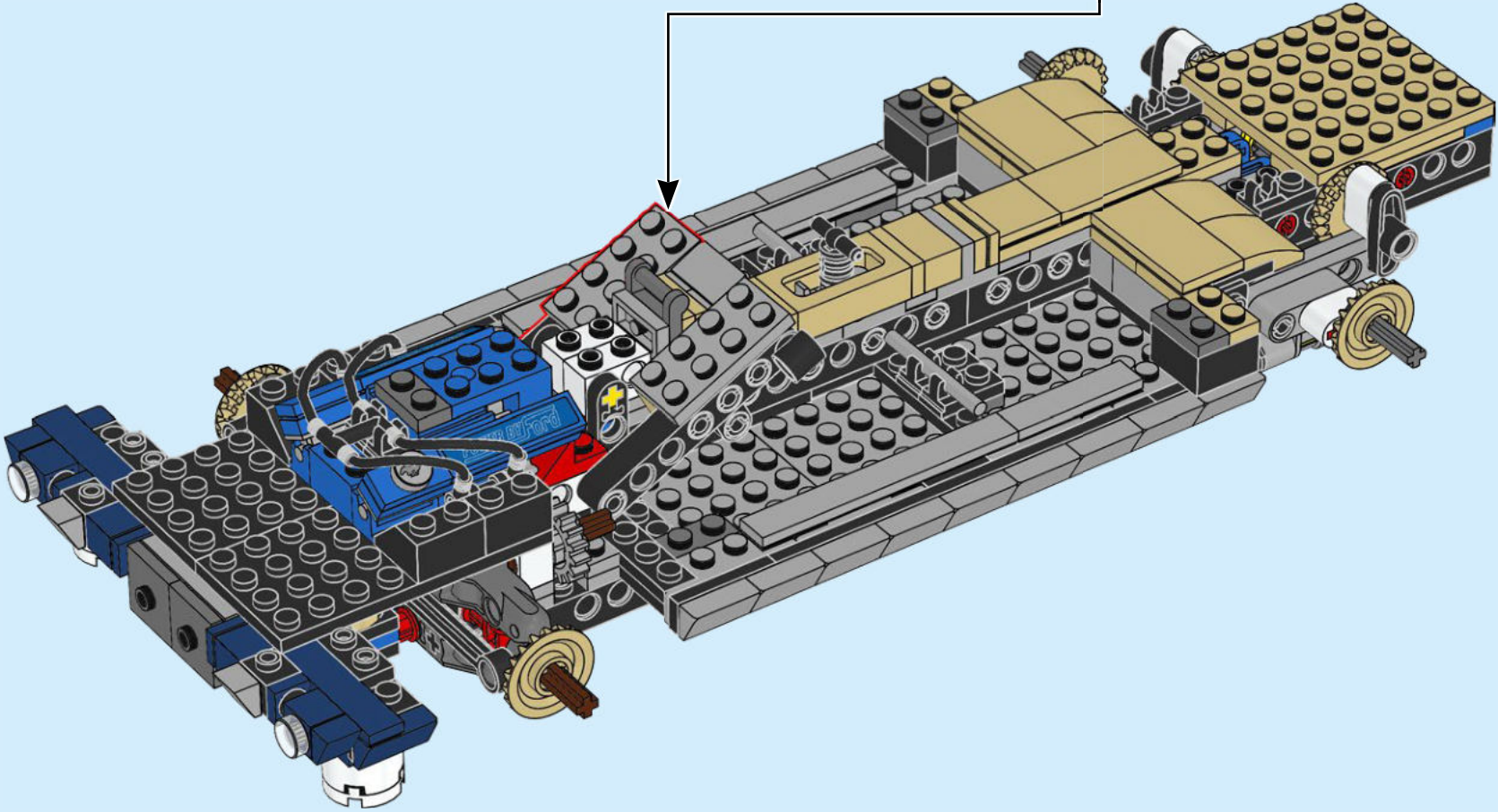
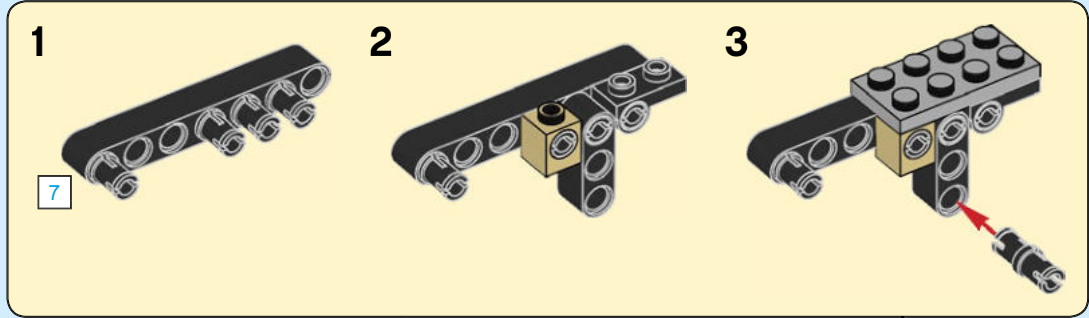

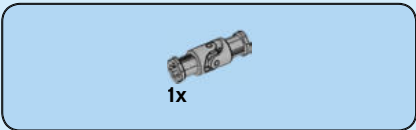

100

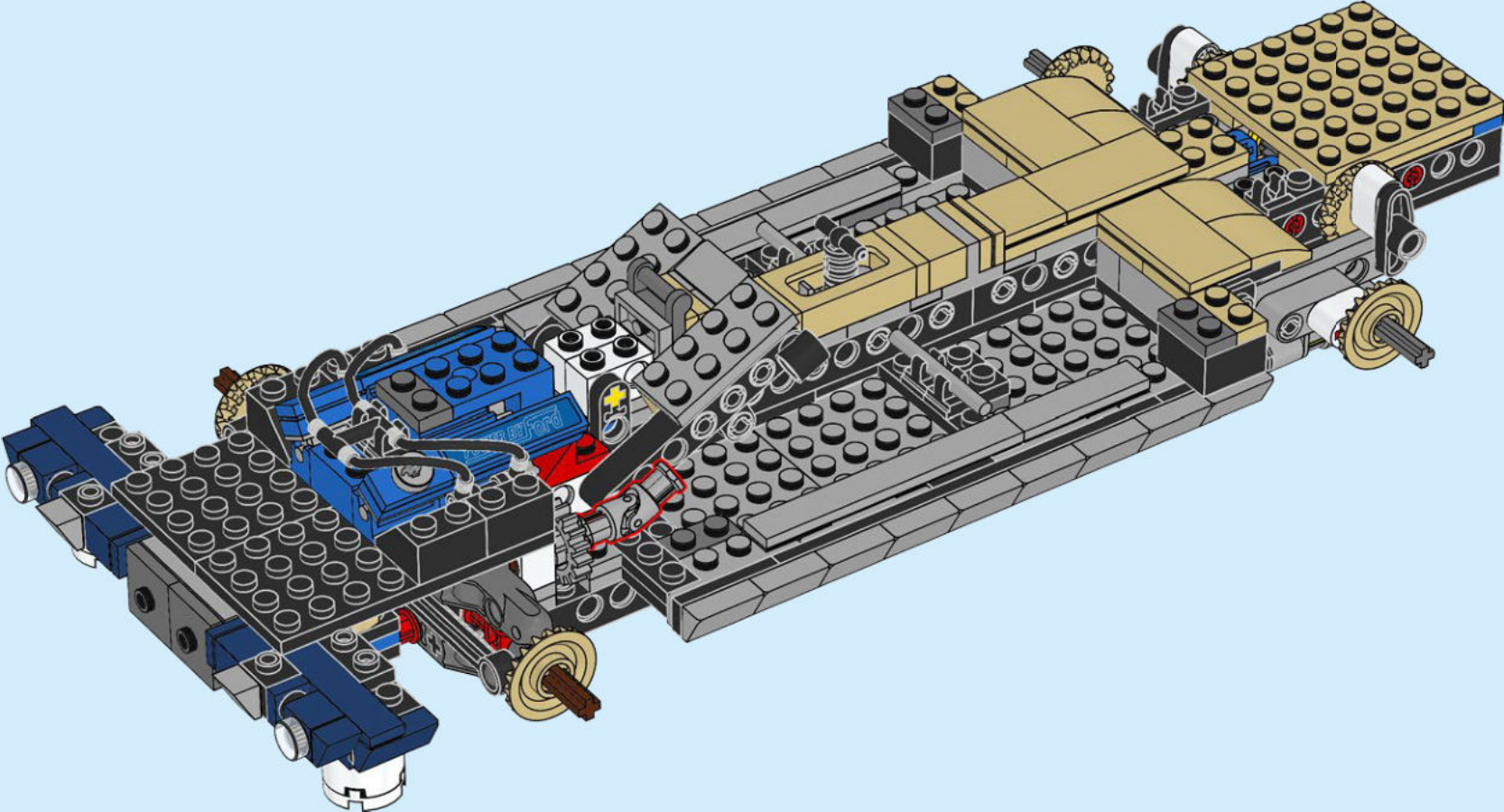

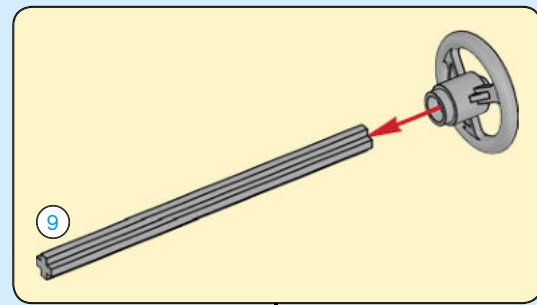
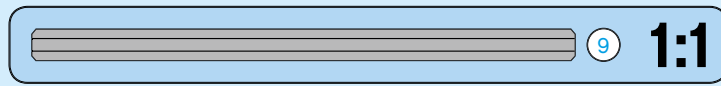
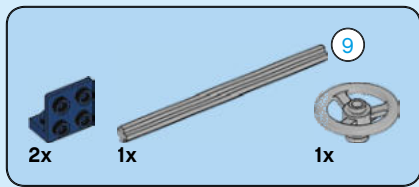

101

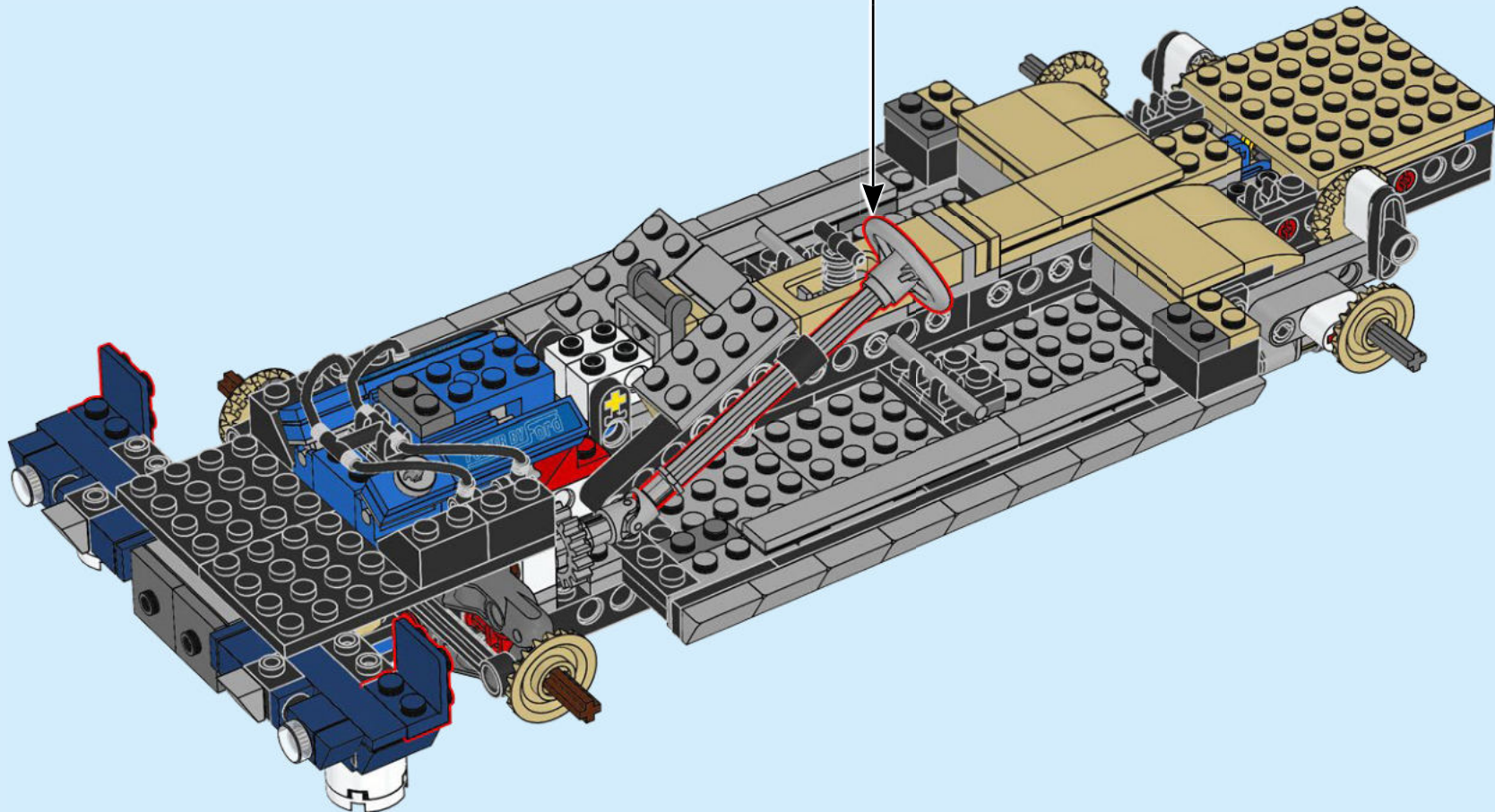

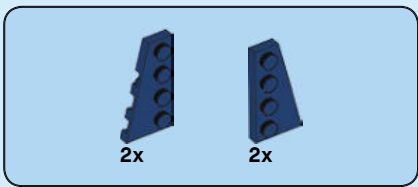

102

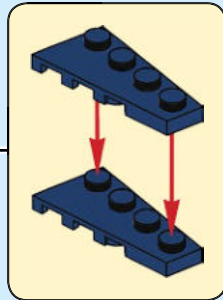
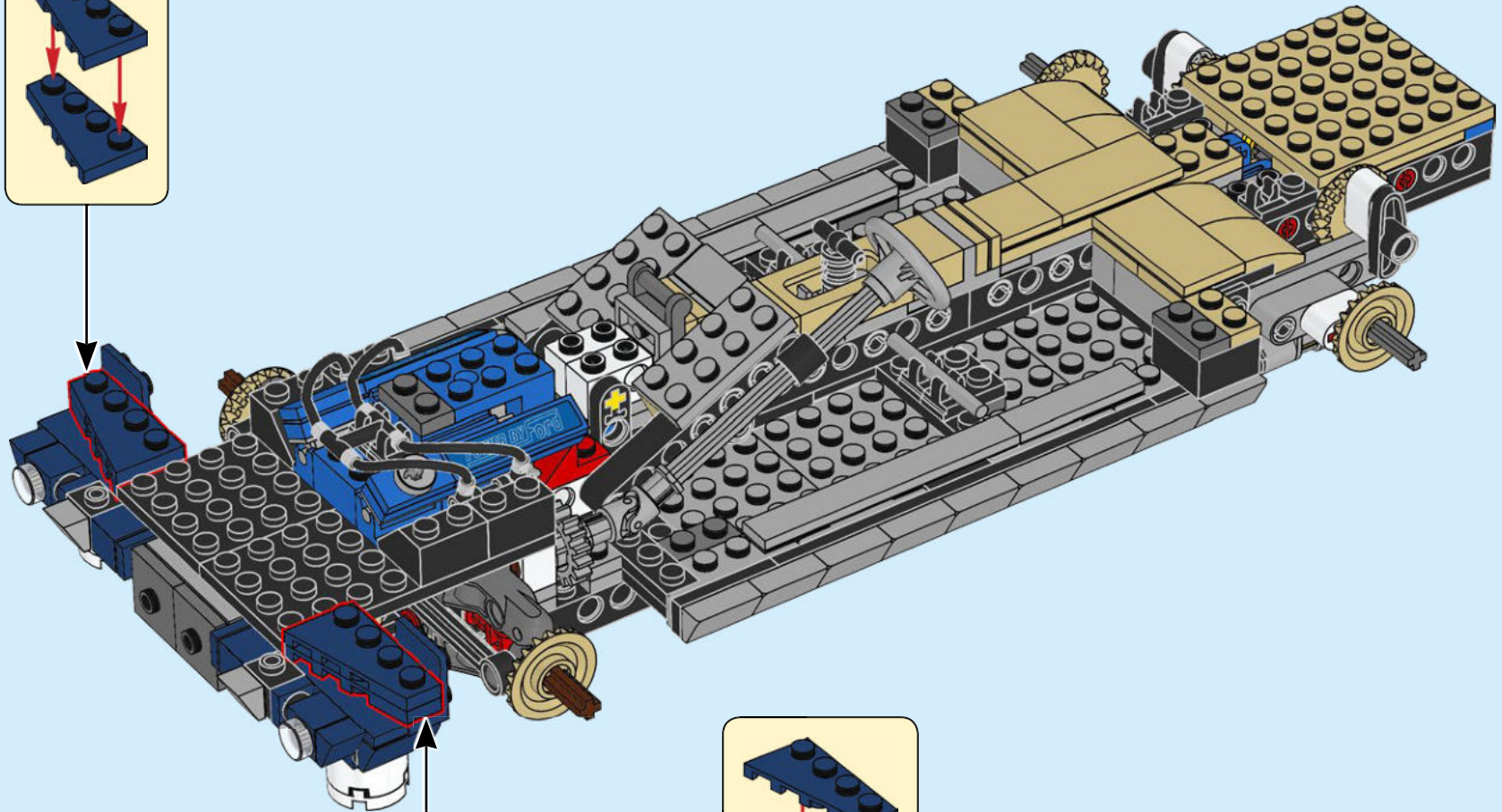
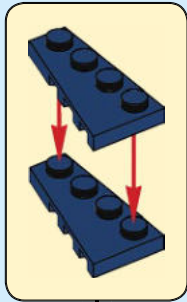

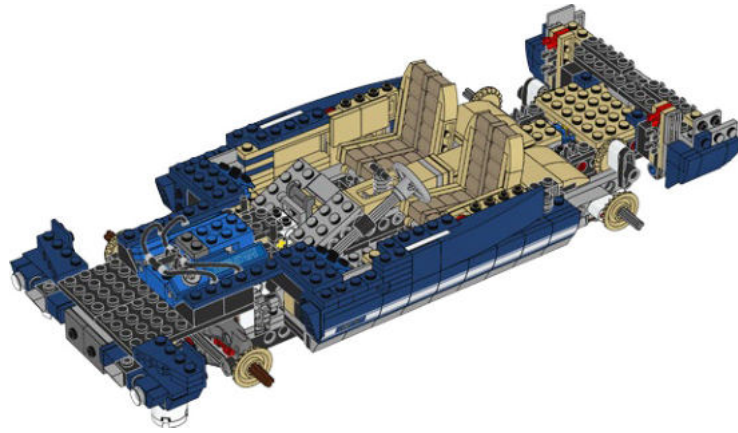
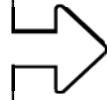
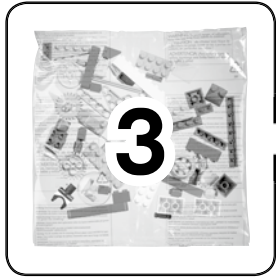

1x



2x

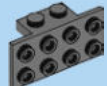

2x

103

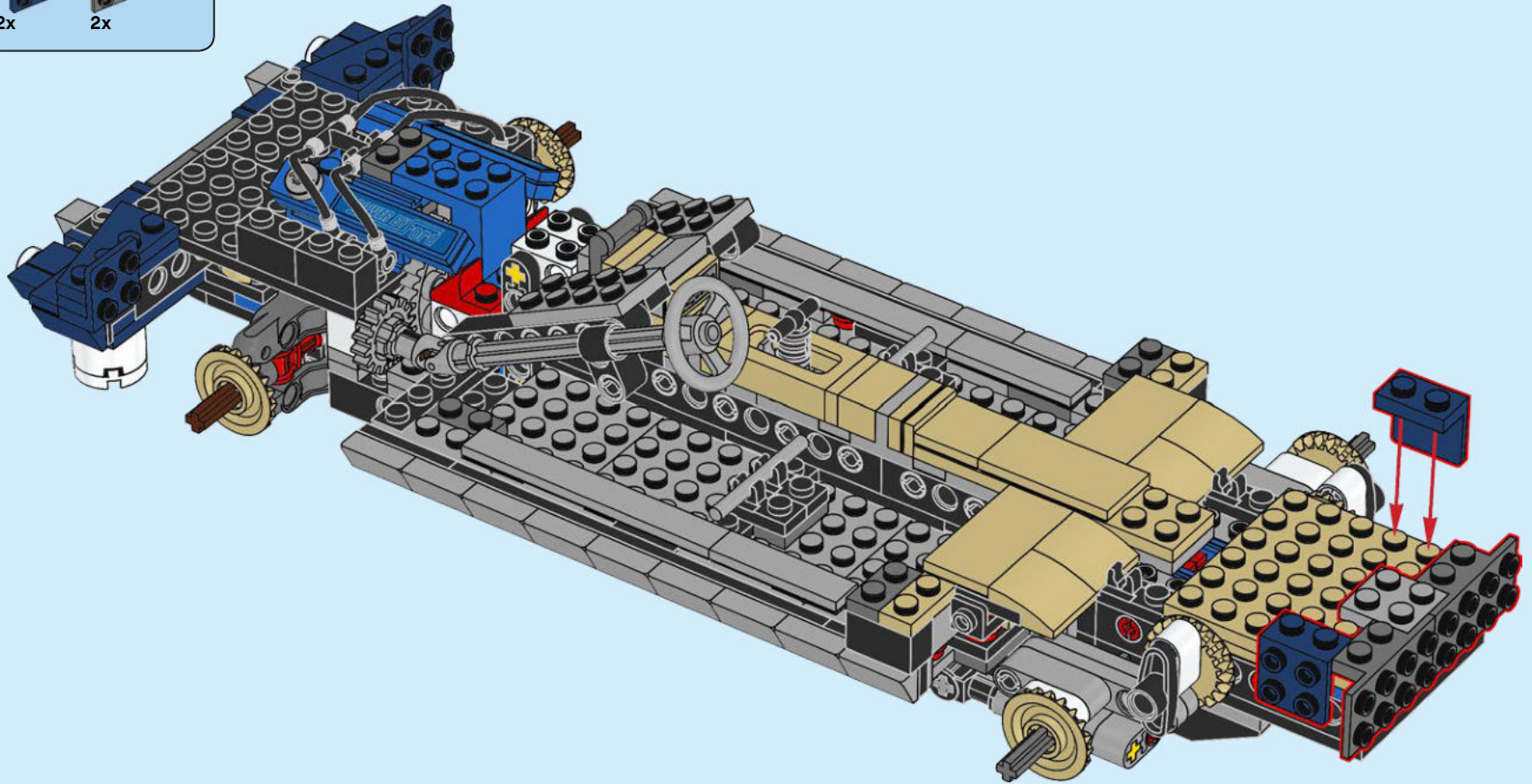

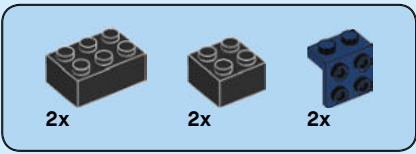

104

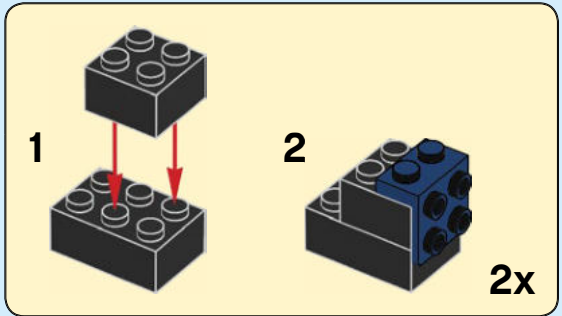
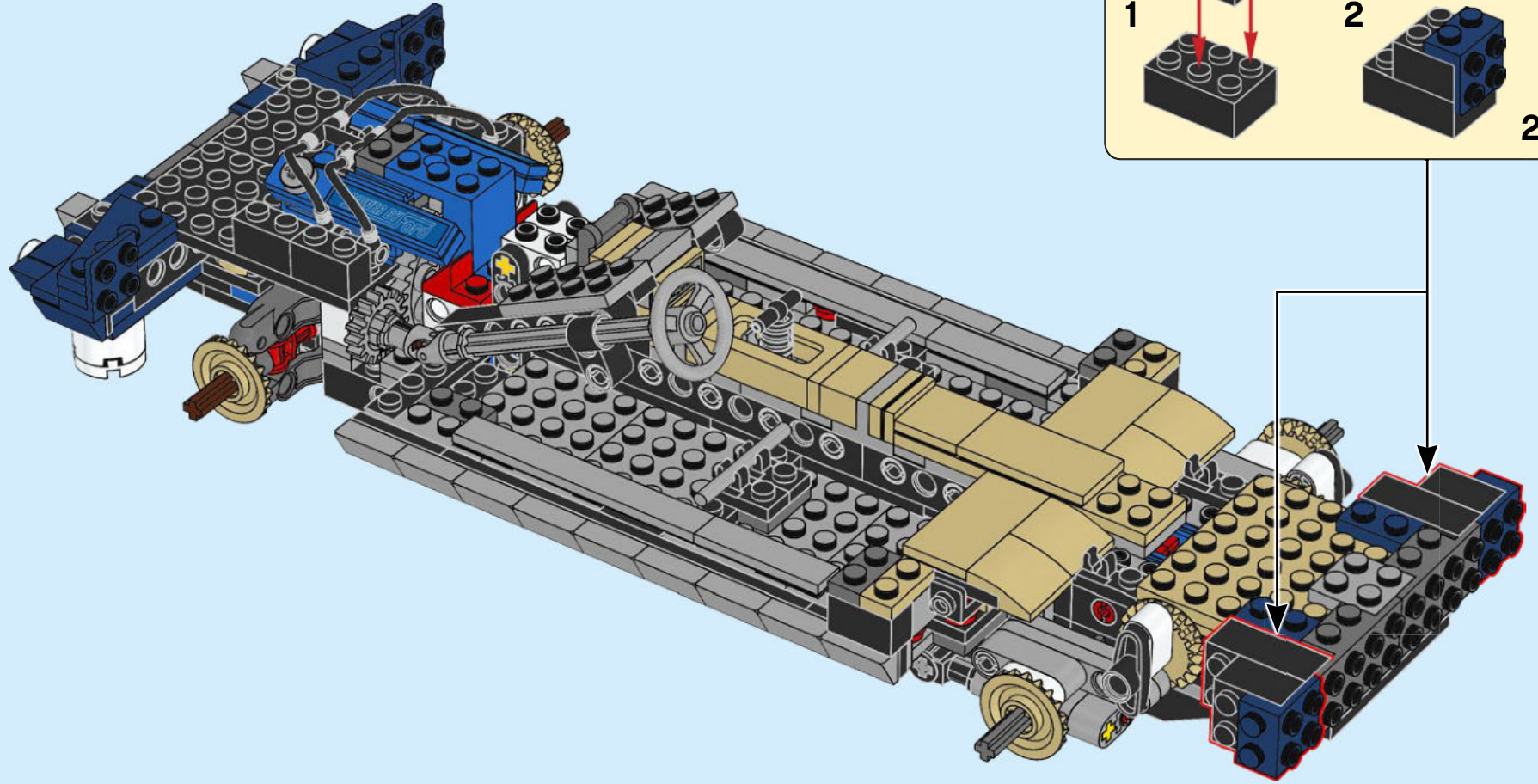

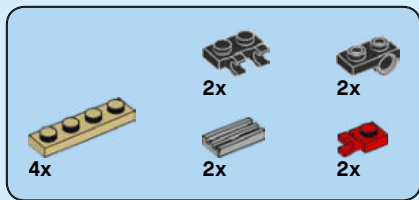

105

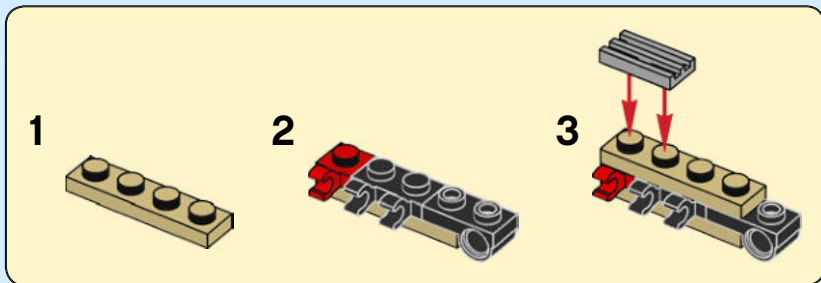
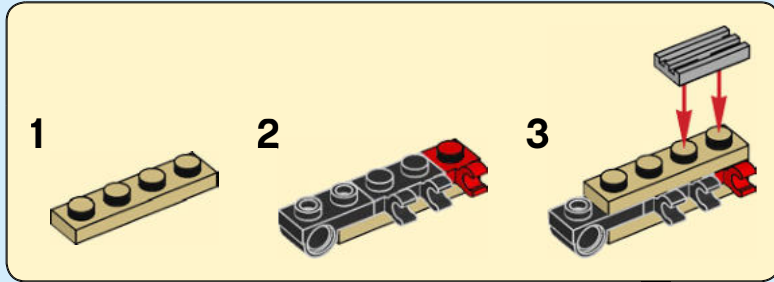
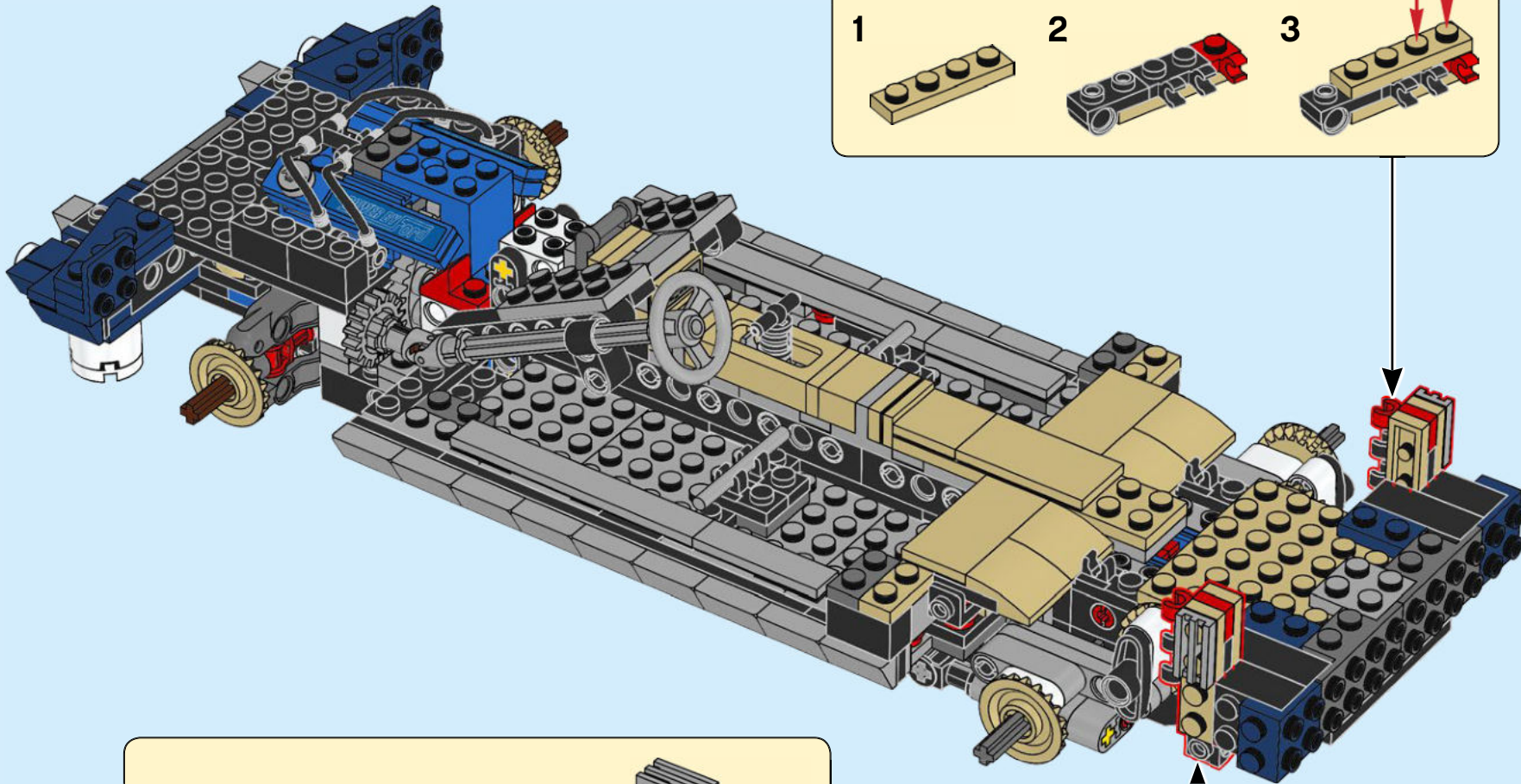

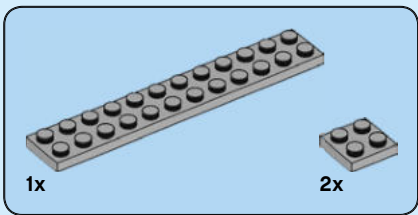

106

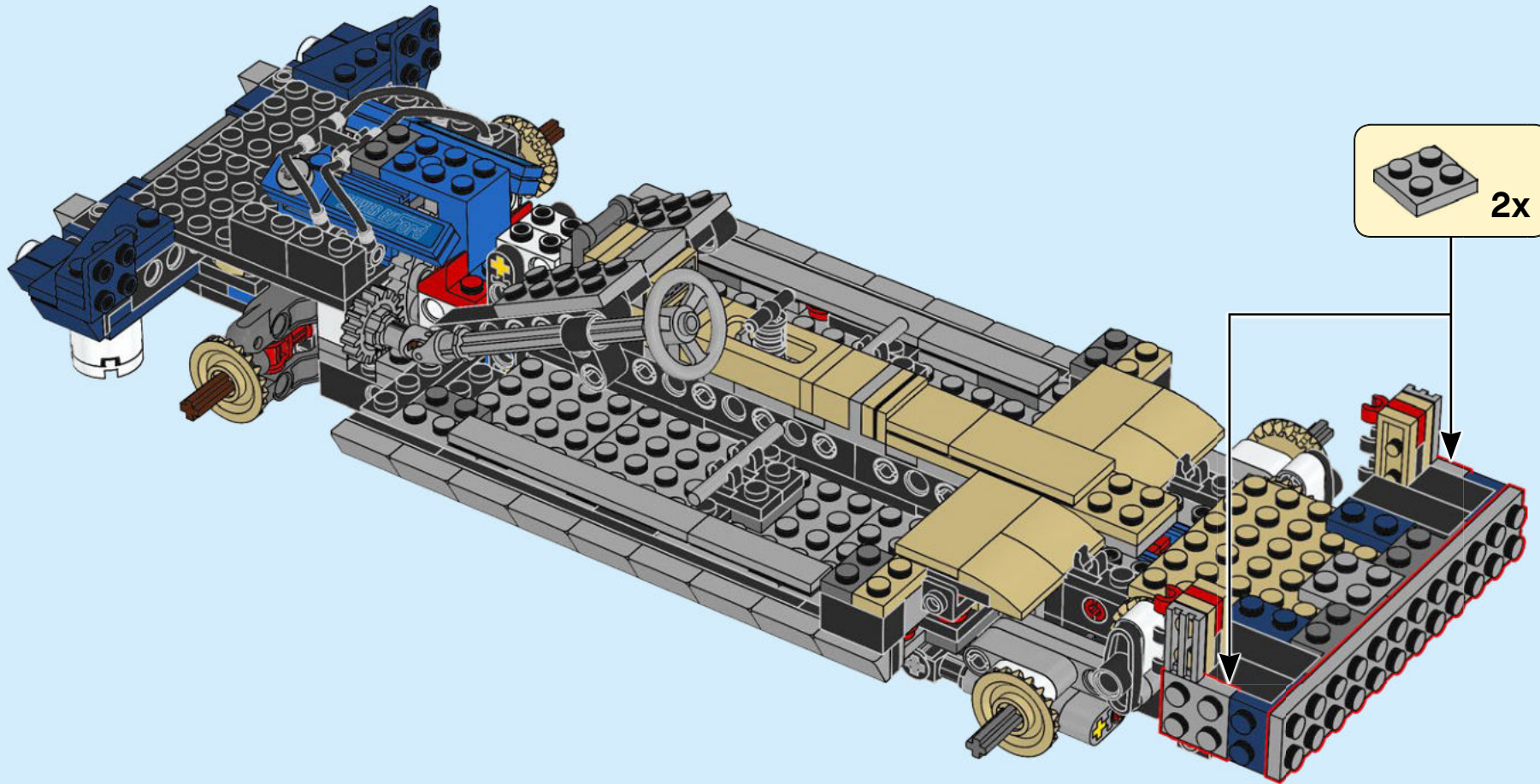

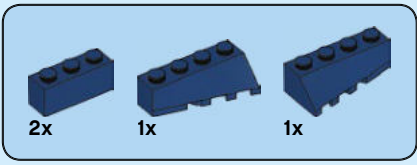

107

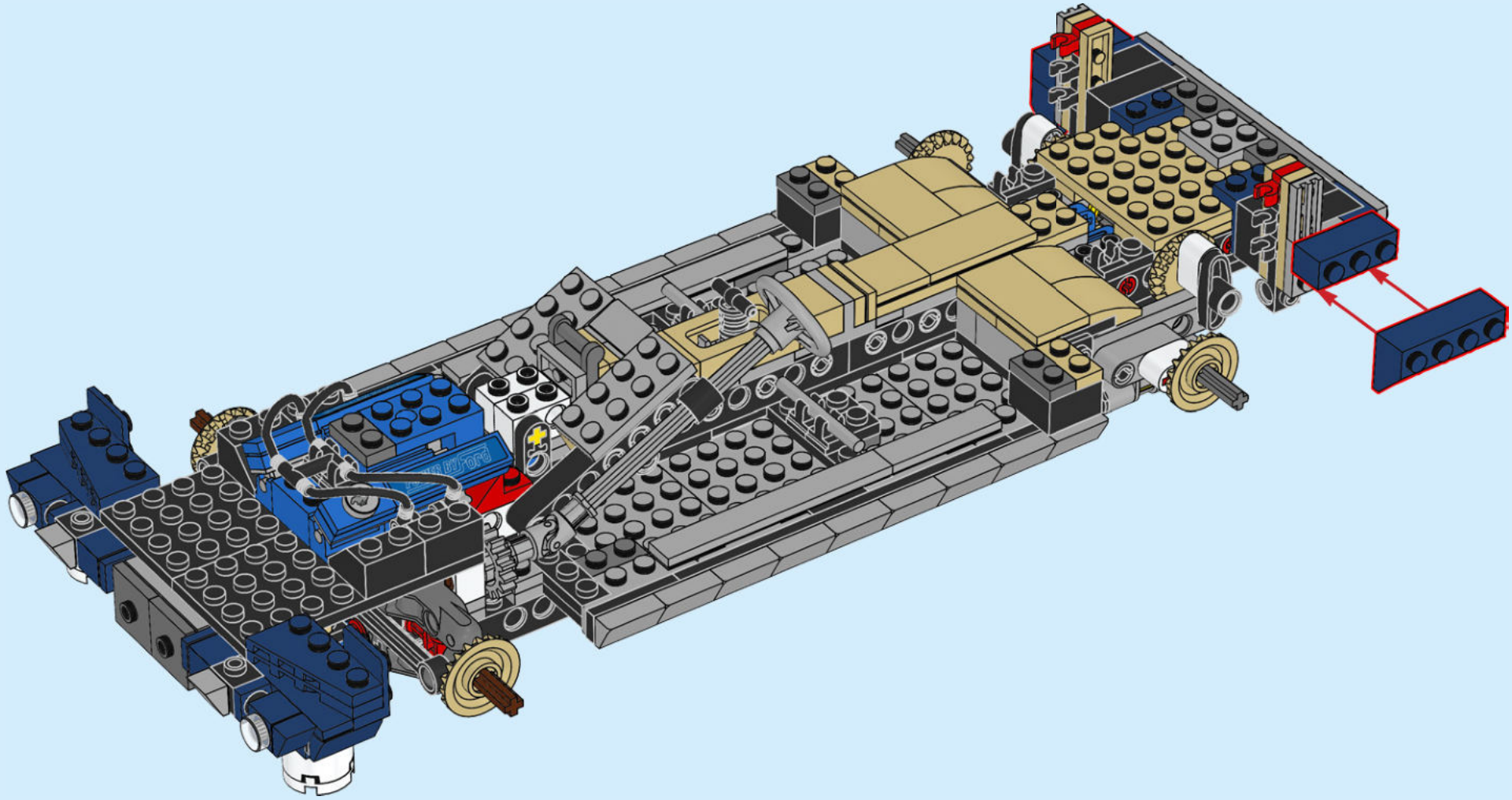

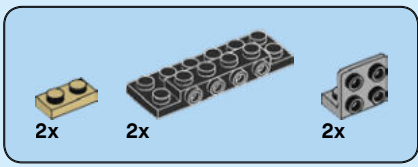

108

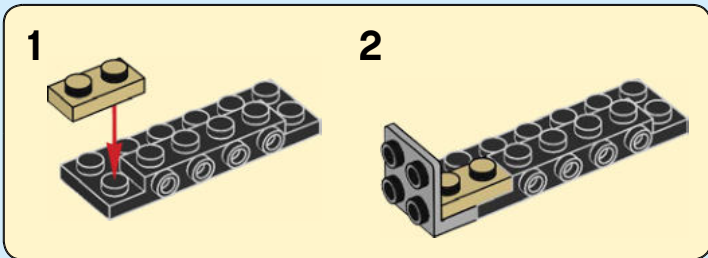
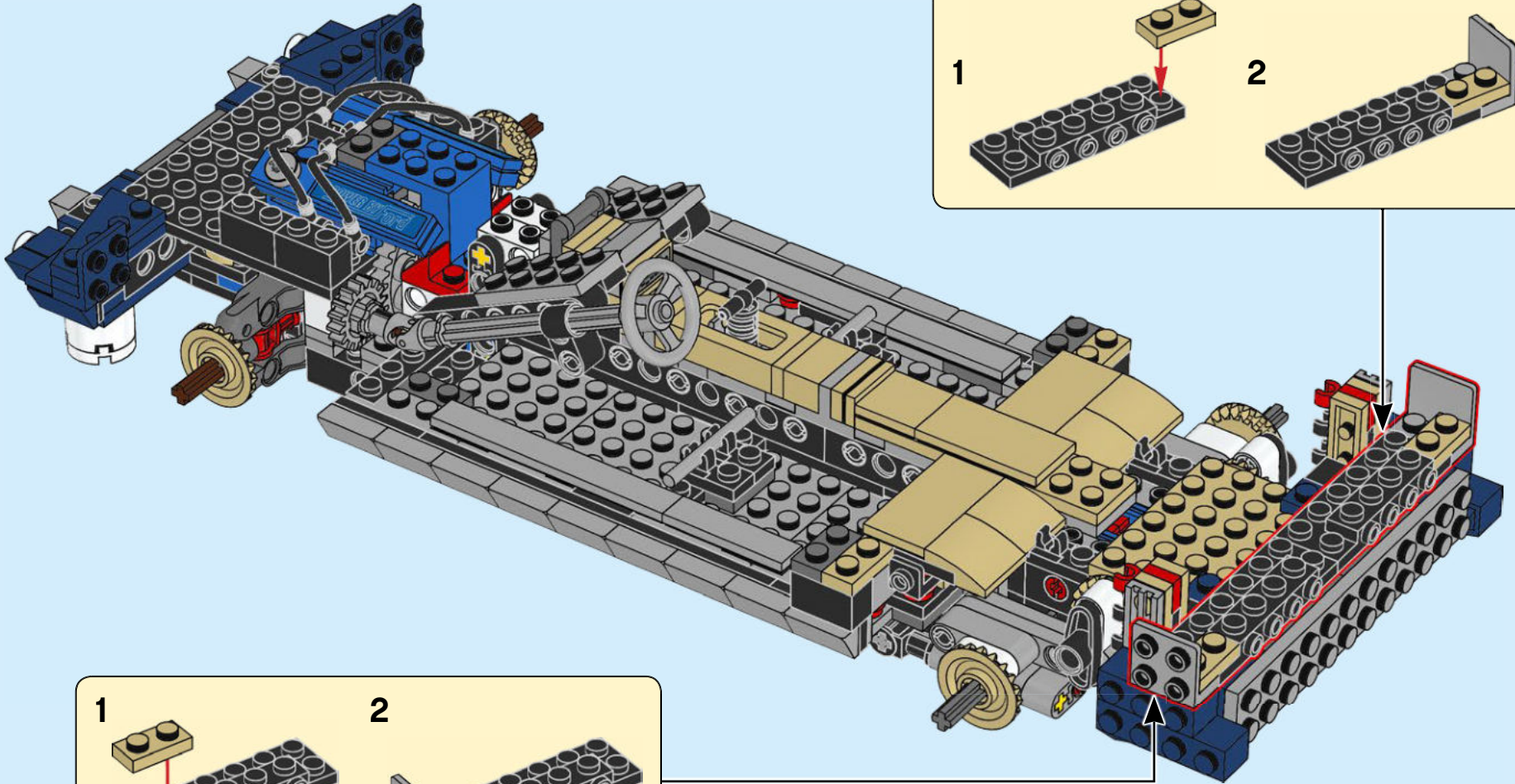
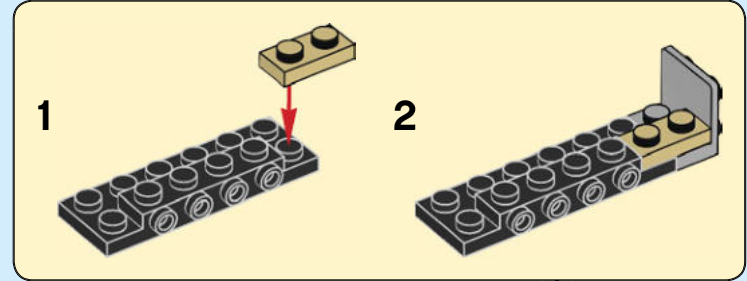

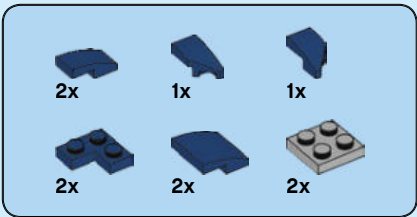

109

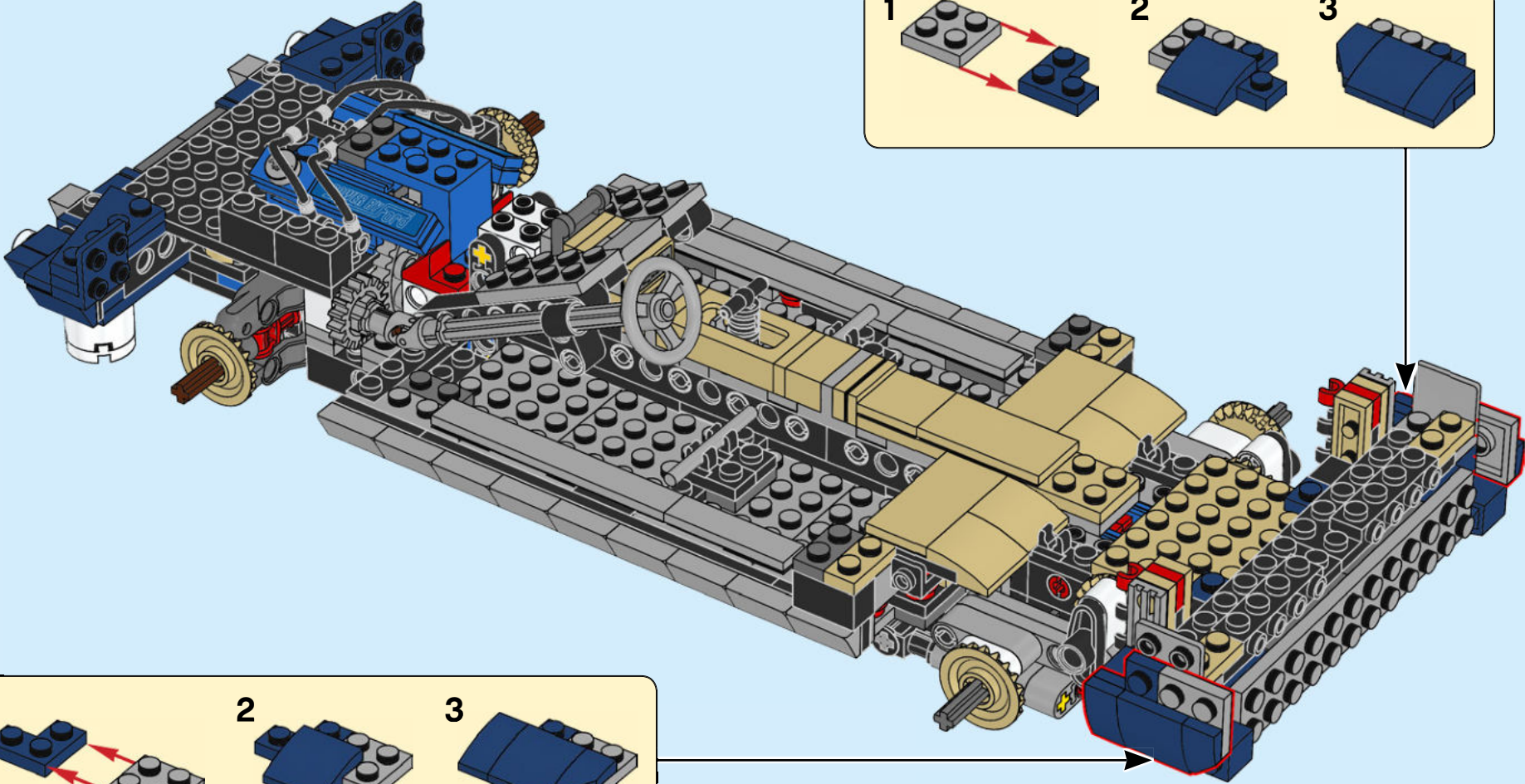
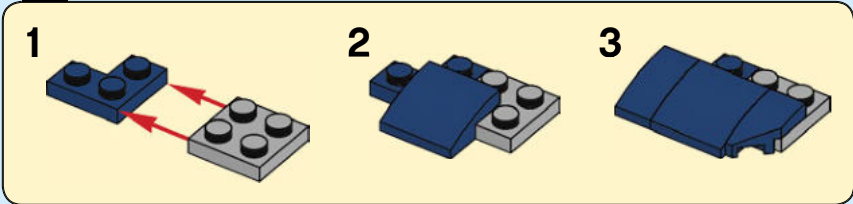
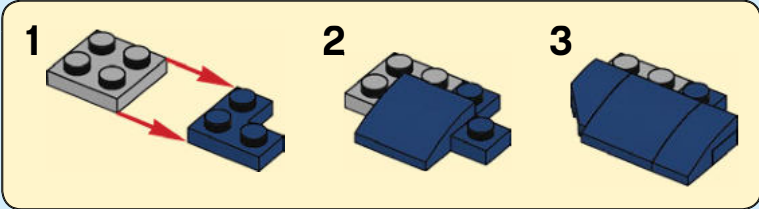

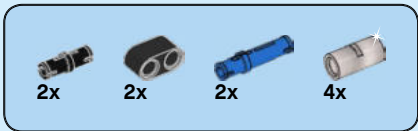

110

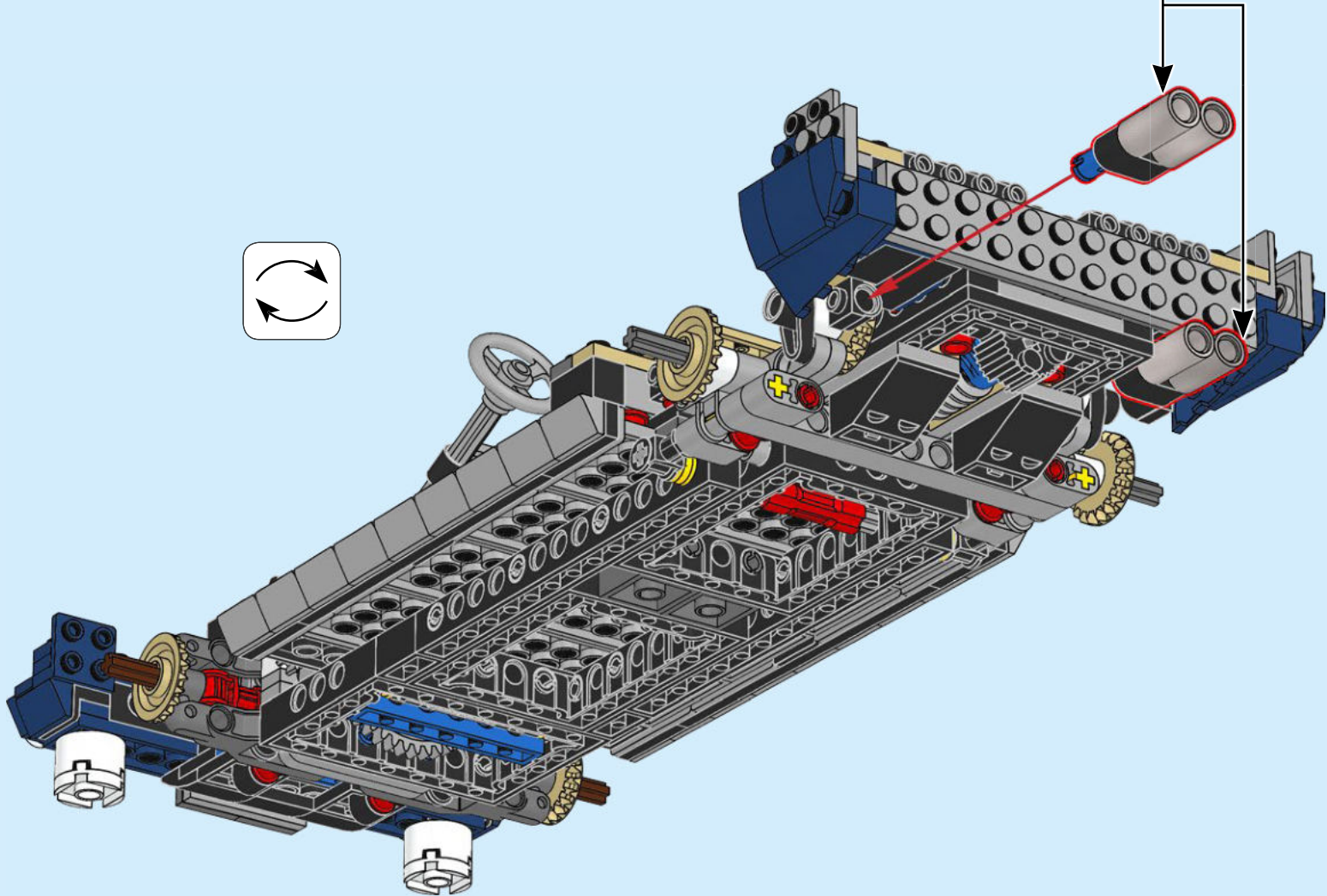
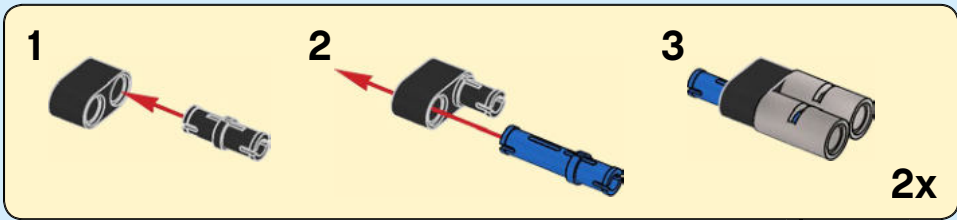

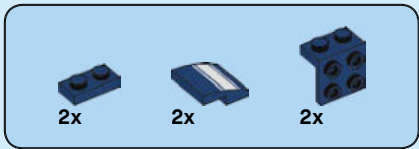

111

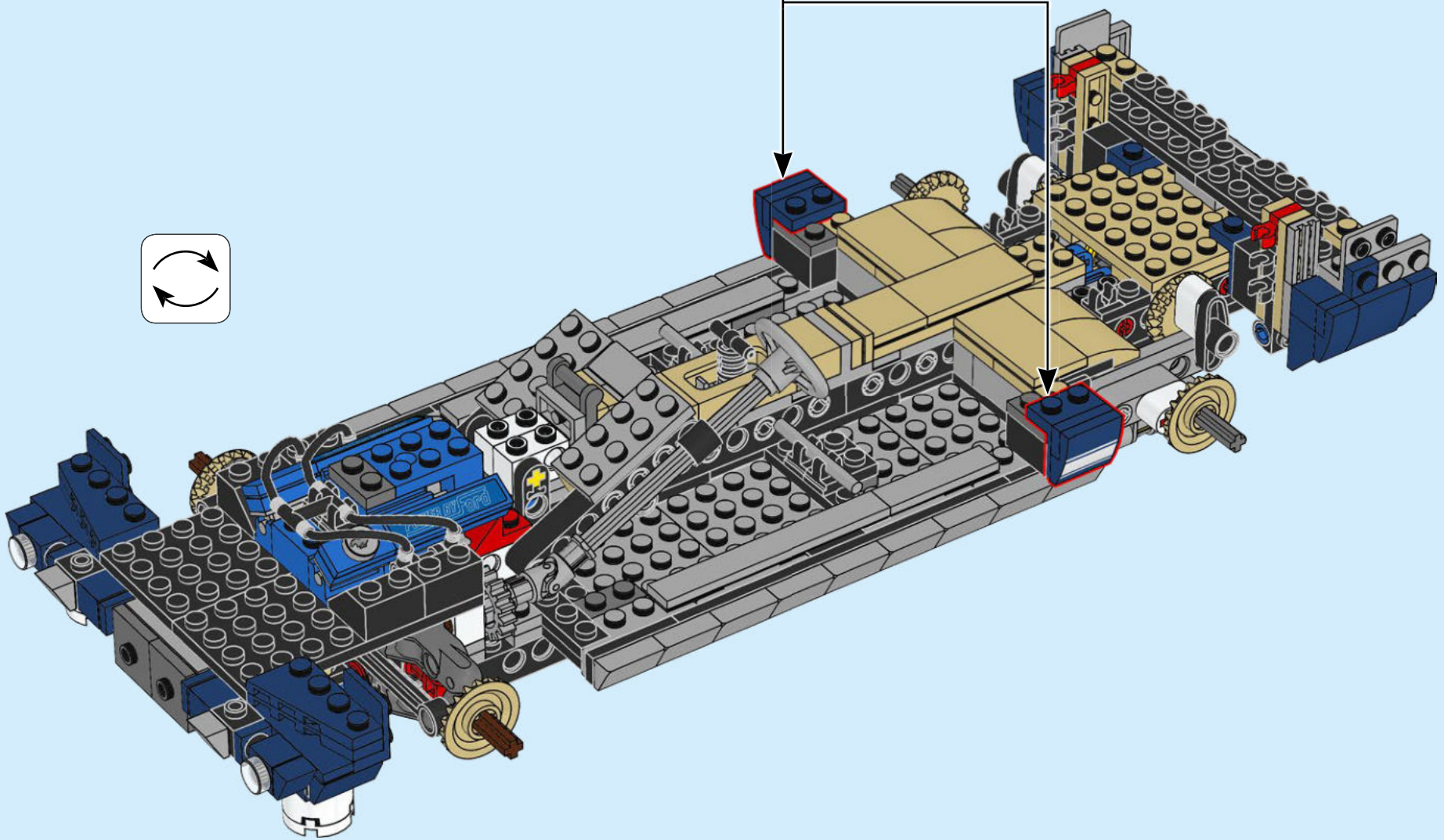
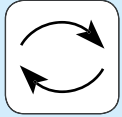
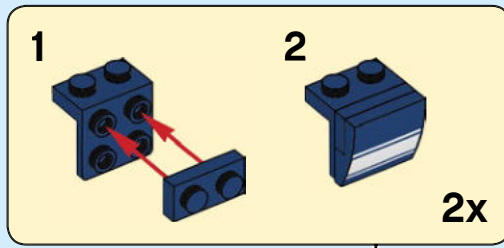

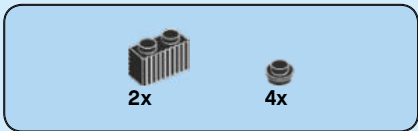

112

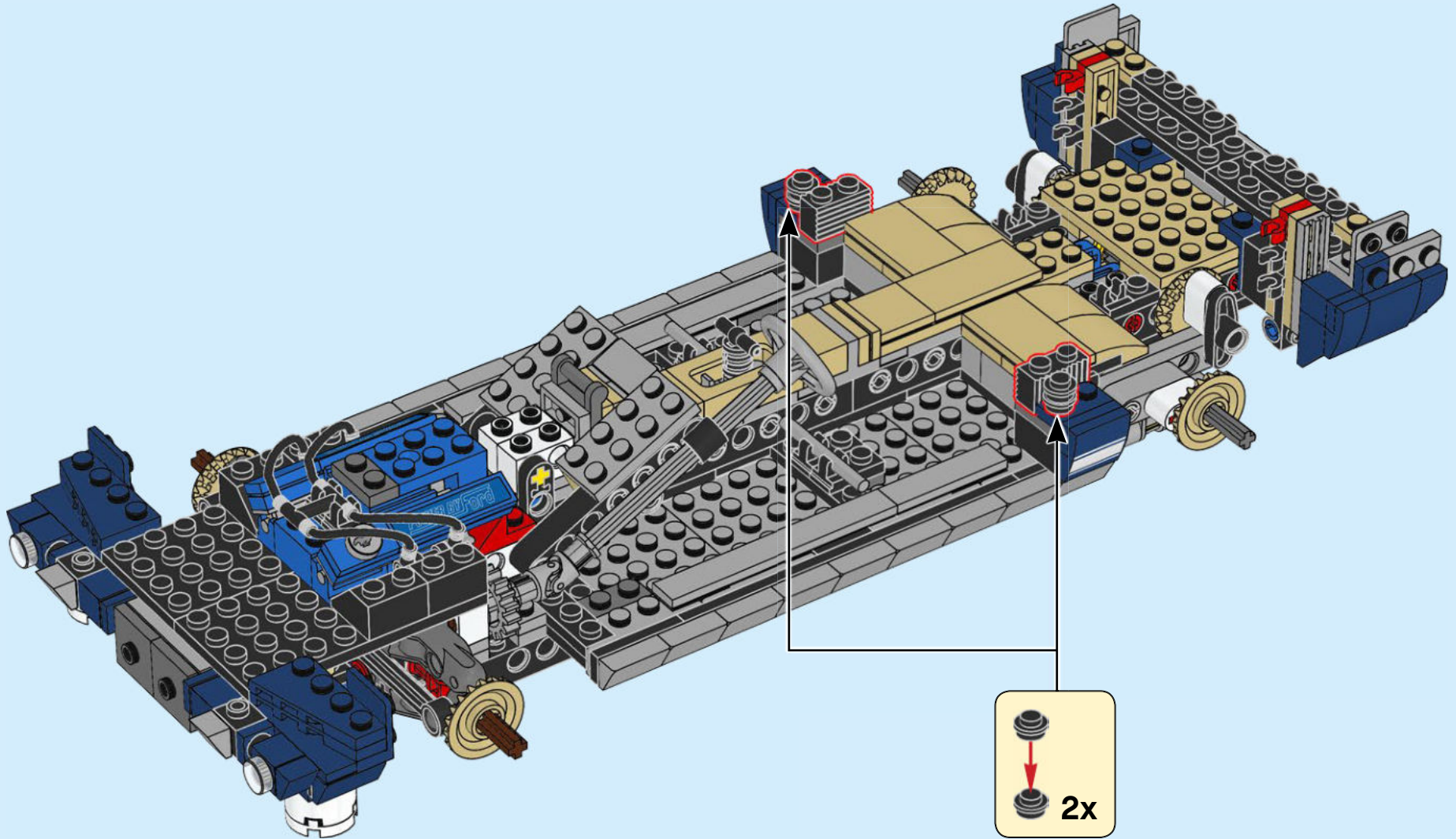

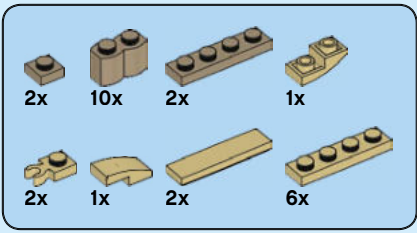

113

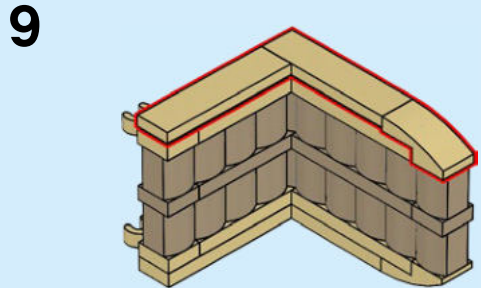
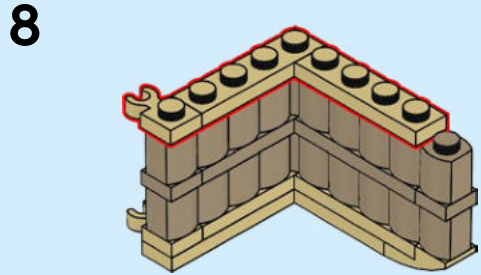
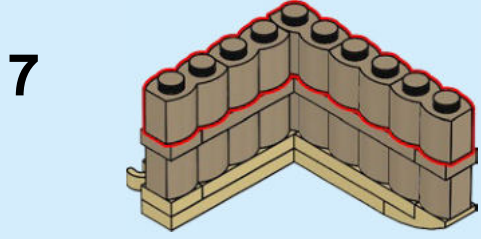
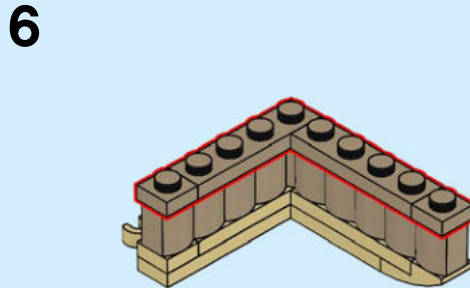
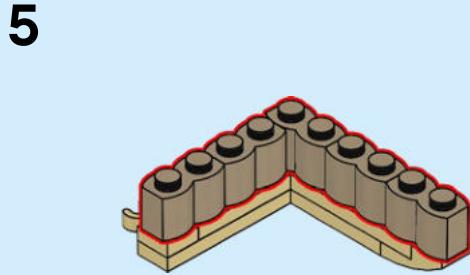
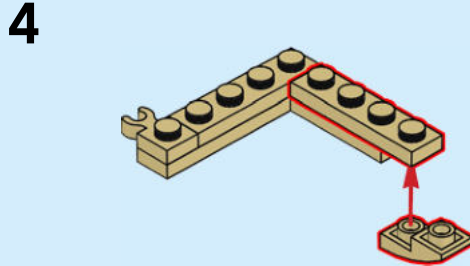
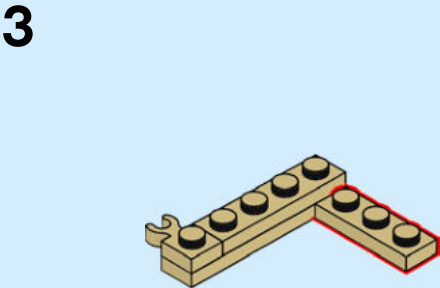
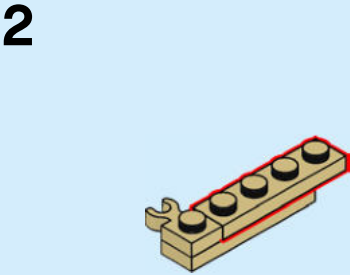
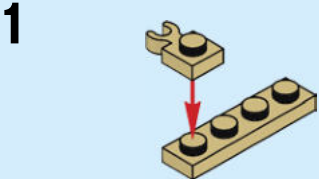

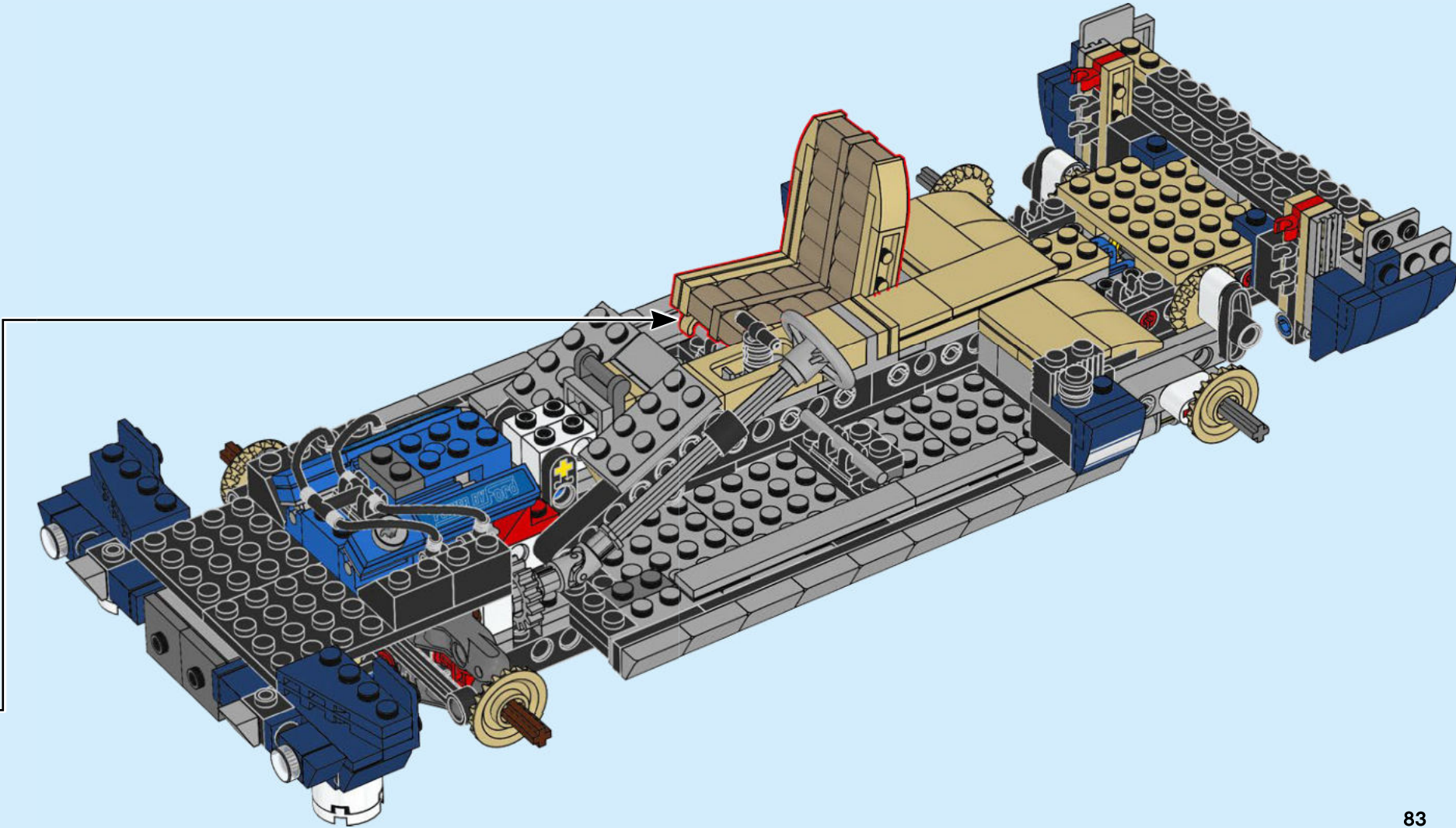

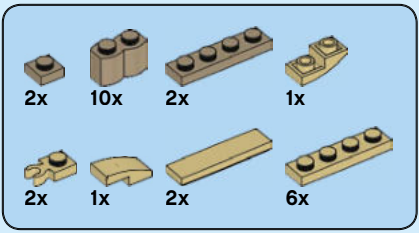

114

1

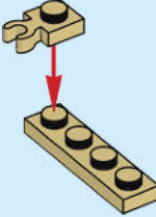

2

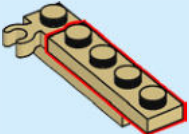

3

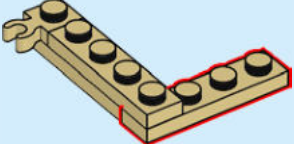

4

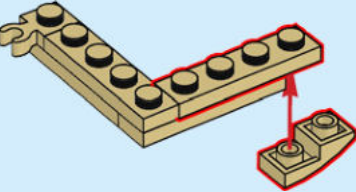

5

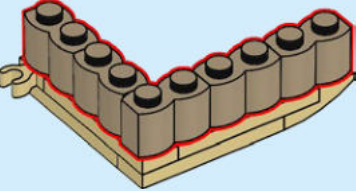

6

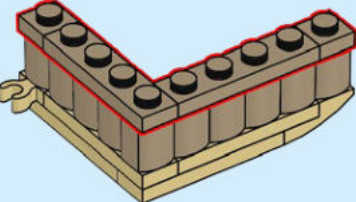

7

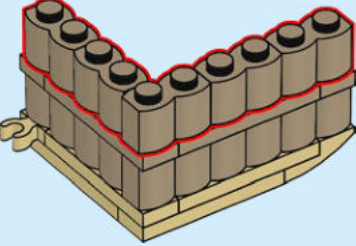

8

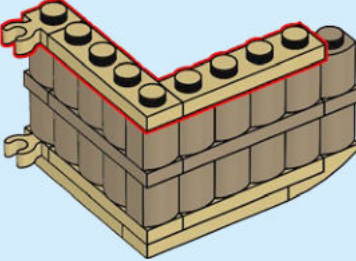

9

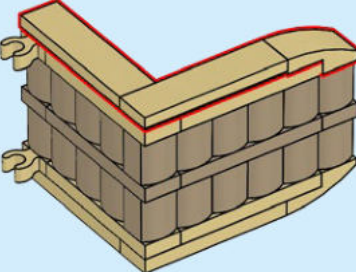

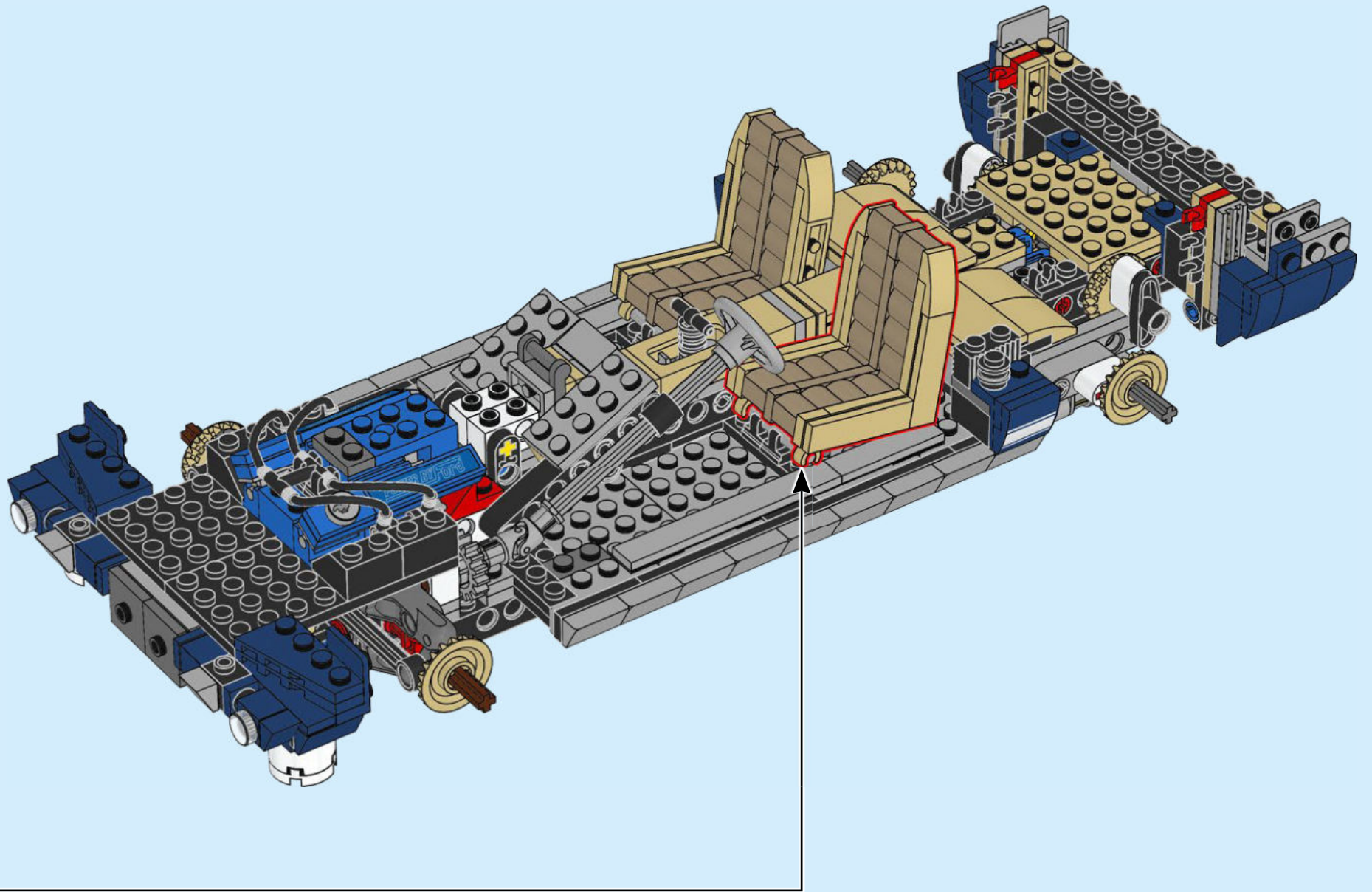

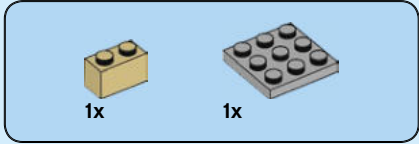
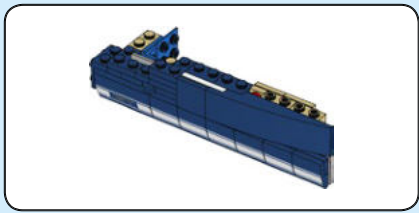

115

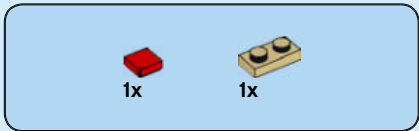
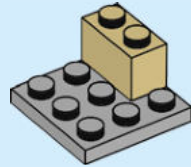

116

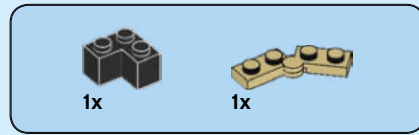
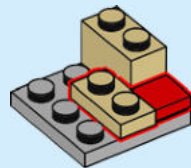

117

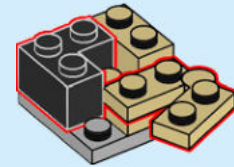

118

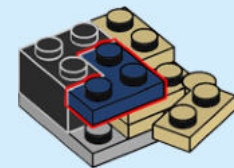

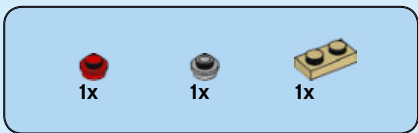

119

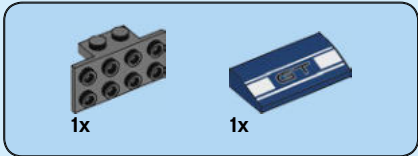
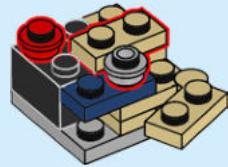

120

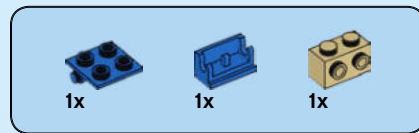
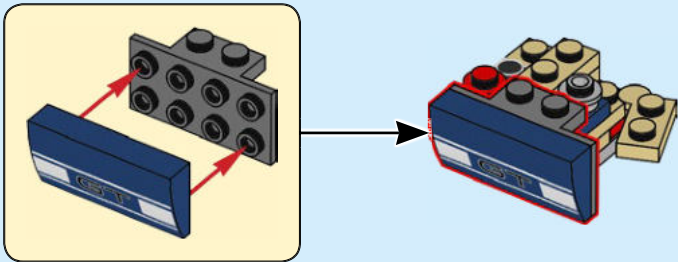

121

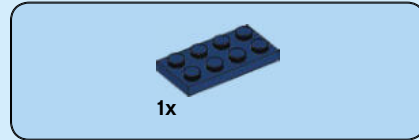
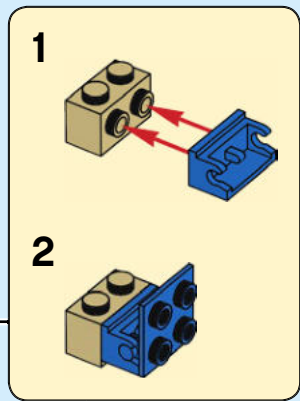
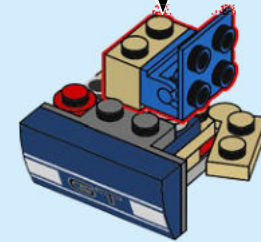

122

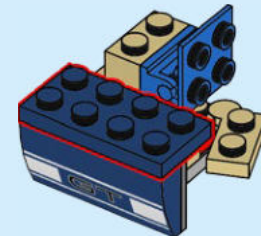

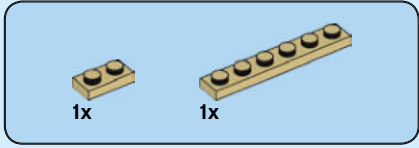

123

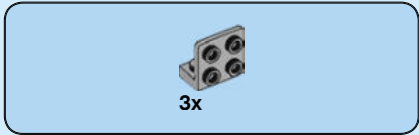
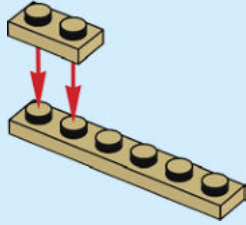

124

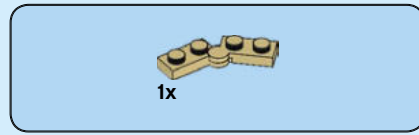
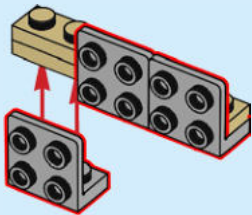

125

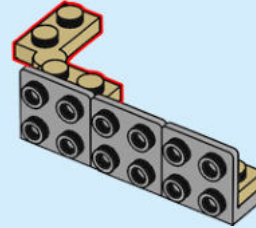

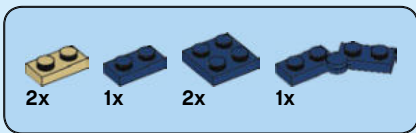

126

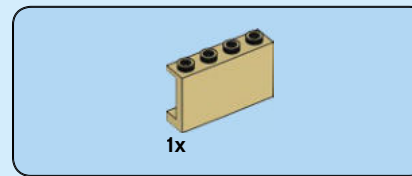
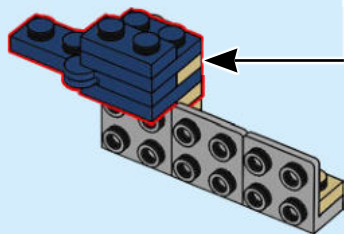
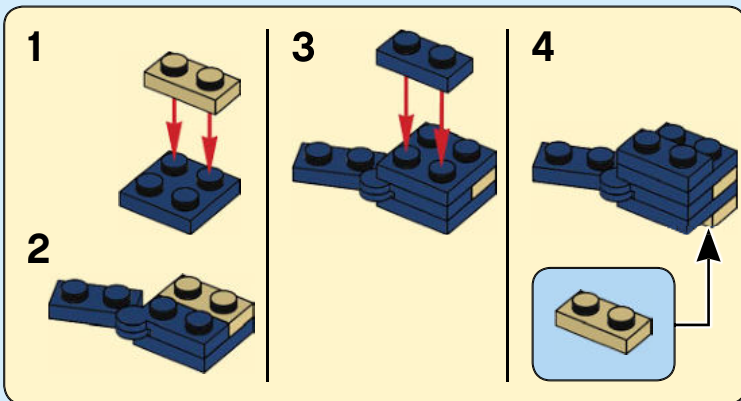

127

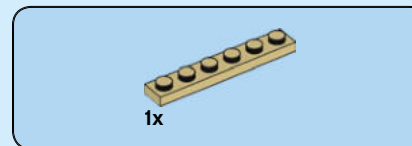
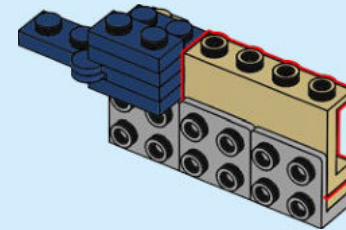

128

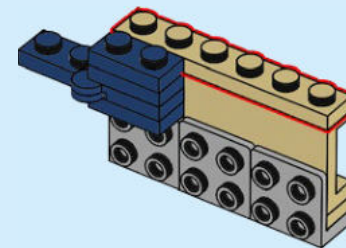

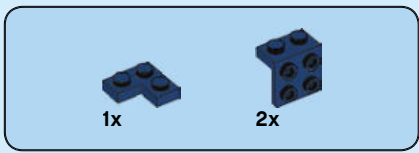

129

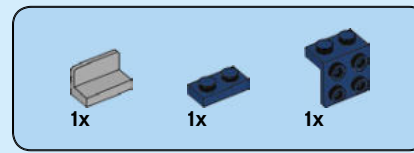
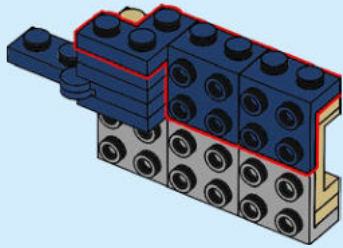

131

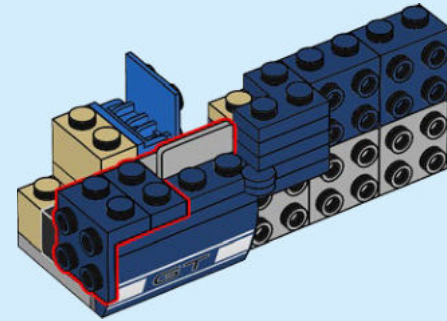

130

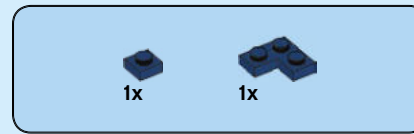
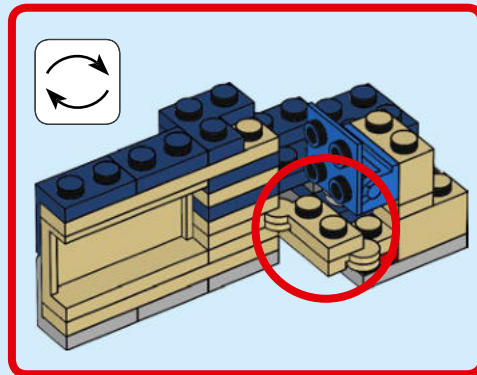
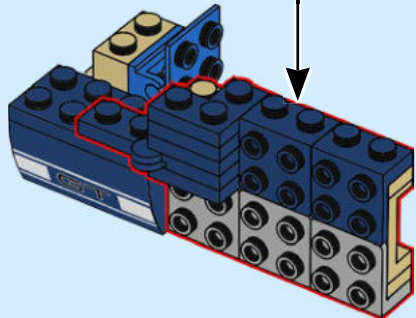

132

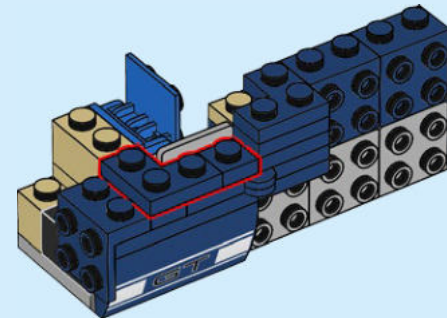



133

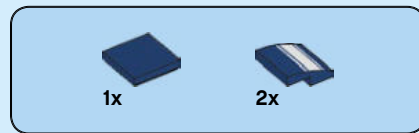
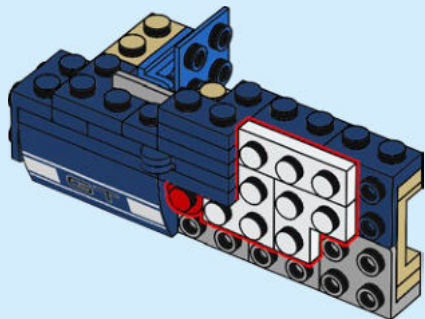

134

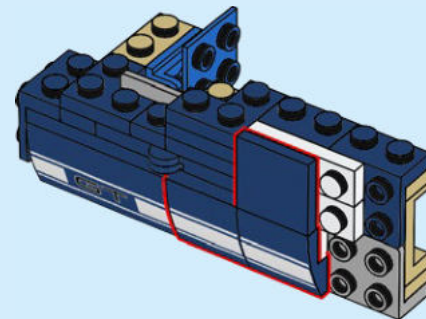

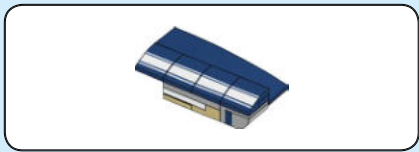

135

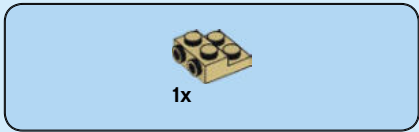
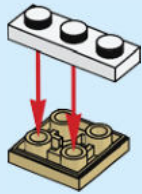

136

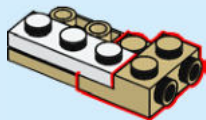

137

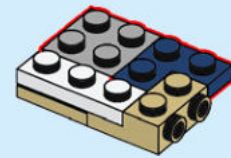

138

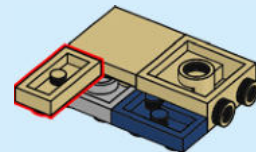
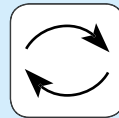



139

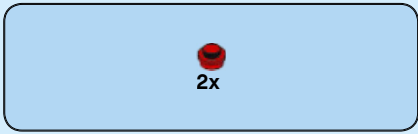
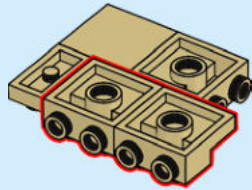

140

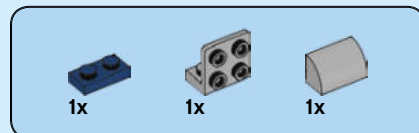
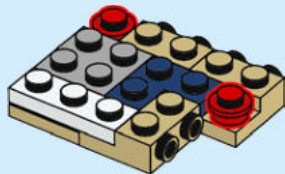
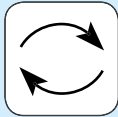

141

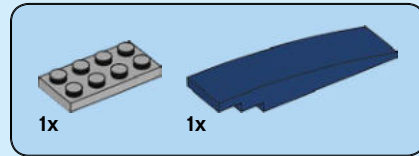
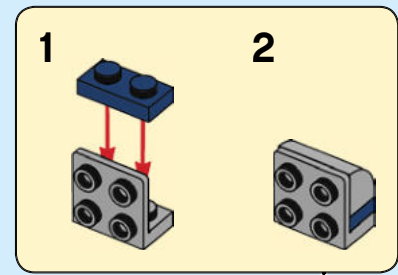
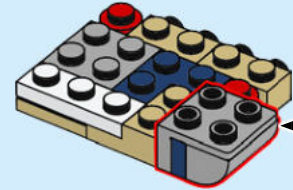

142

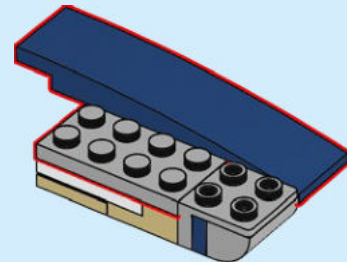

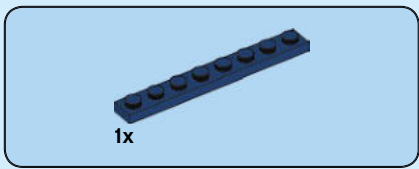

143

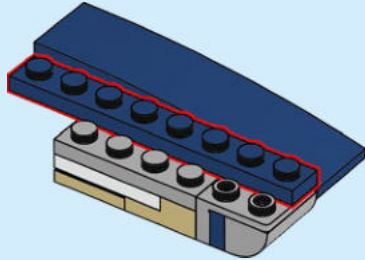

144

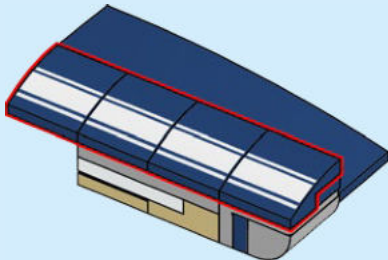

145

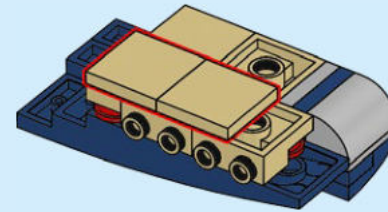
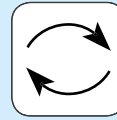

146

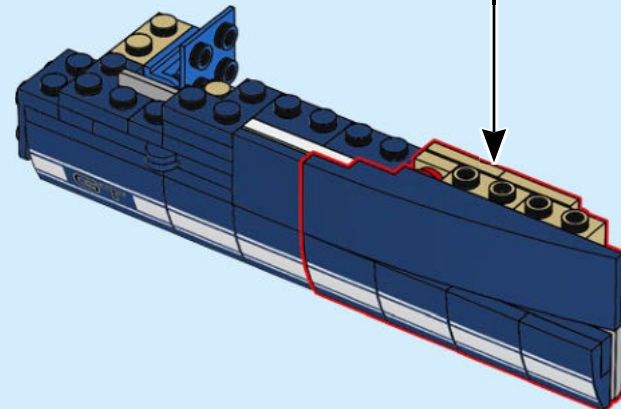

147

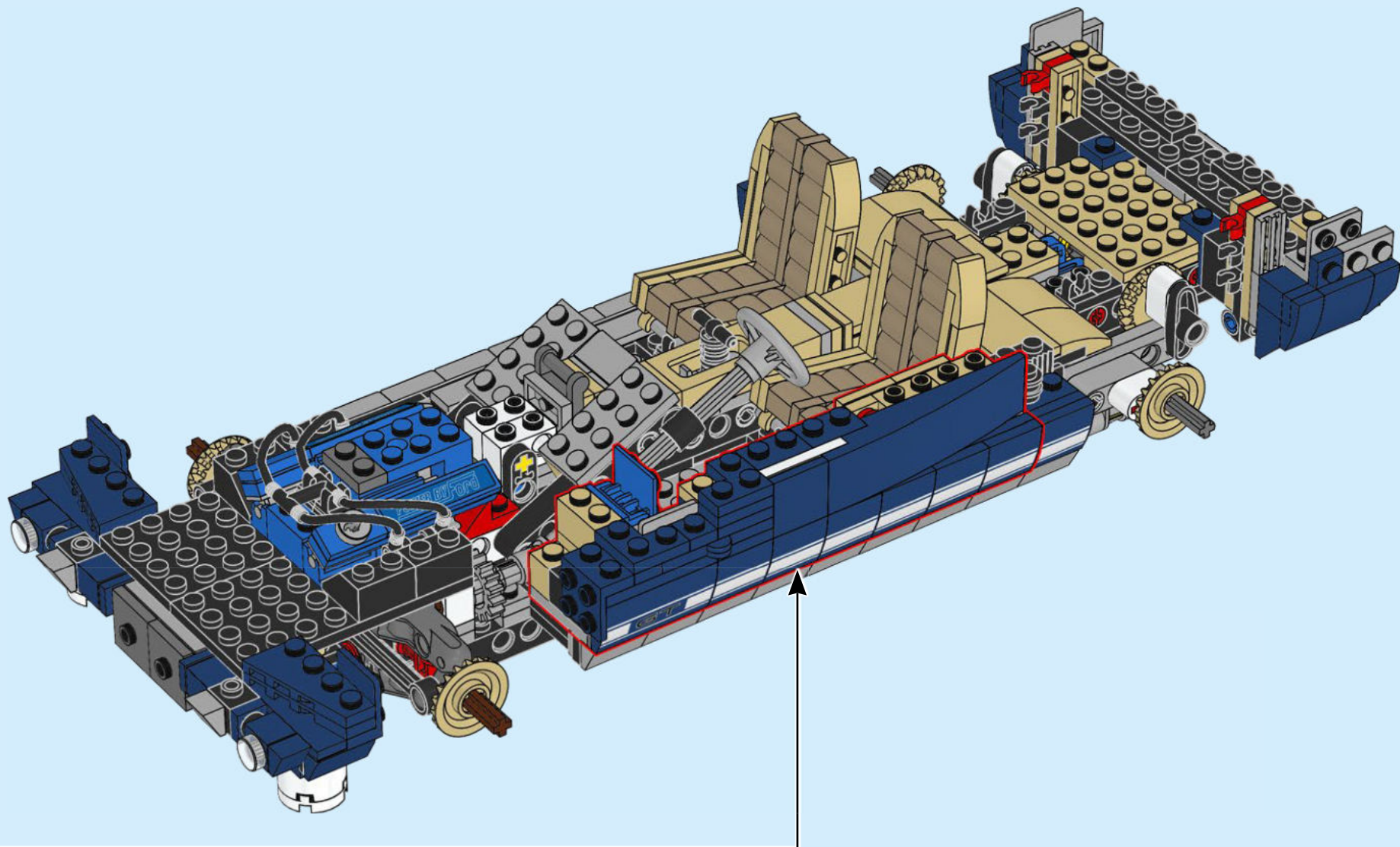

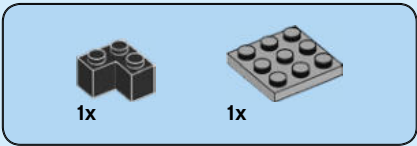
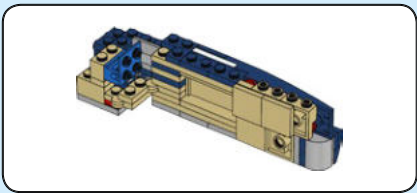

148

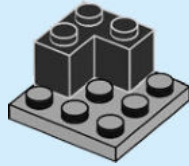

149

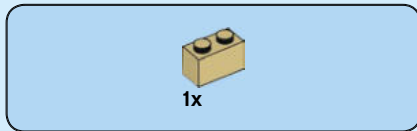
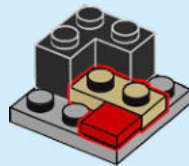

150

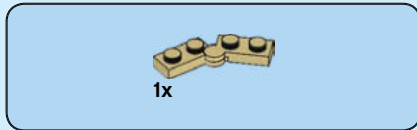
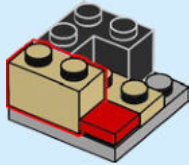

151

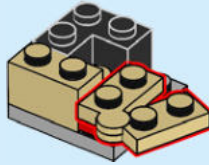

152

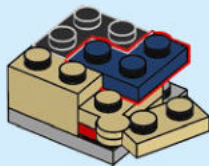

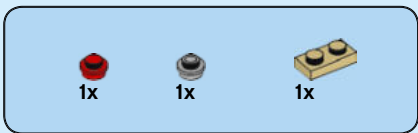

153

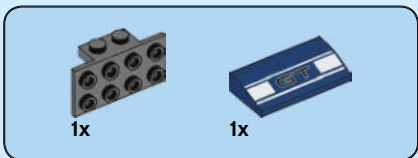
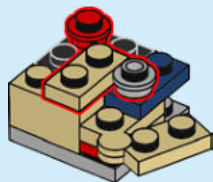

154

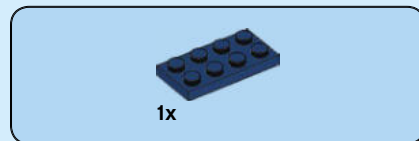
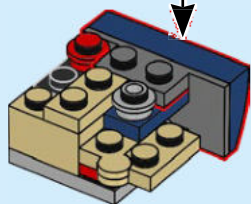
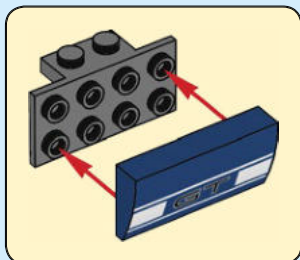

155

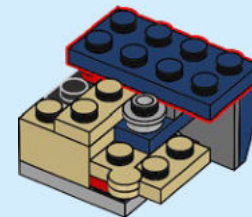

156

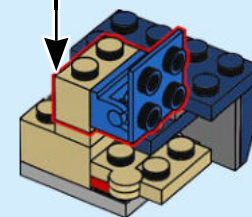
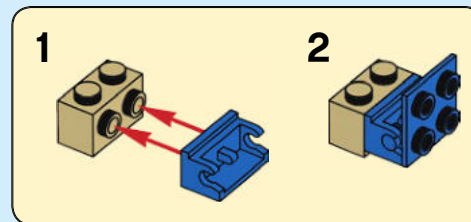

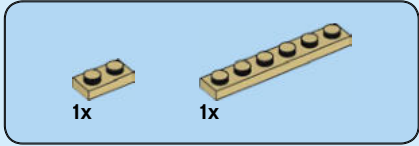
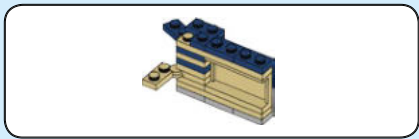

157

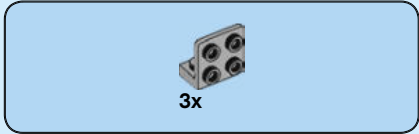
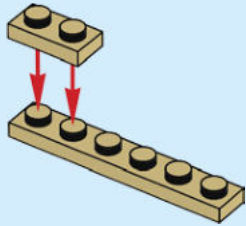

158

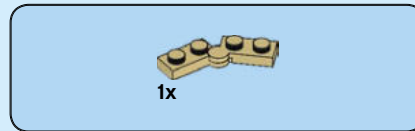
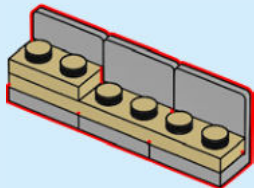

159

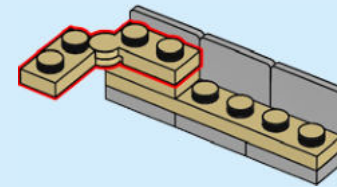

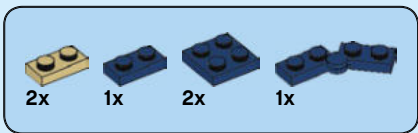

160

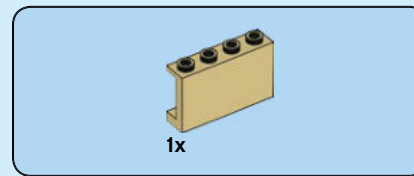
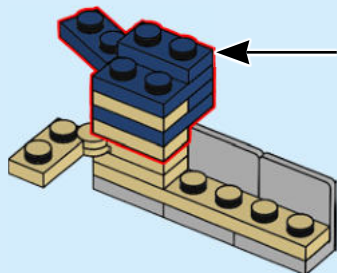
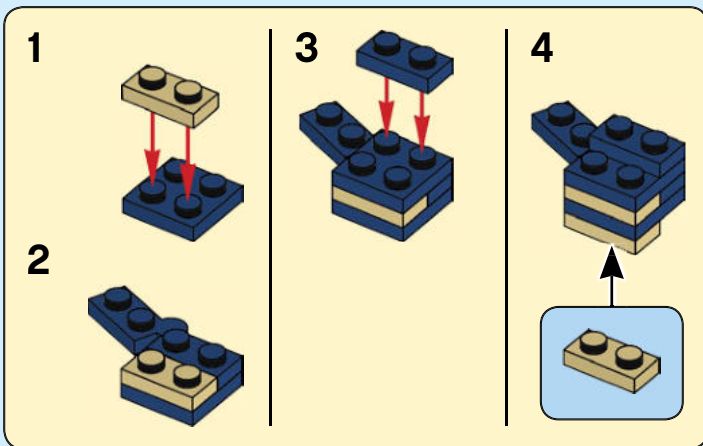

161

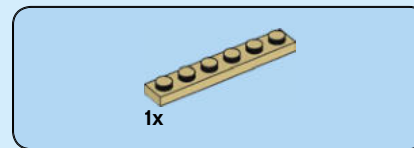
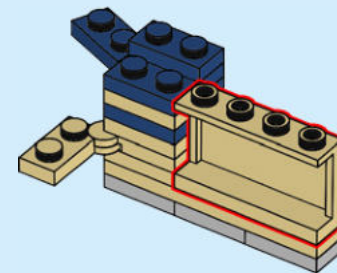

162

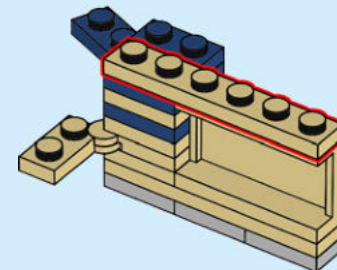

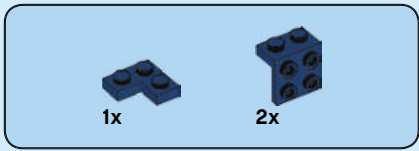

163

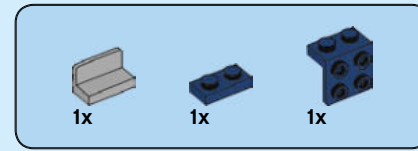
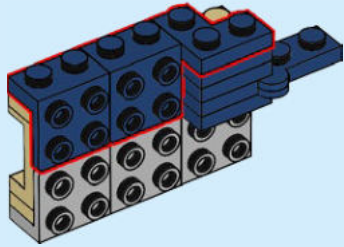
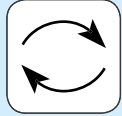

165

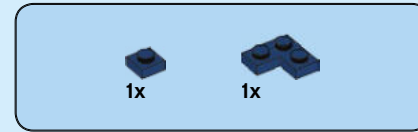
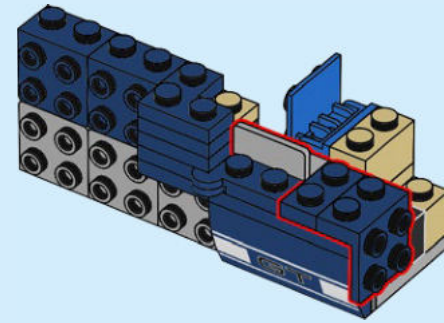

166

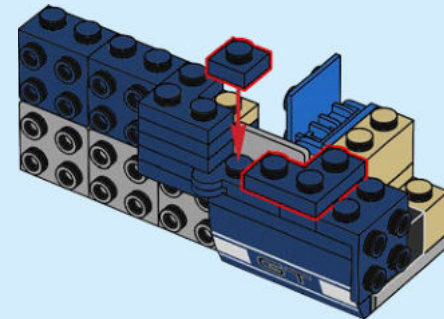

164

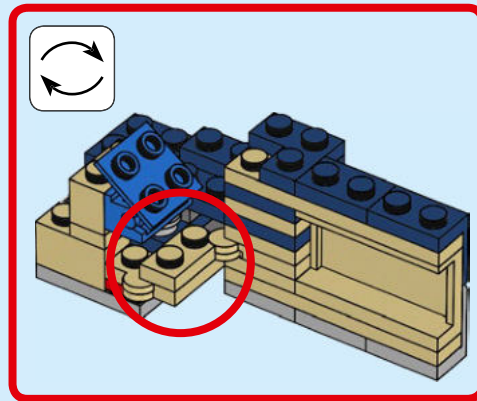
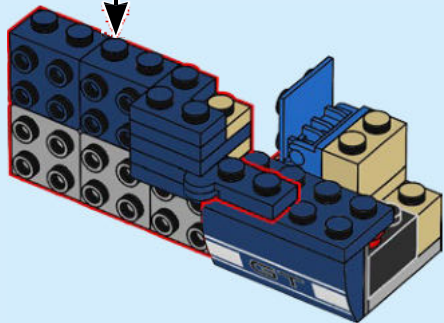



167

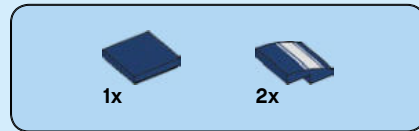
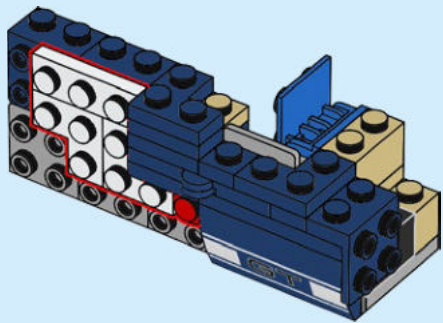

168

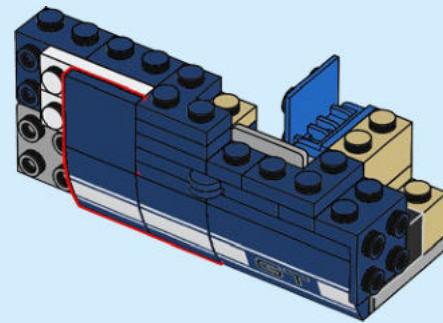

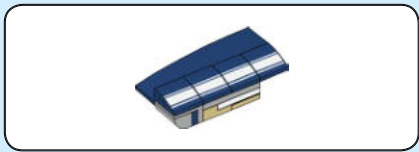

169

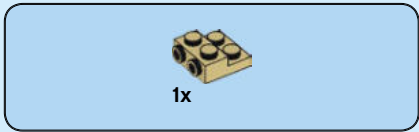
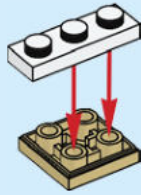

170

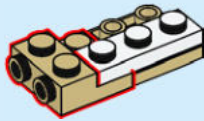

171

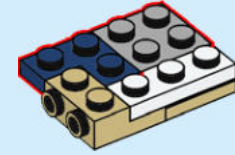

172

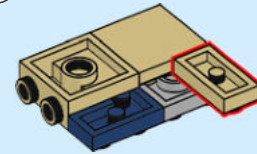
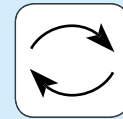

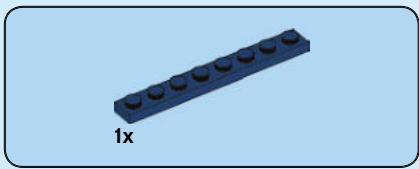

177

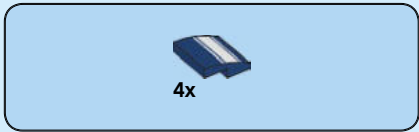
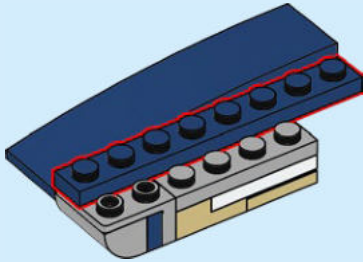

178

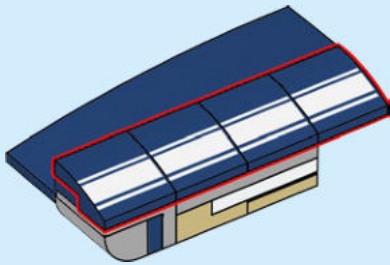

179

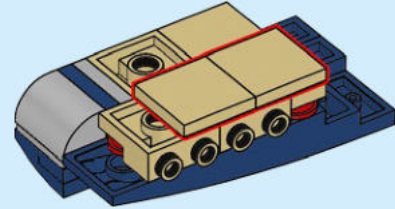
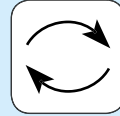

180

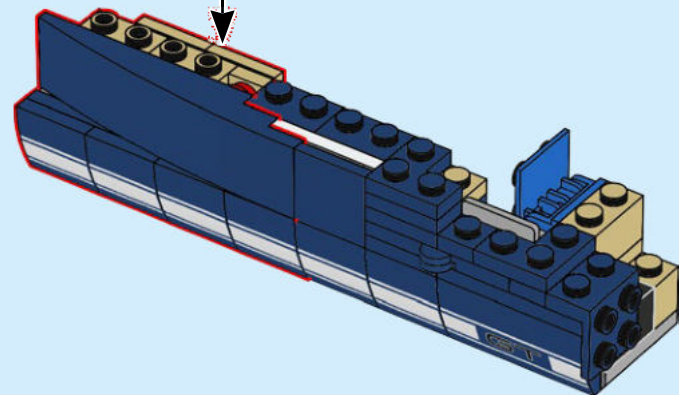

181

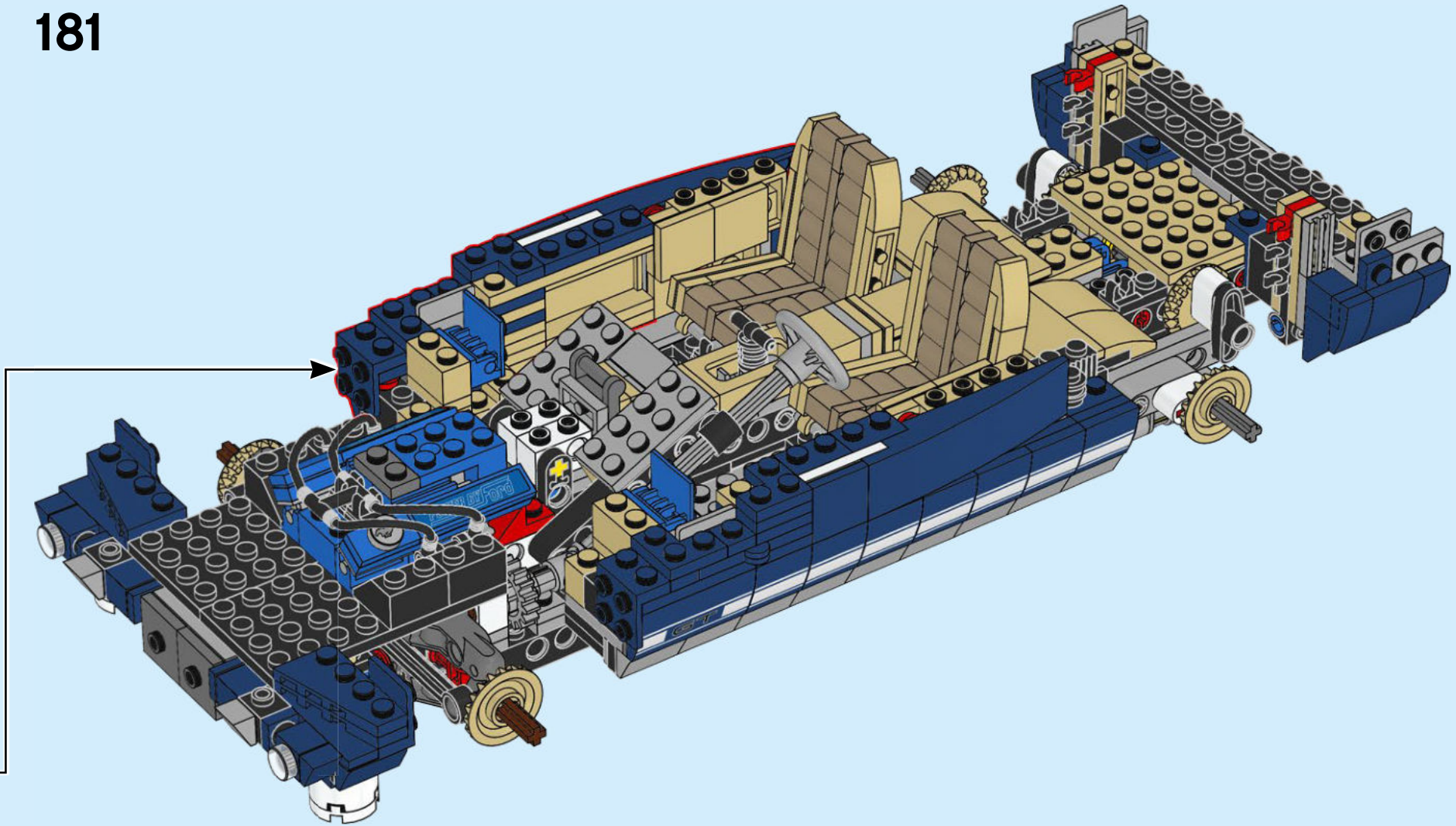

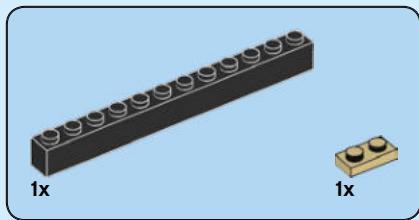

182

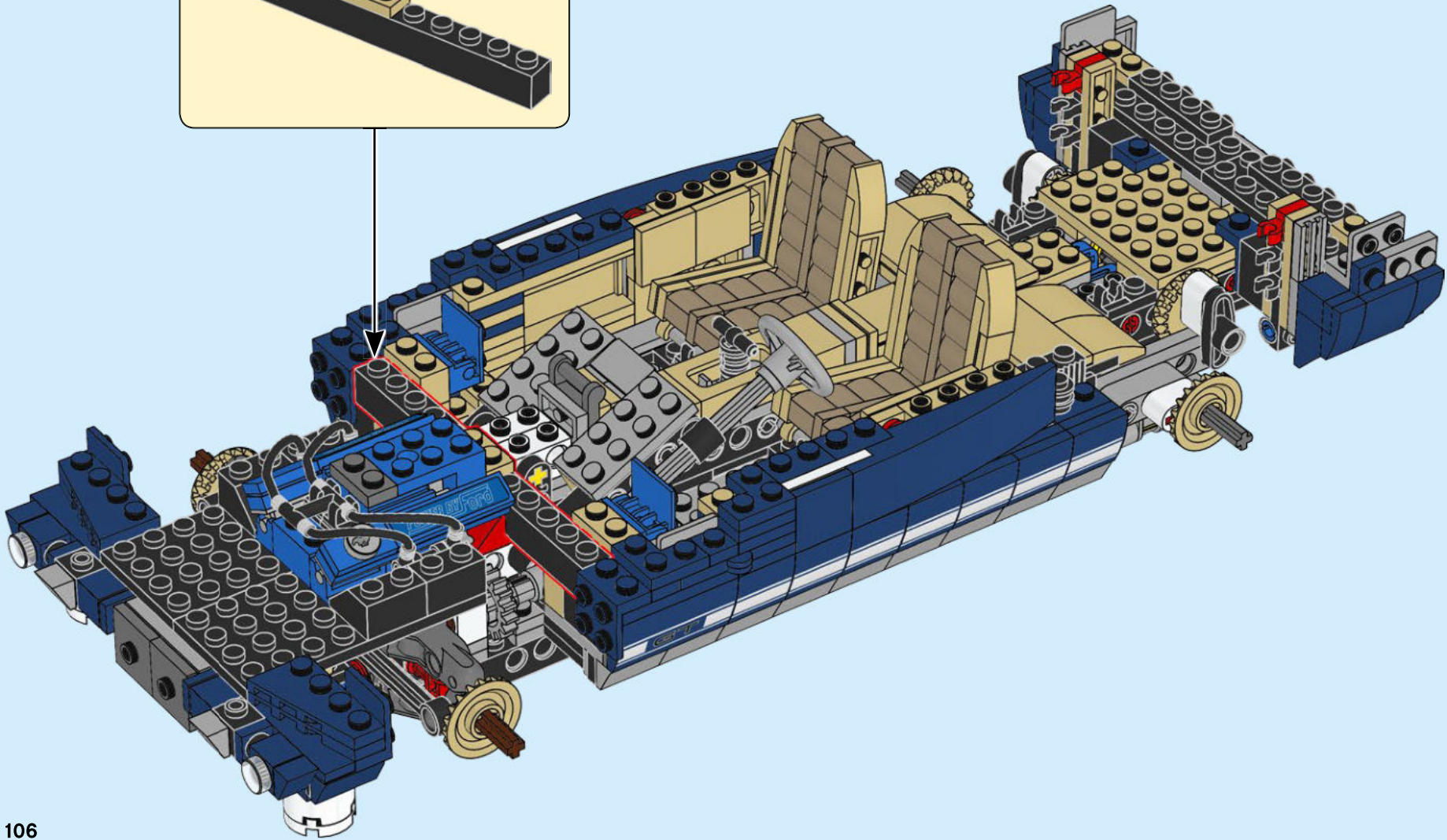
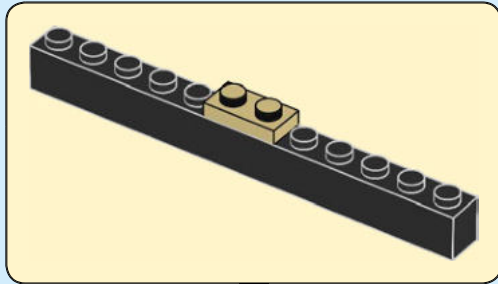

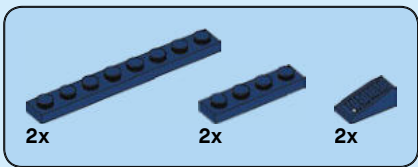

183

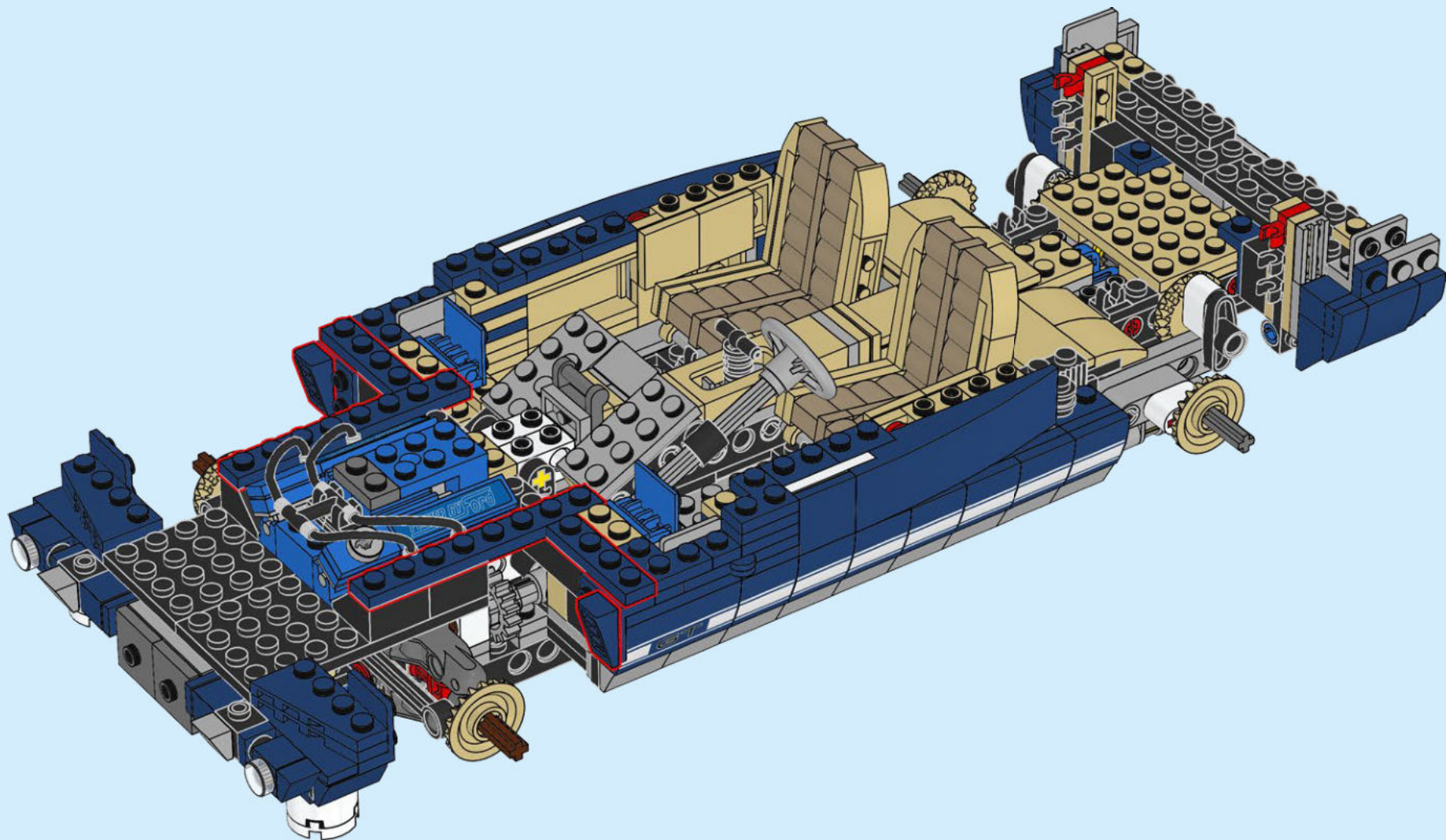

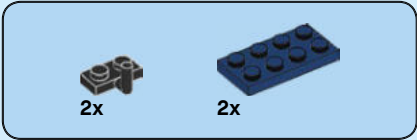

184

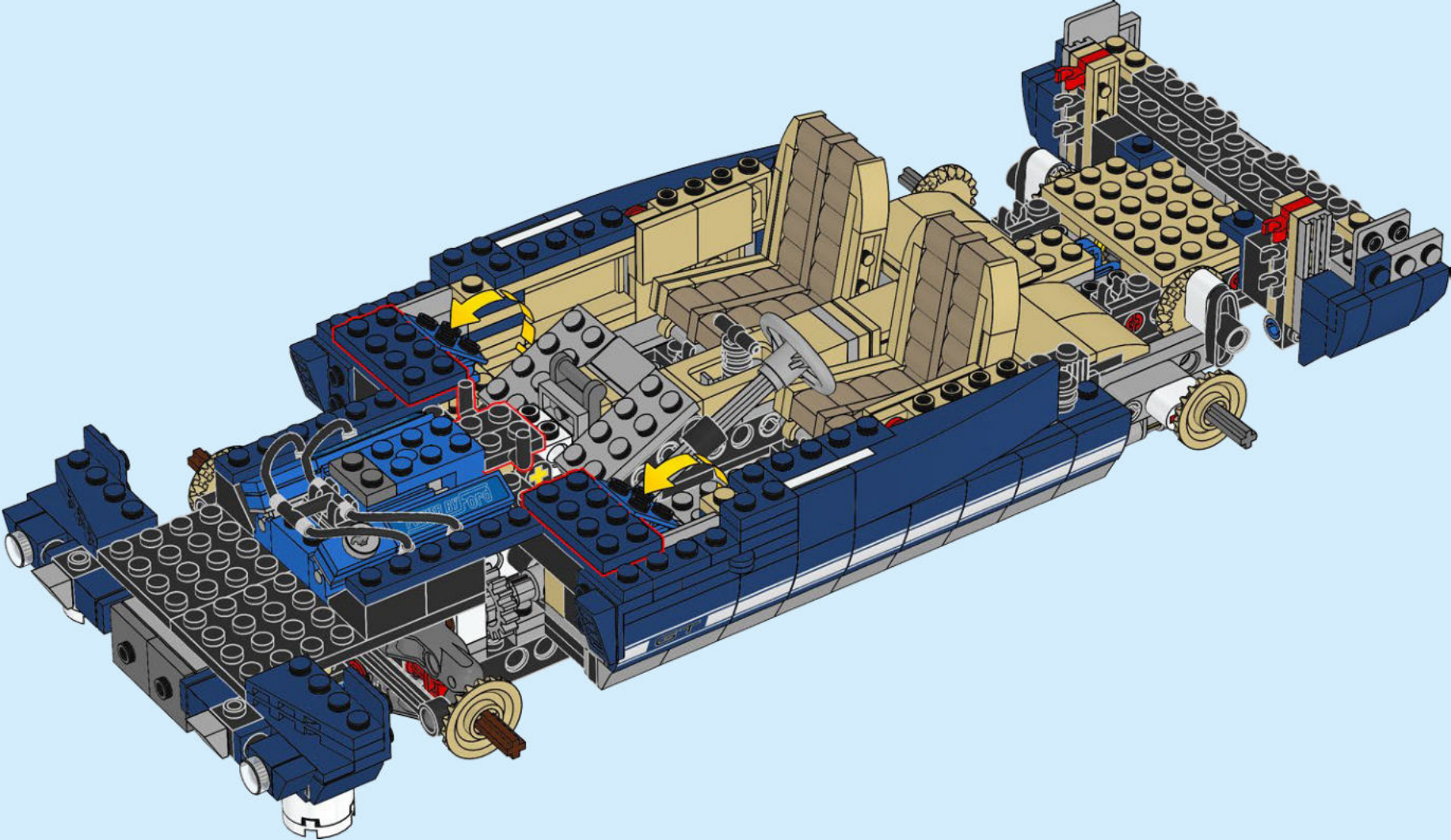

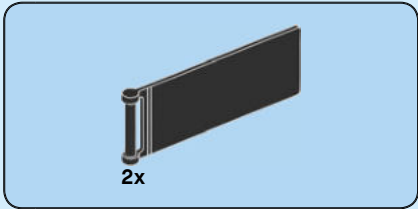
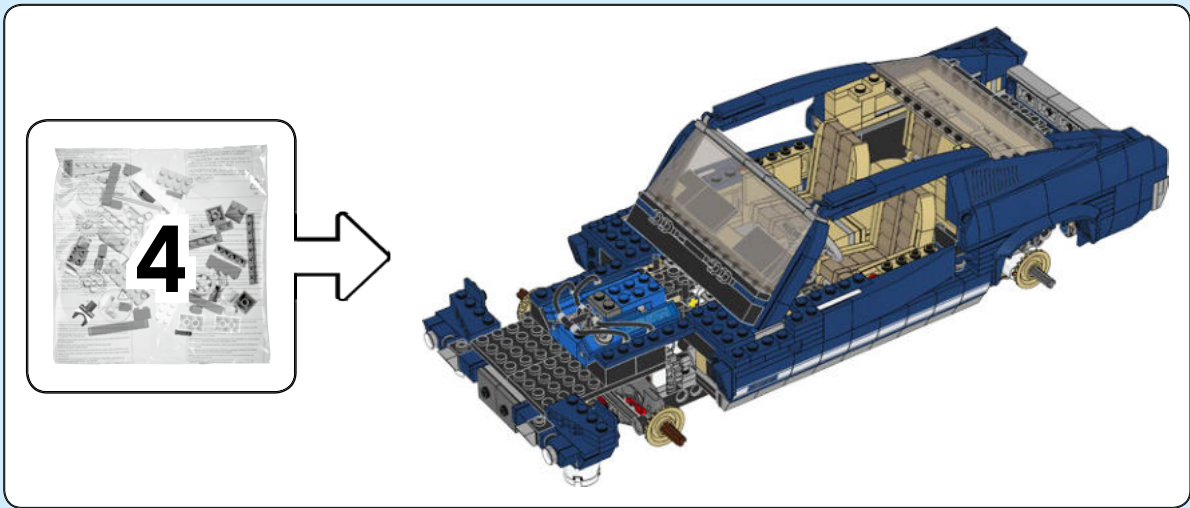

185

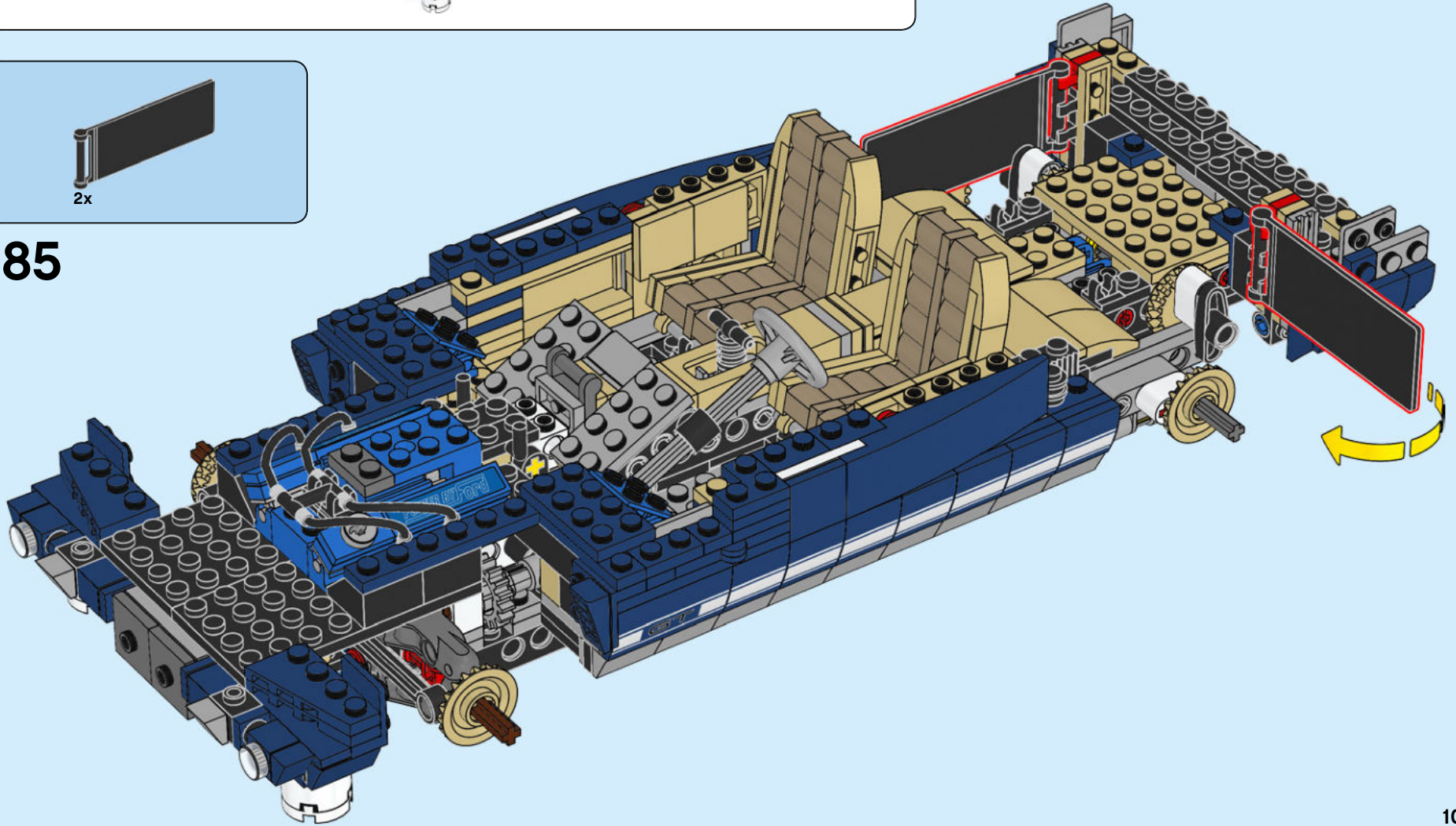



2x

186



2x

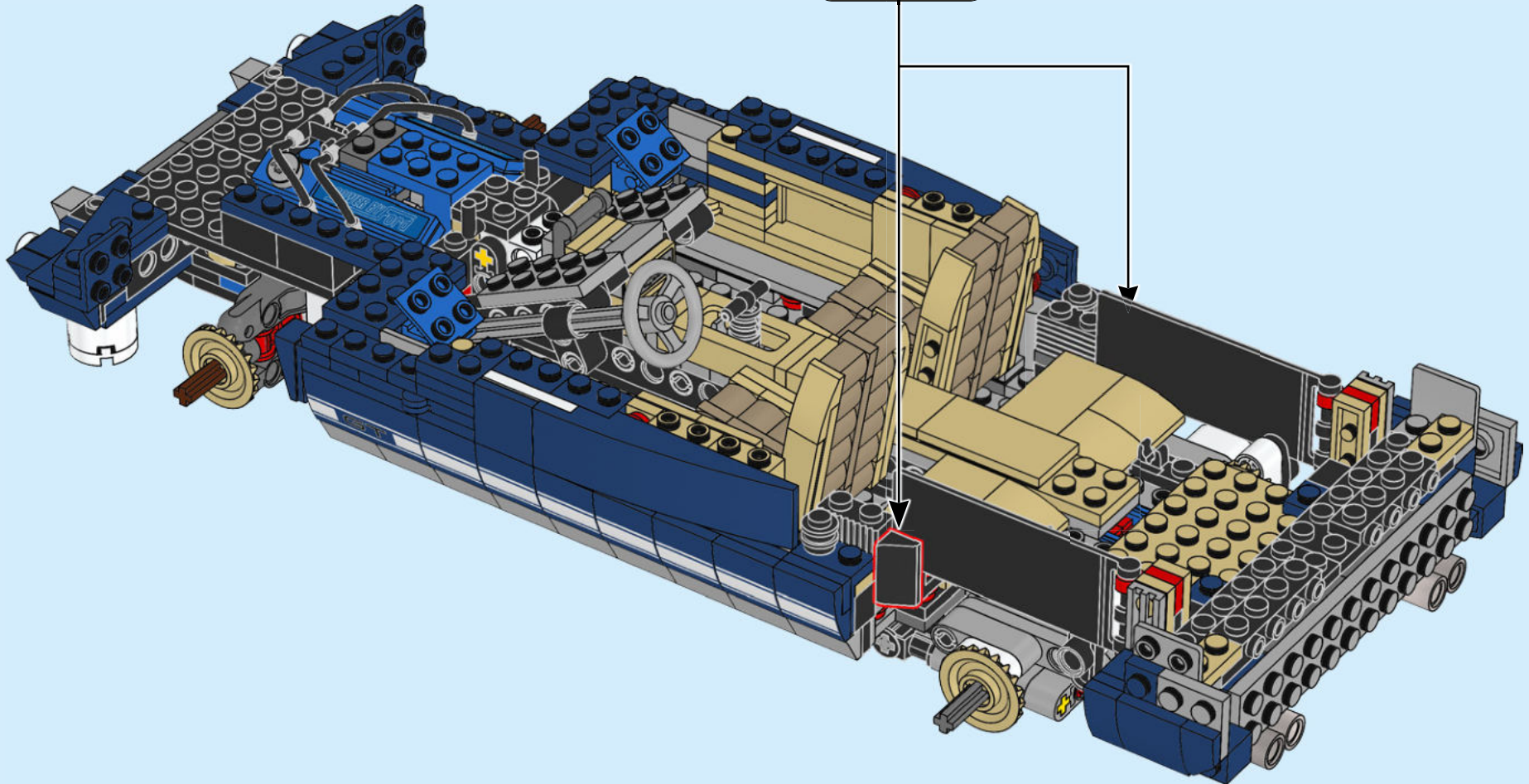

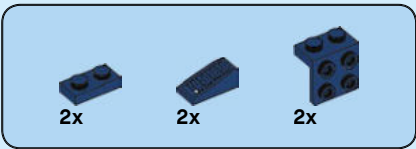

187

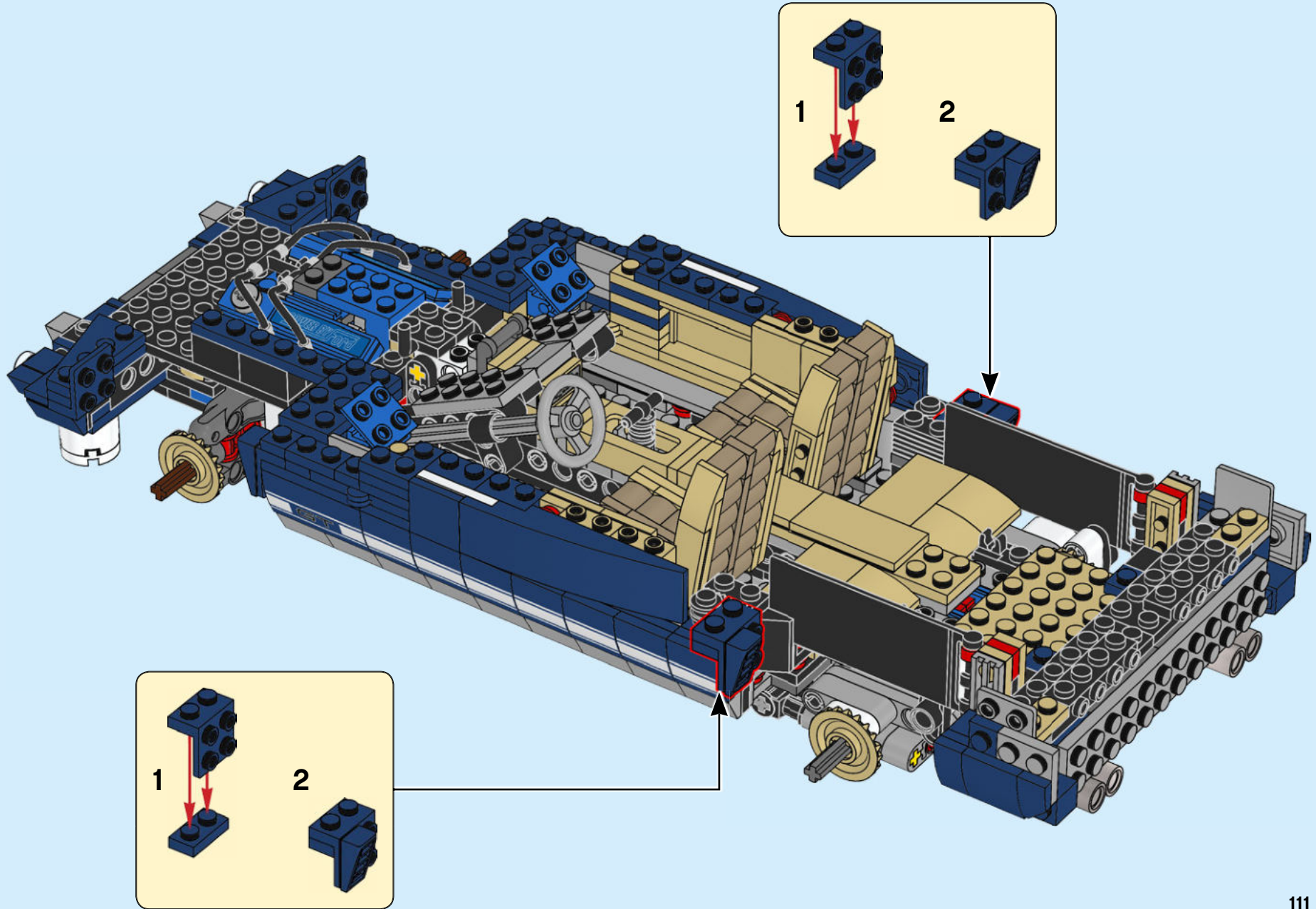

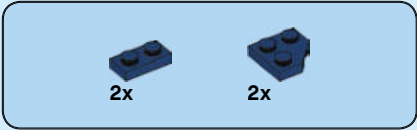

188

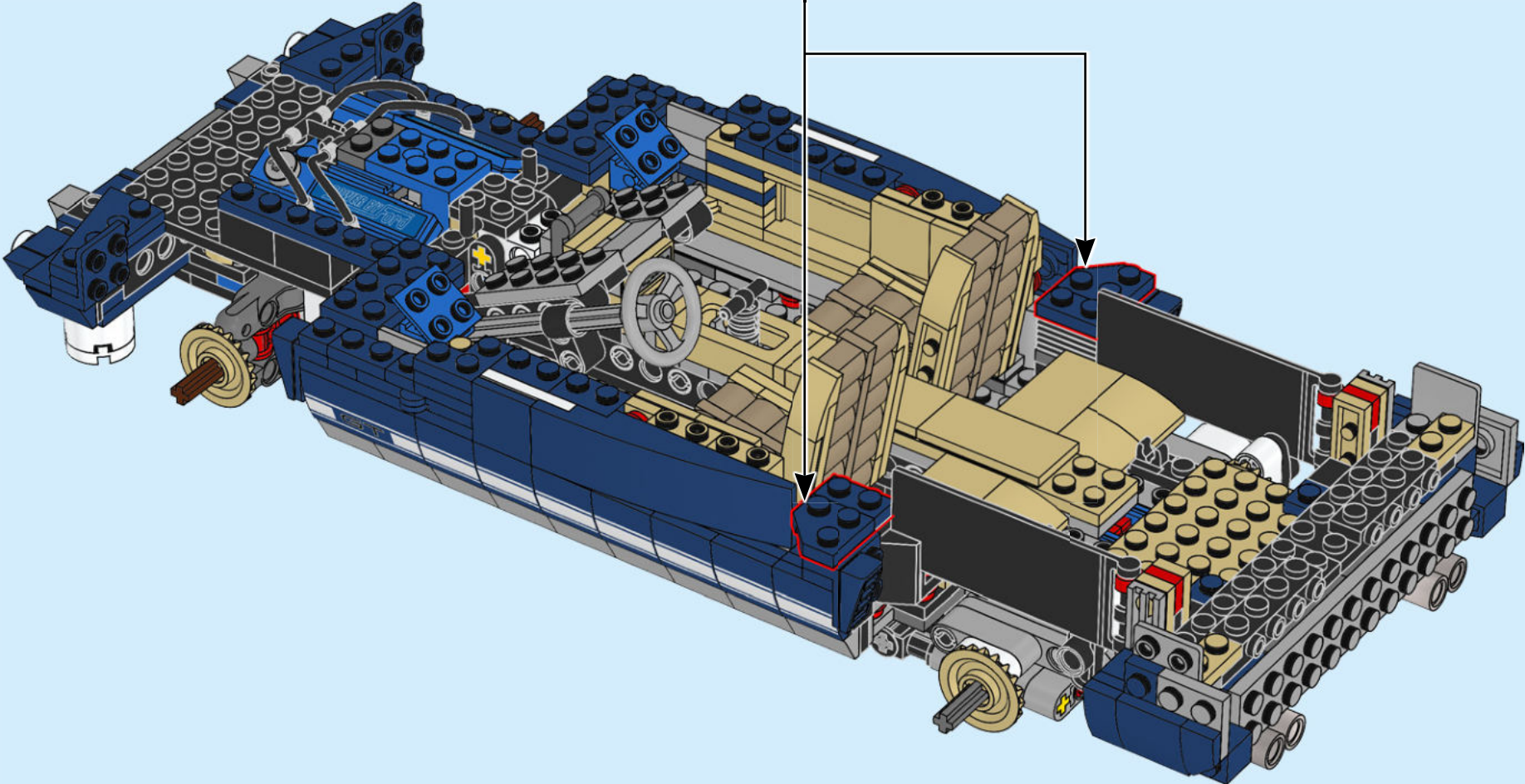

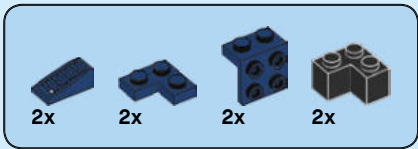

189

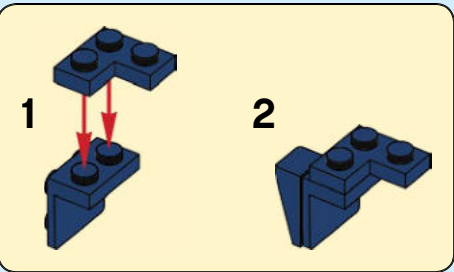
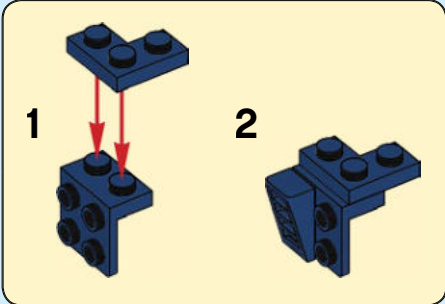
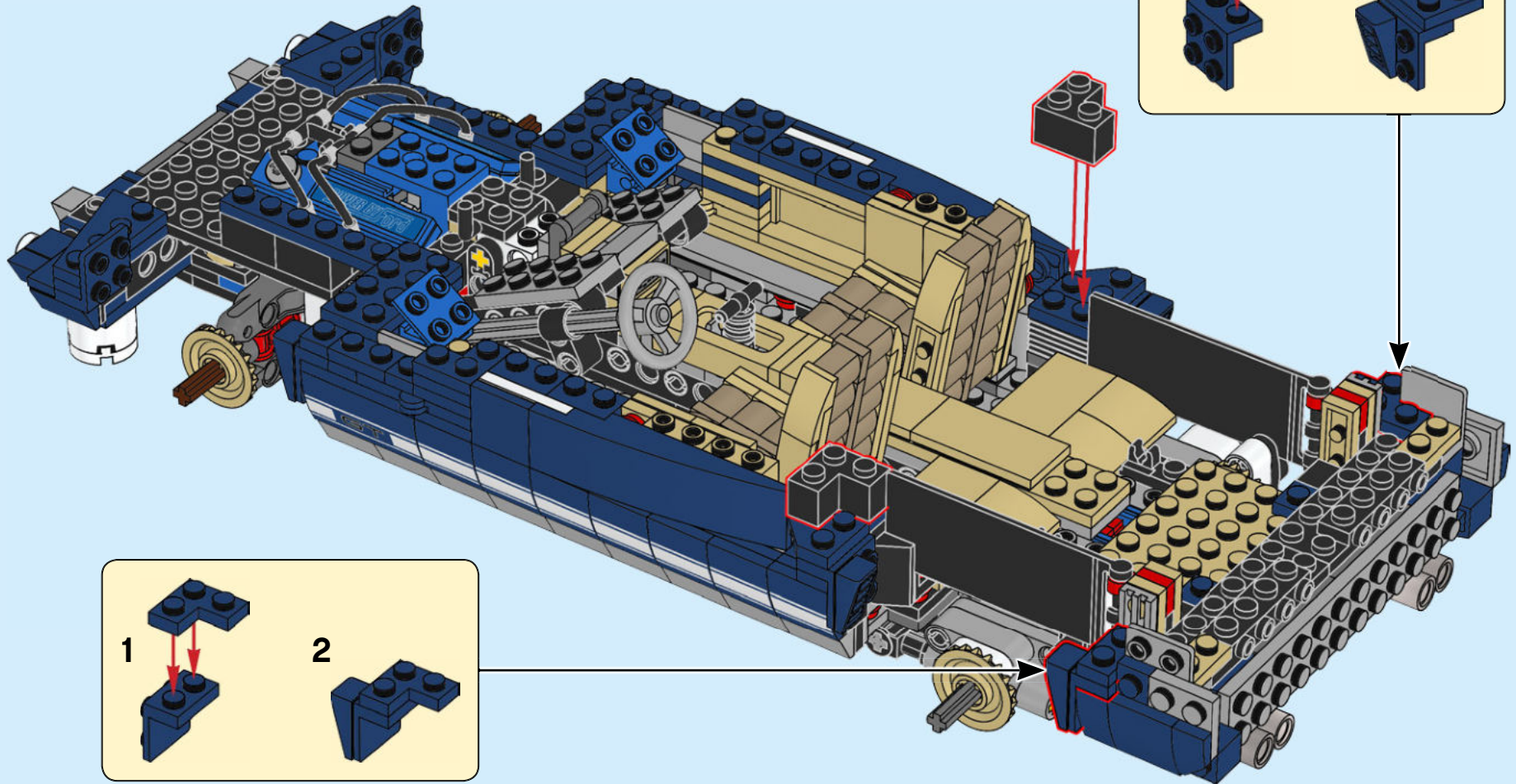

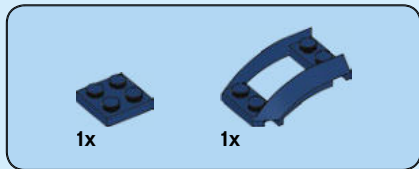

190

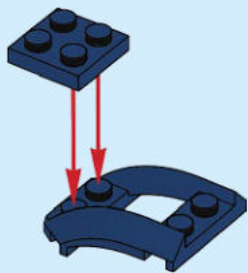

191

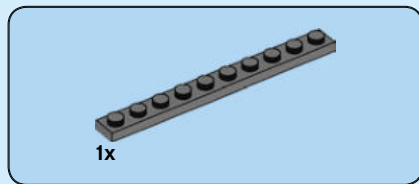

192

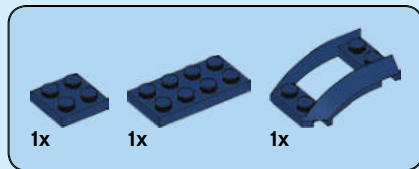
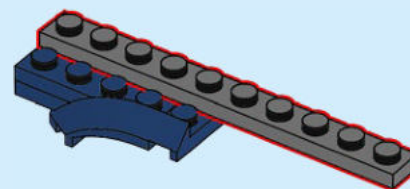

193

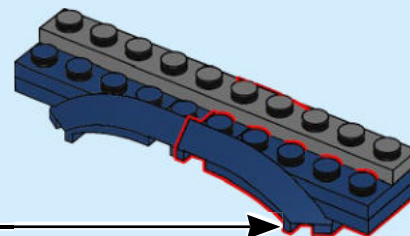
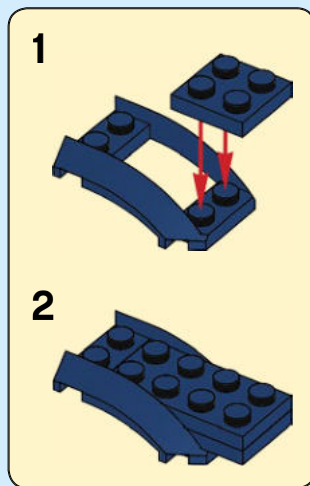

2x

194

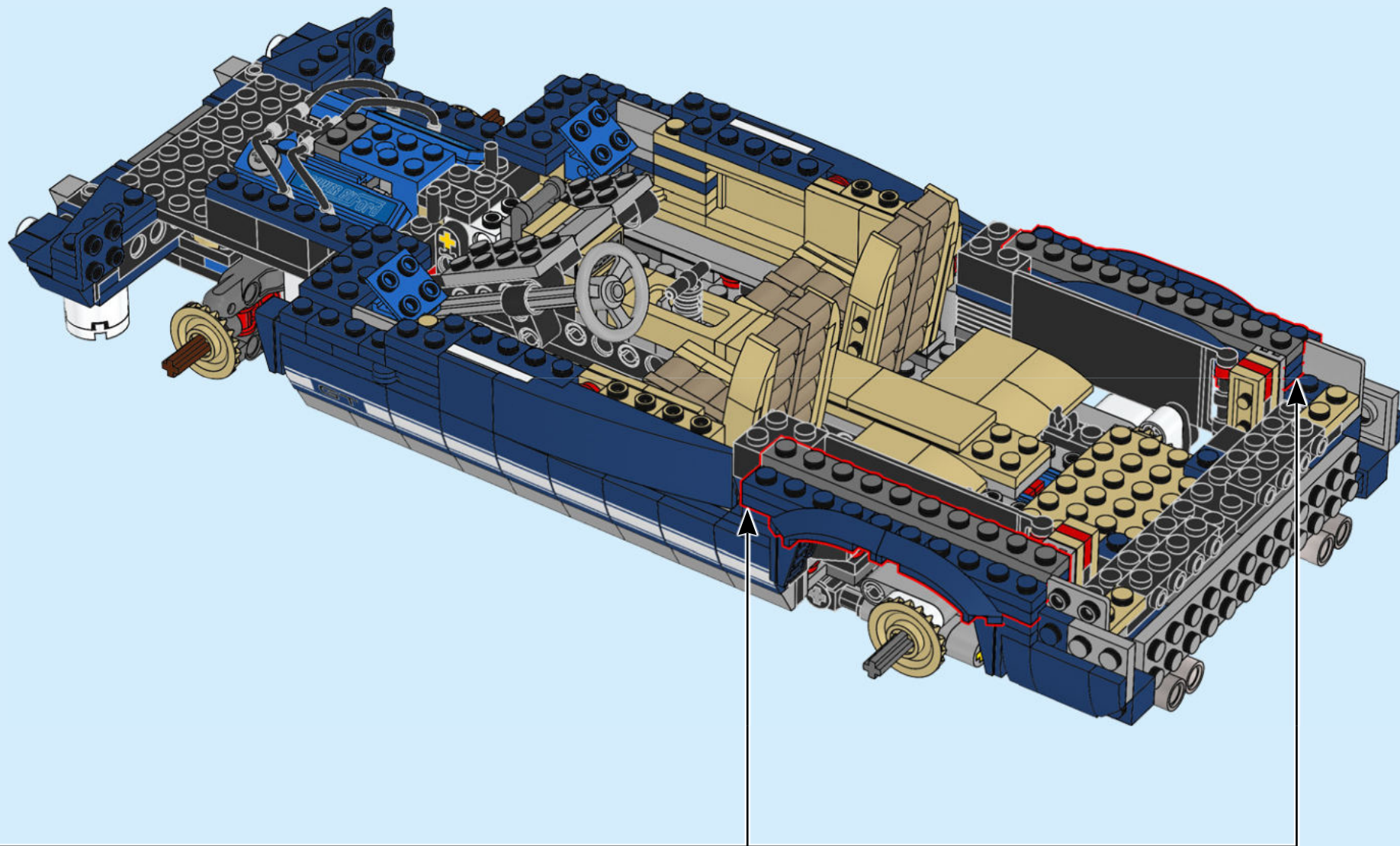

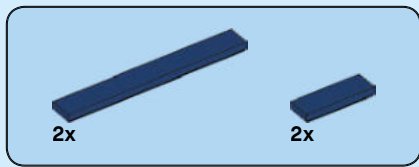

195

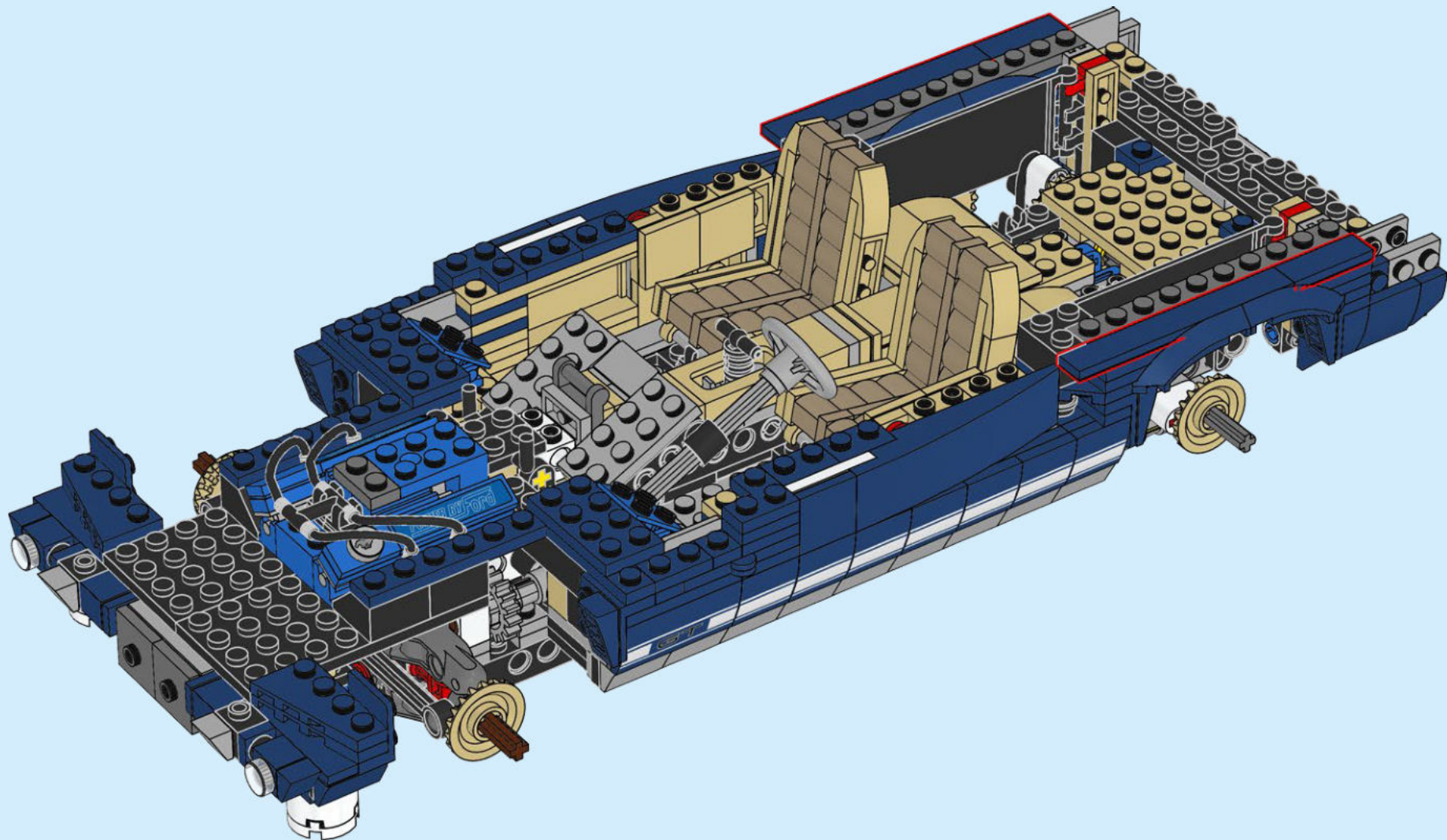

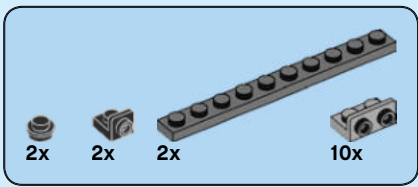

196

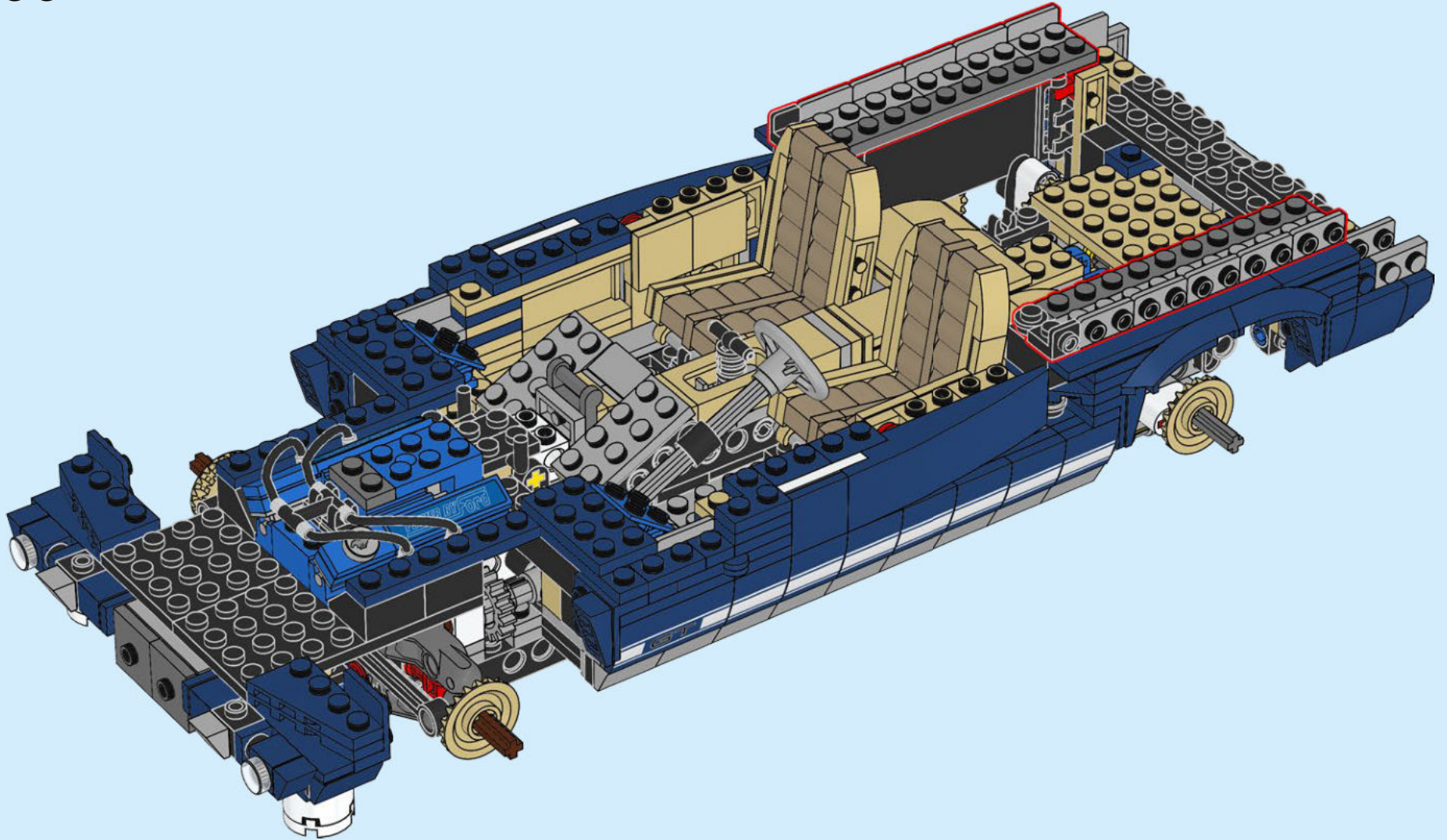

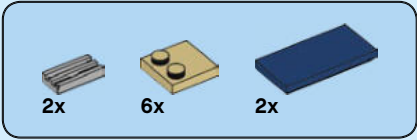

197

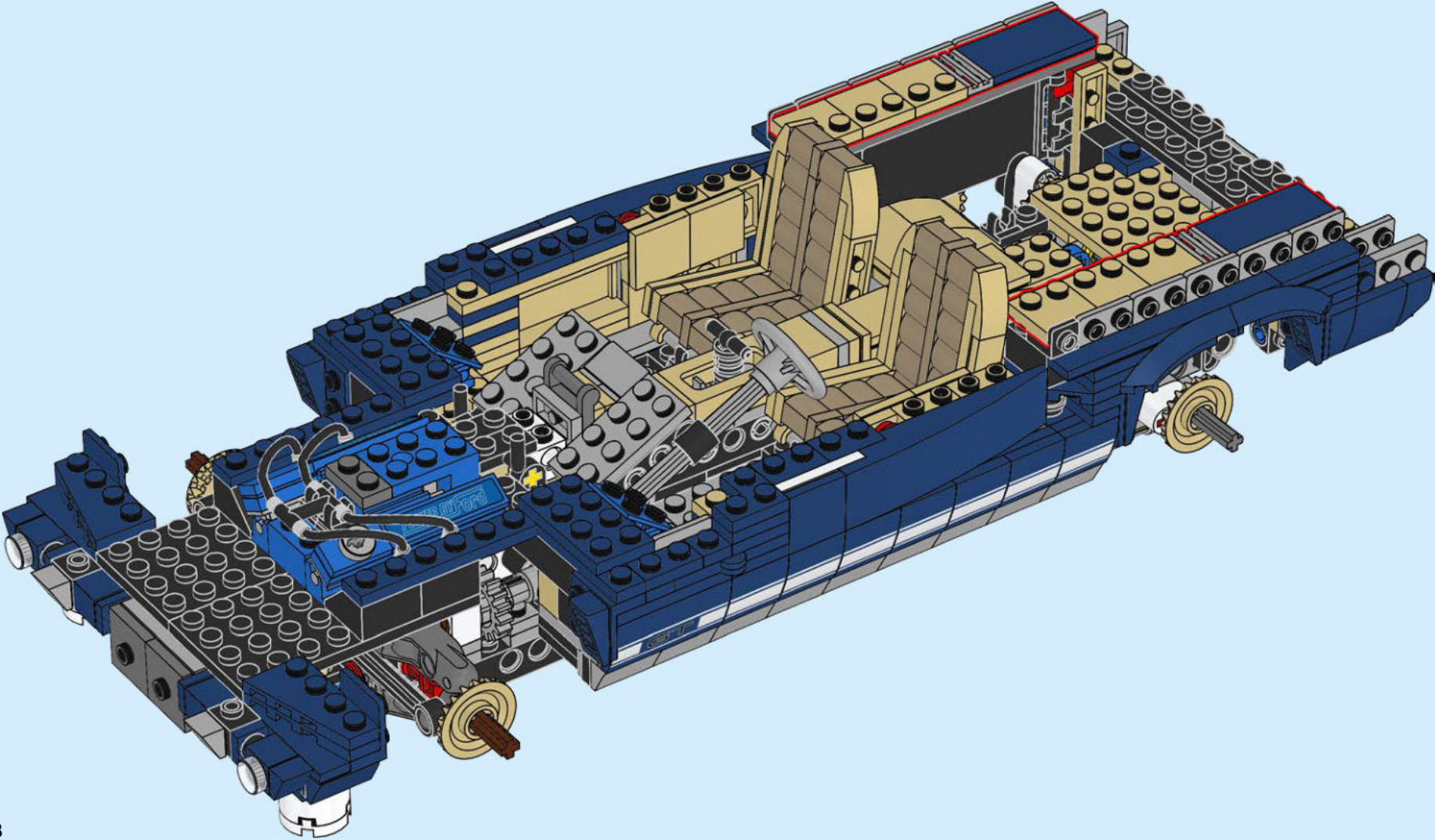

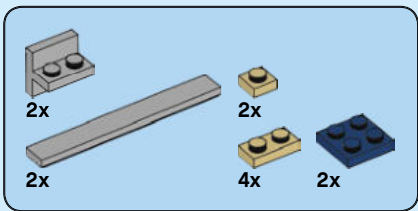

198

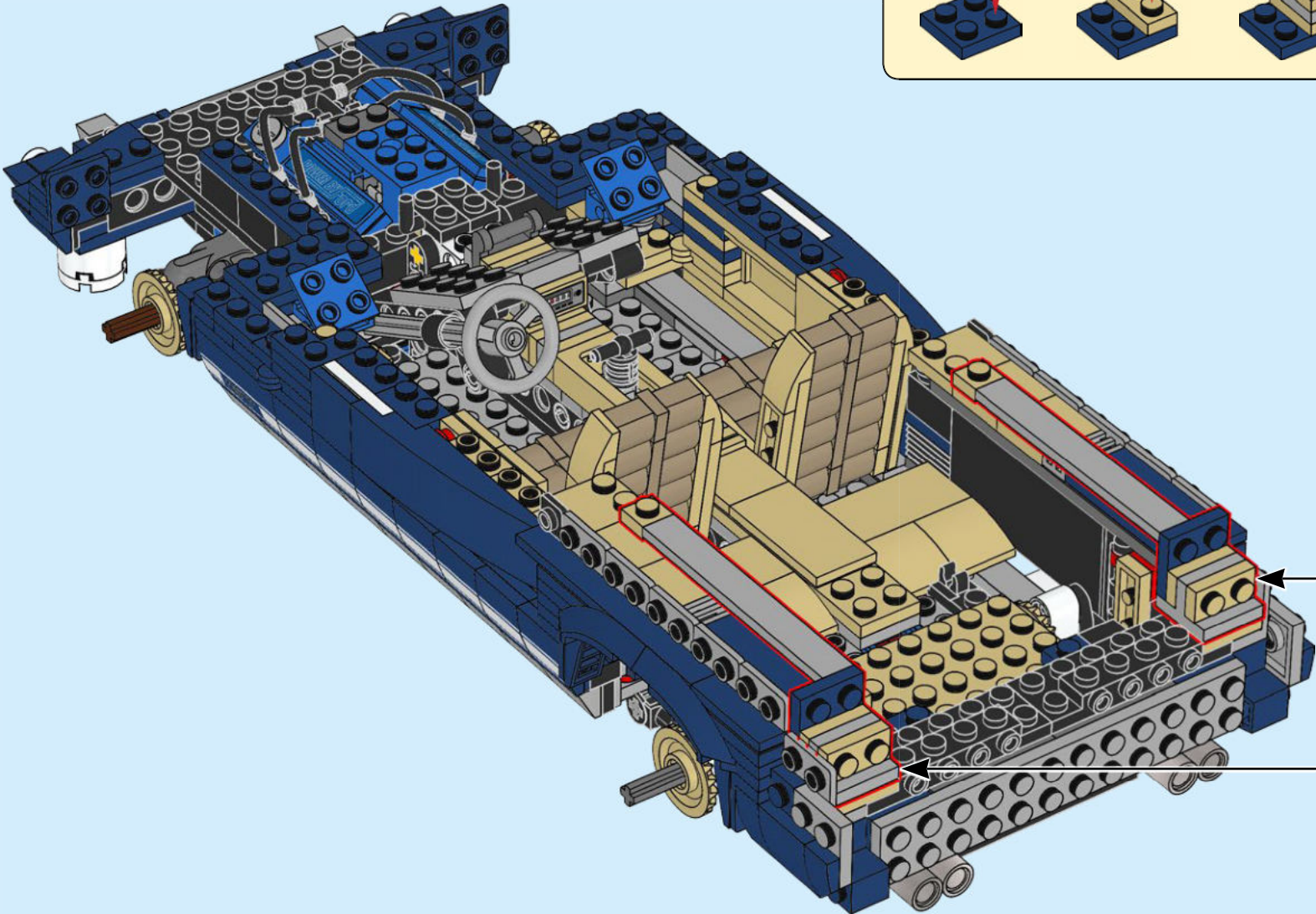
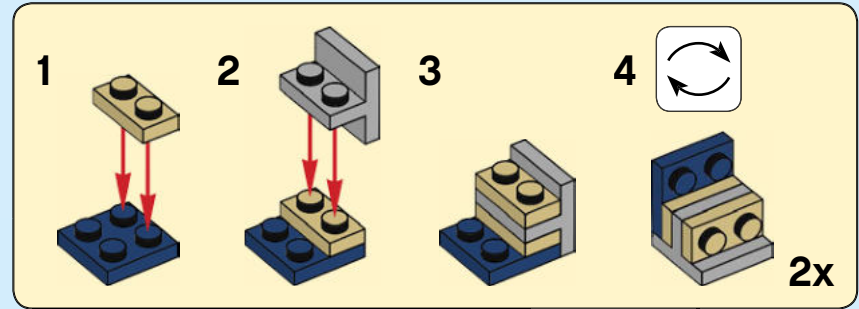

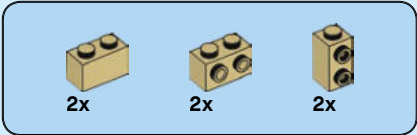

199

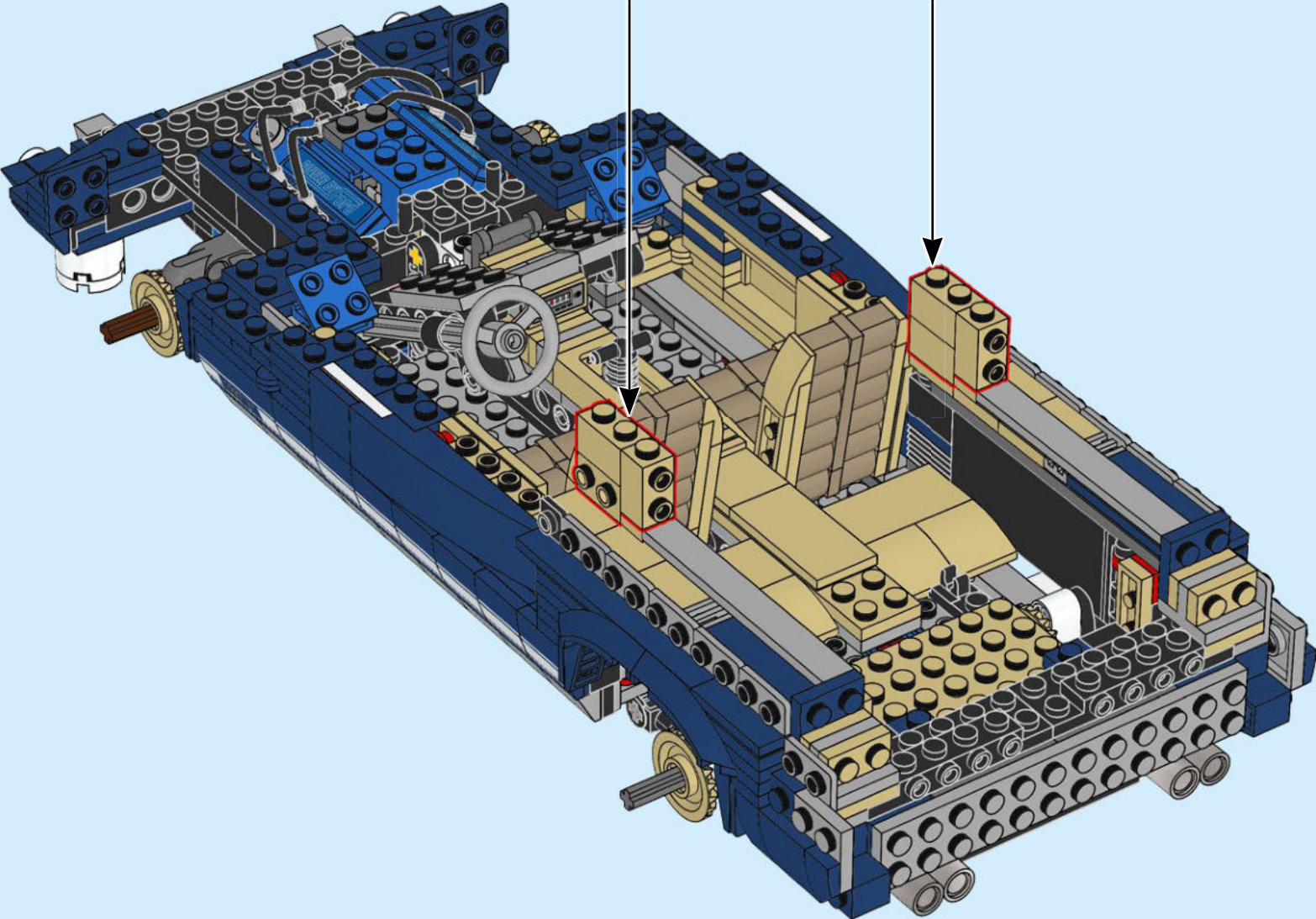
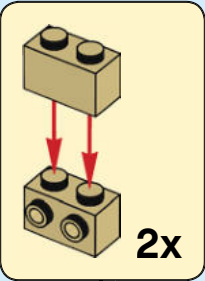

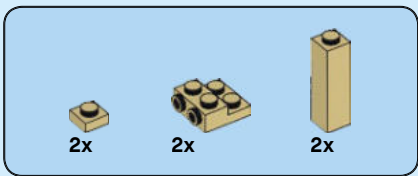

200



Ford's 300 millionth car was a special edition Mustang - a GT convertible.

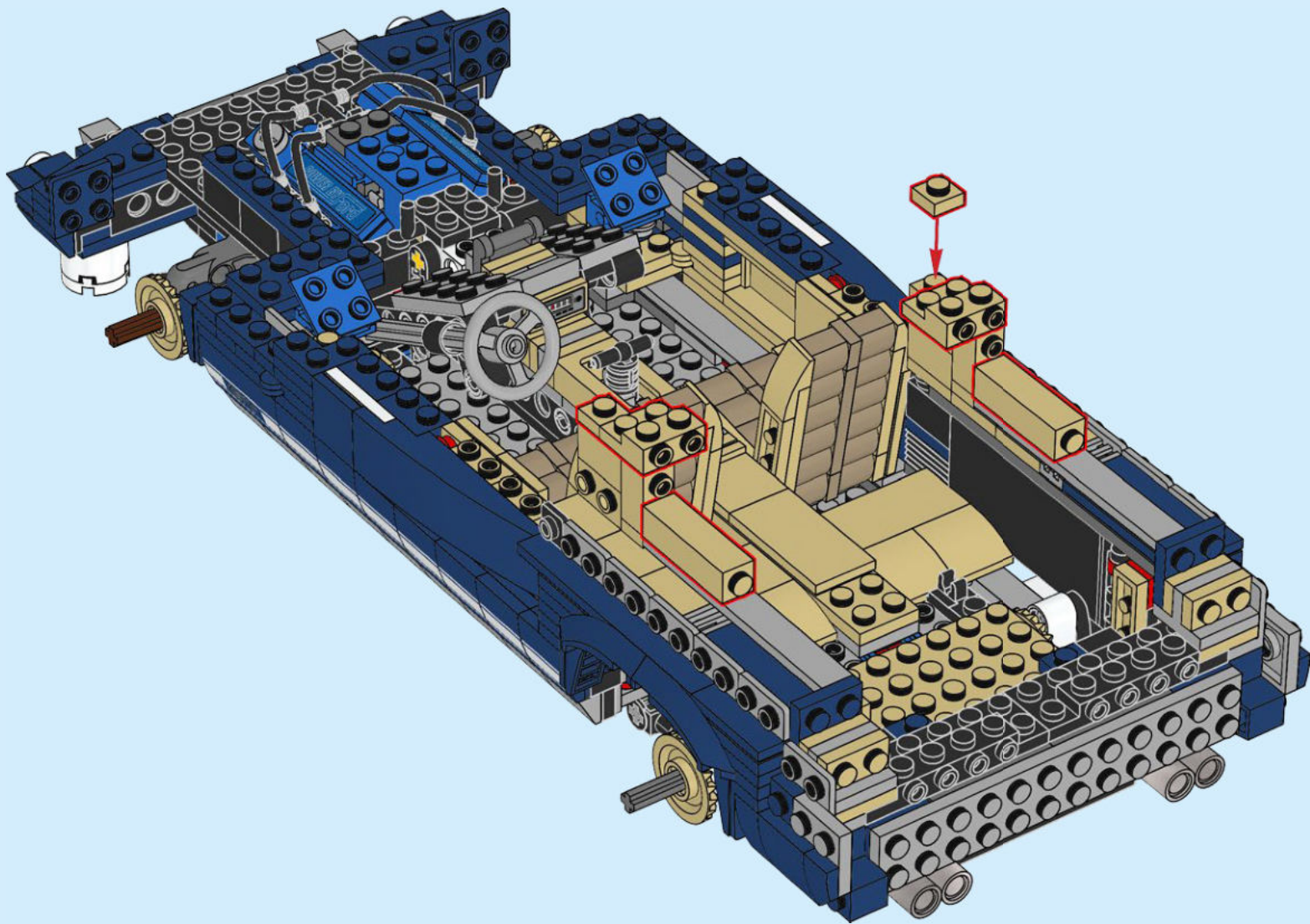

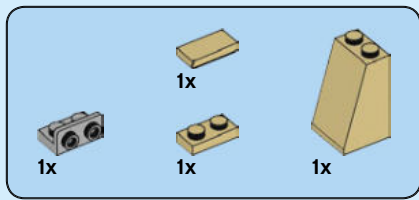

201

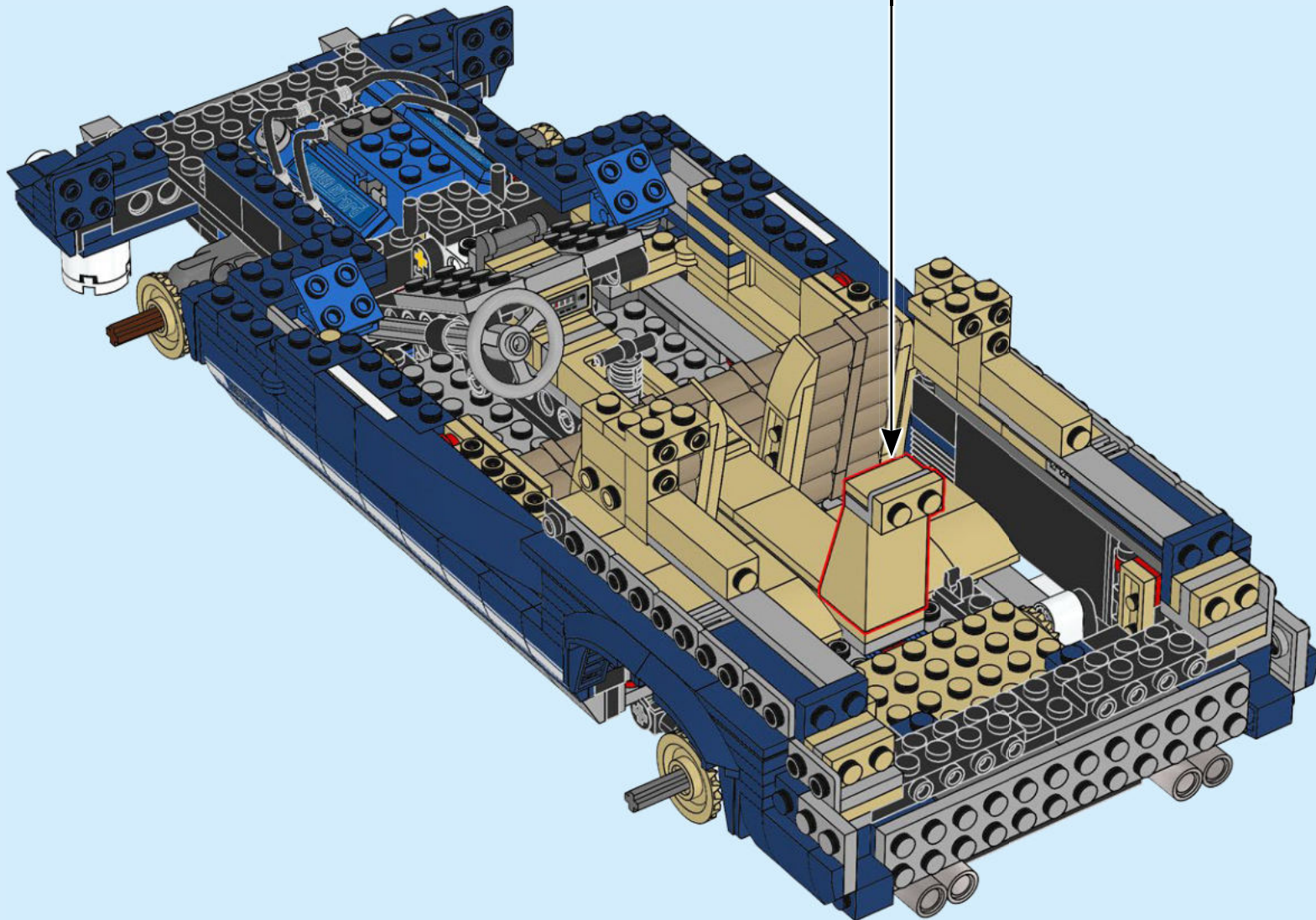
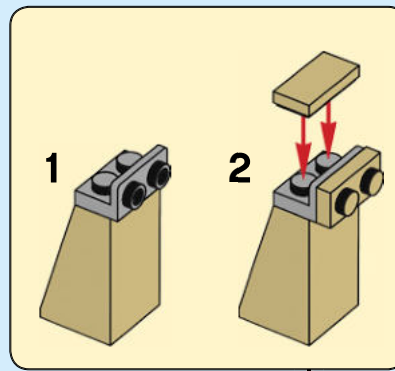

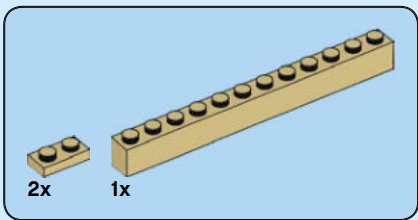

202

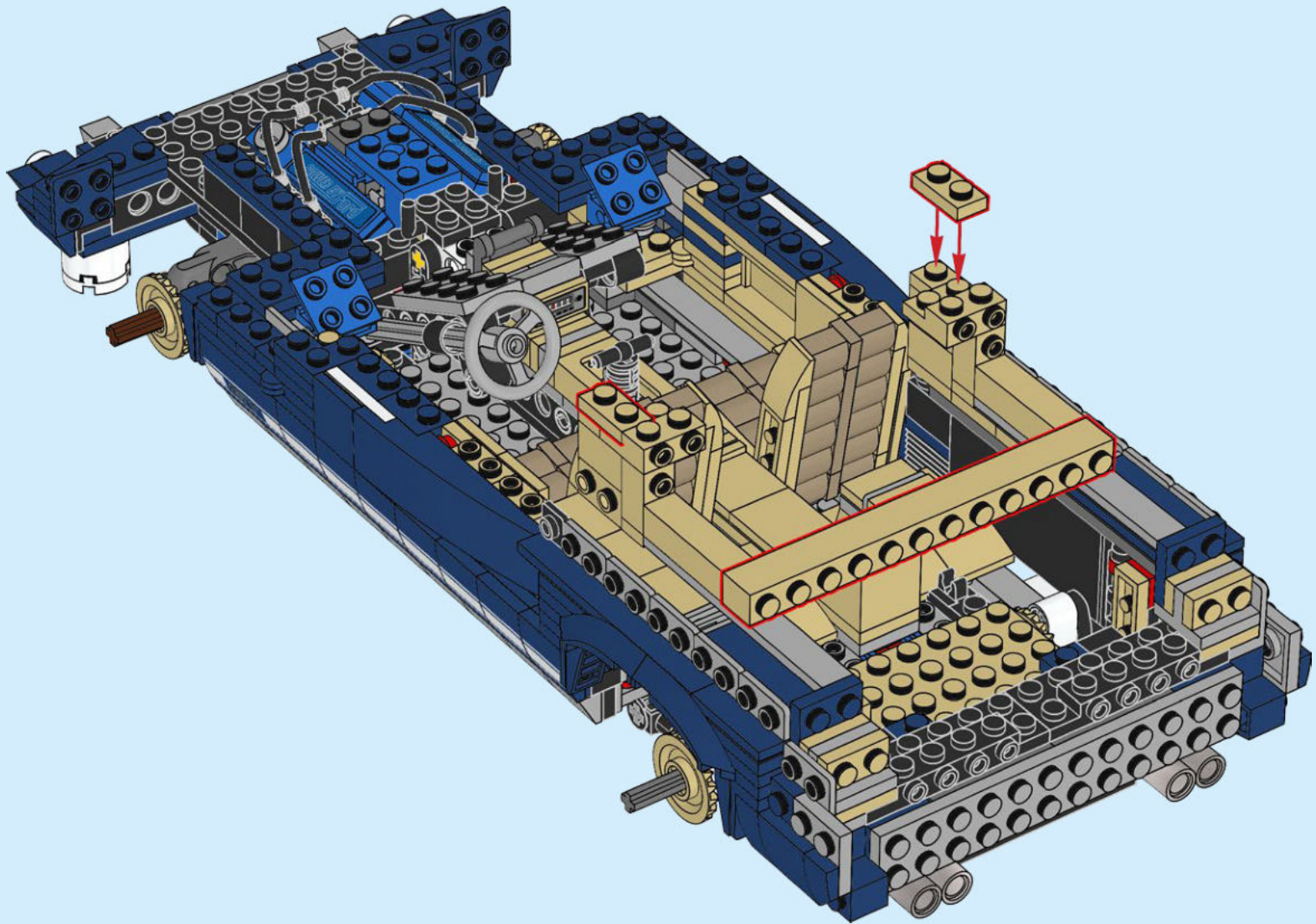

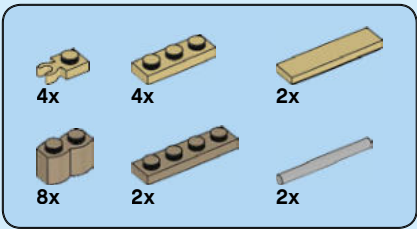

203

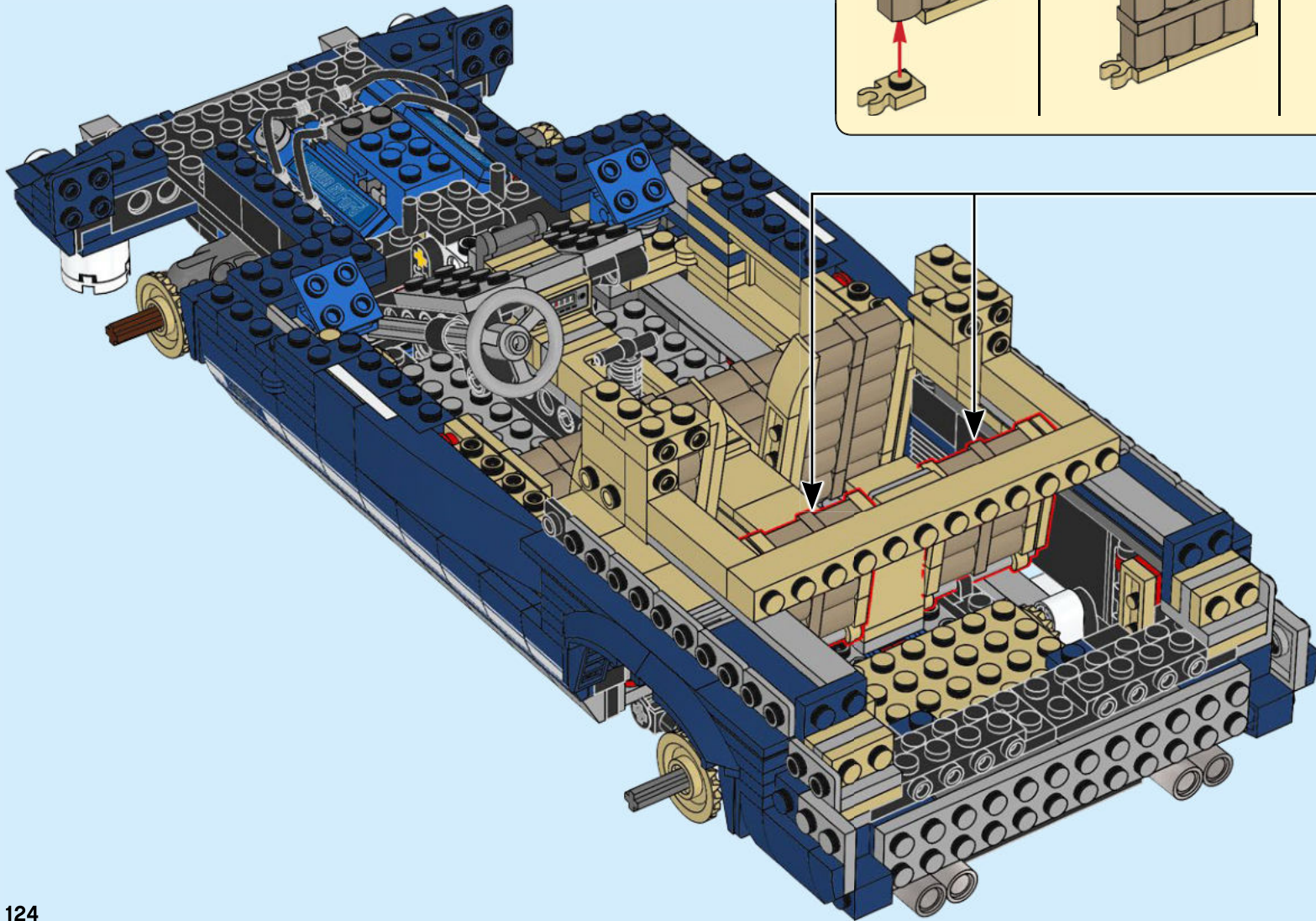
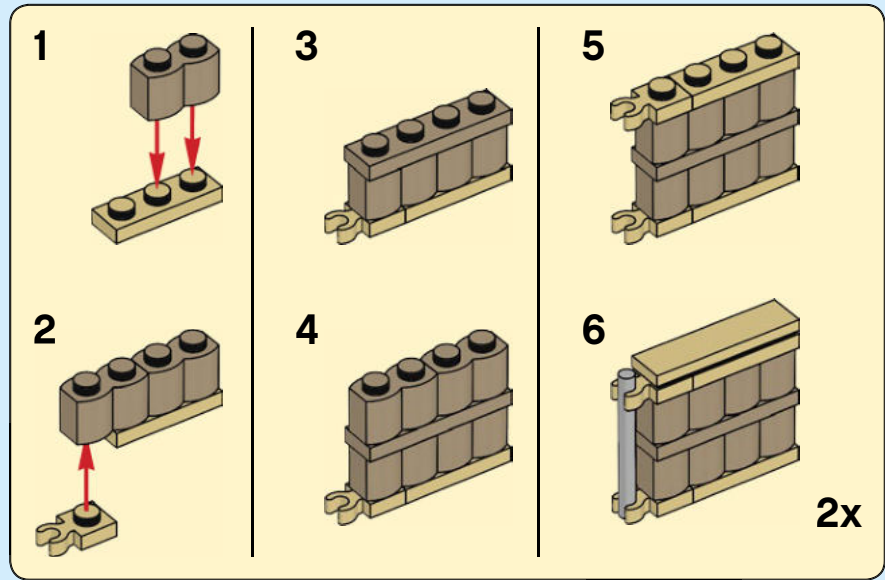

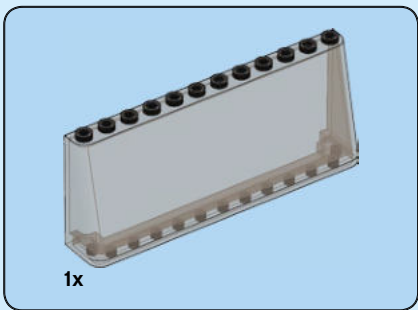

204

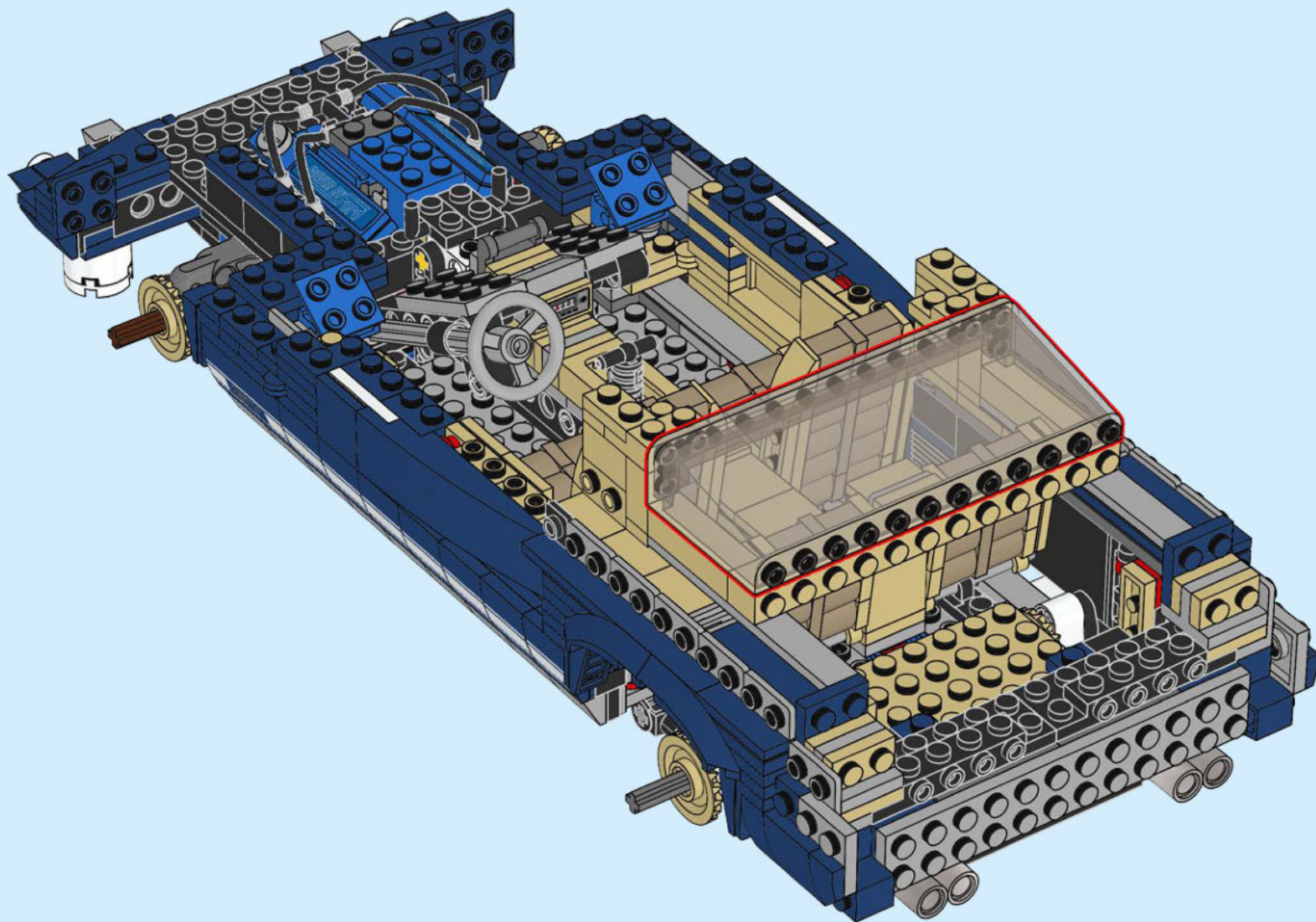



205

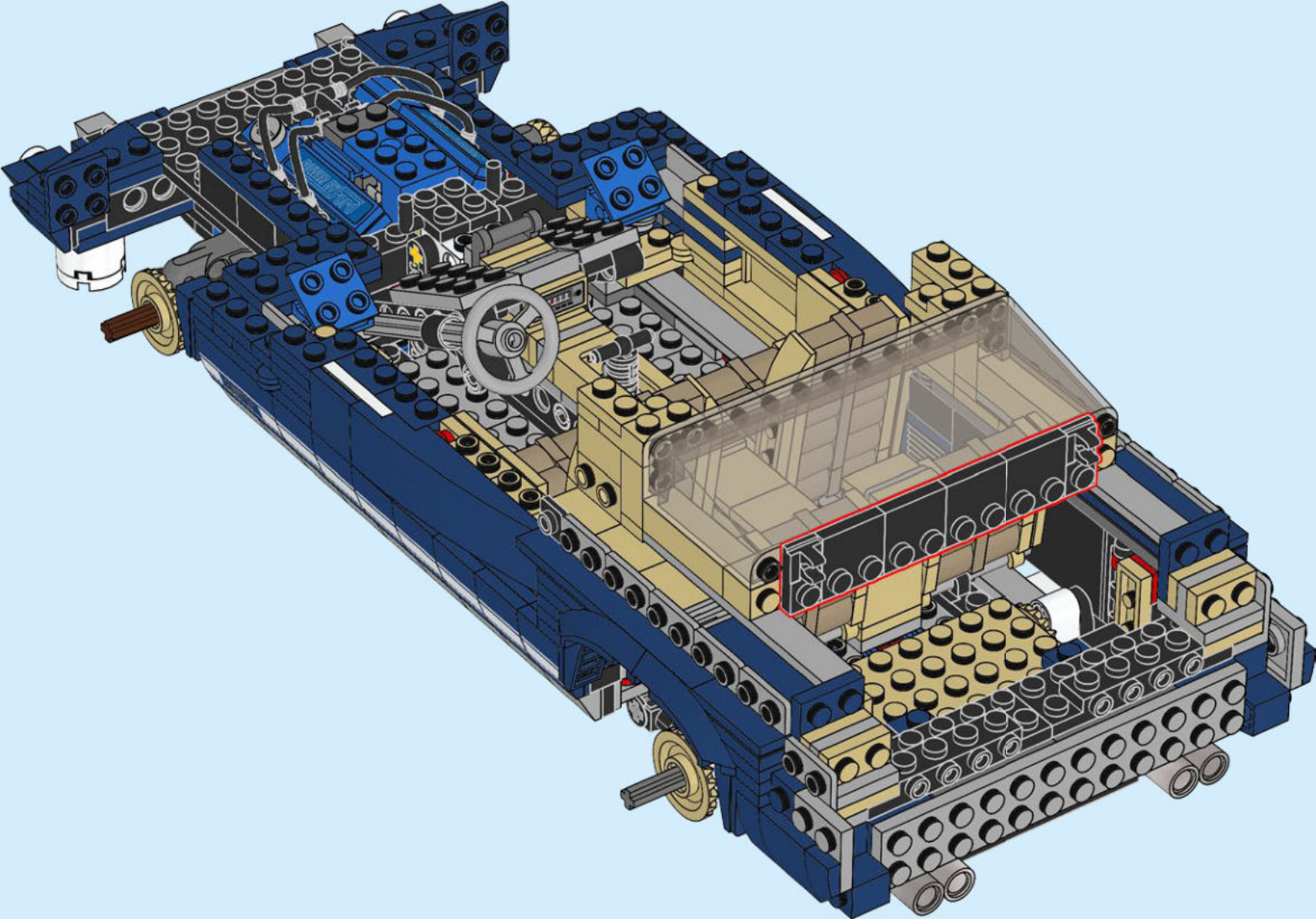

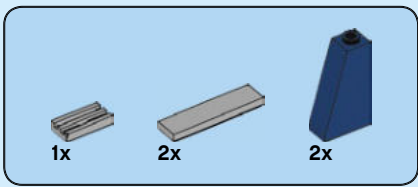

206

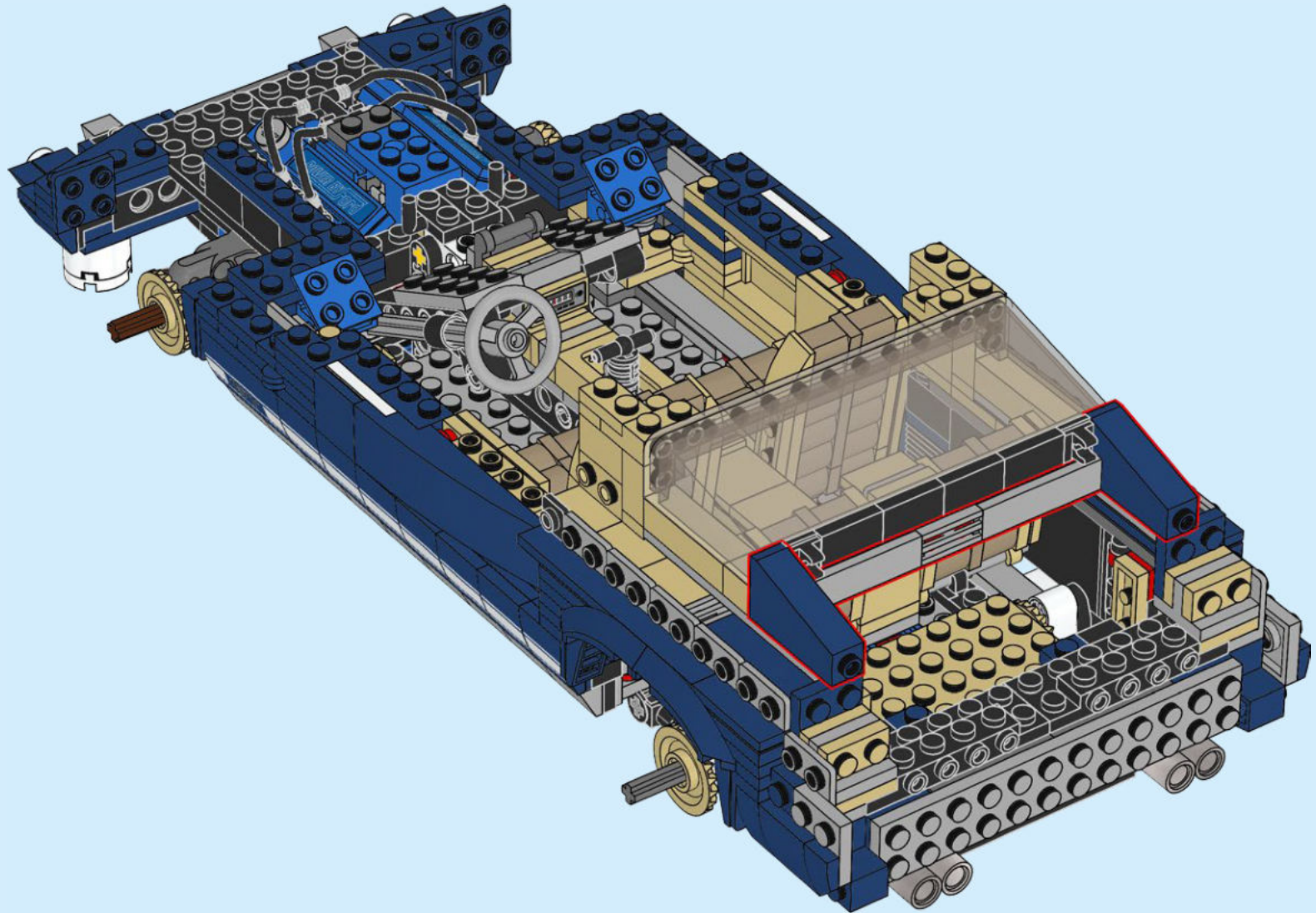

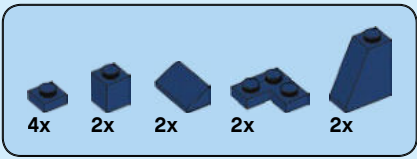

207

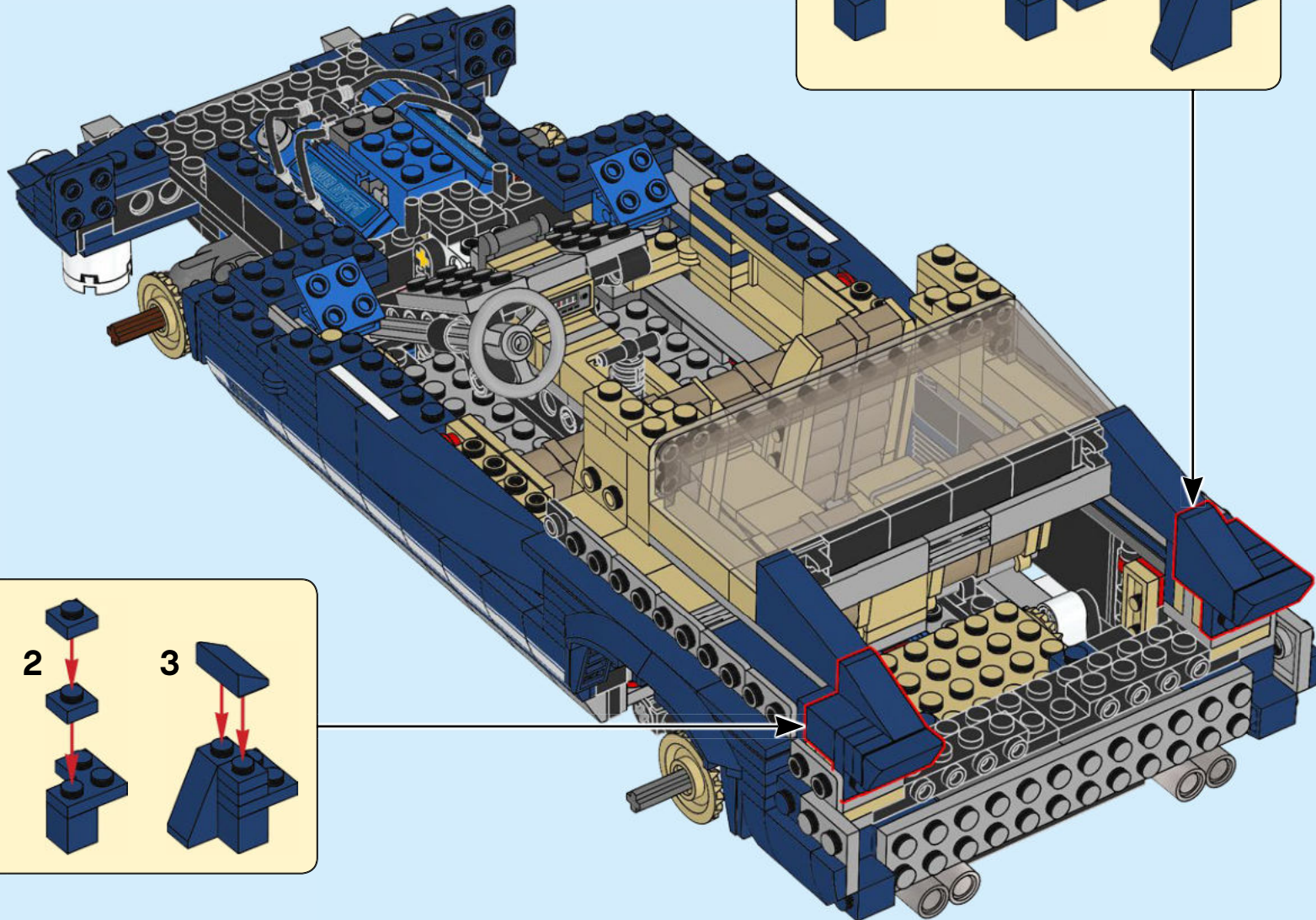
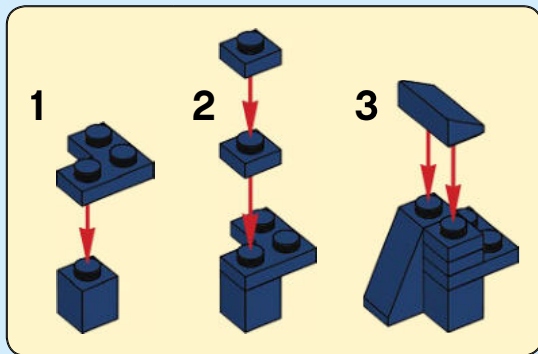
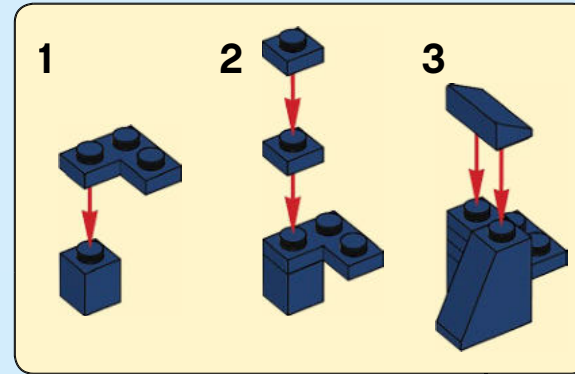

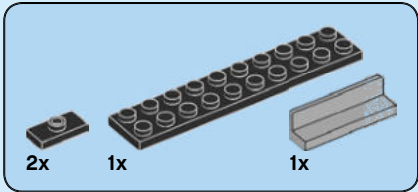
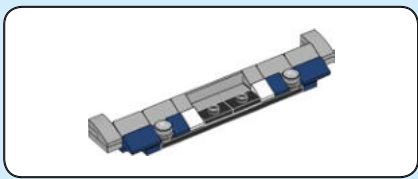

208

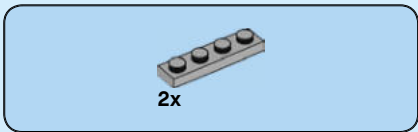
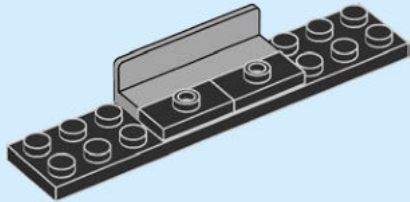

209

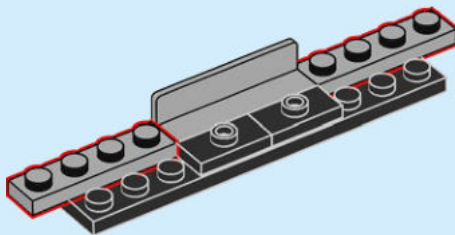

210

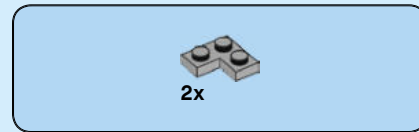
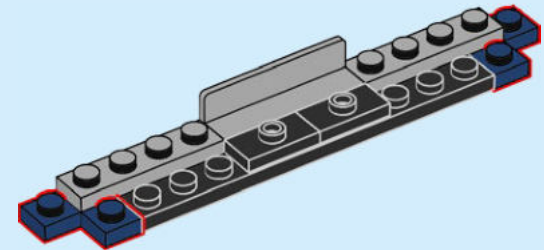

211

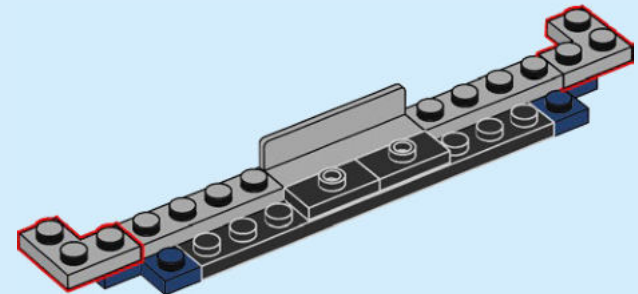

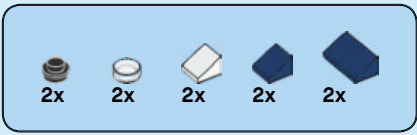

212

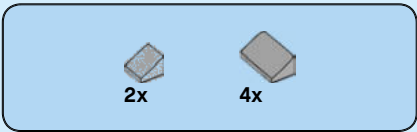
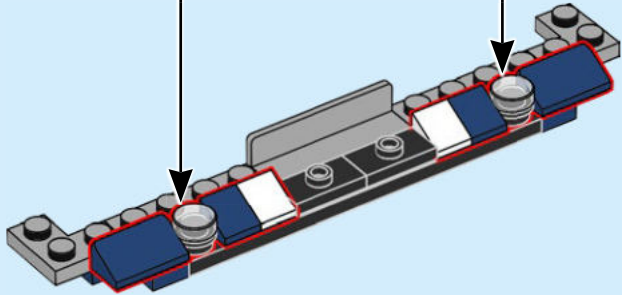
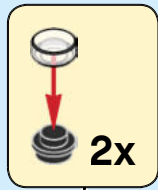

213

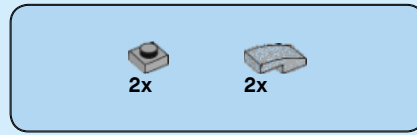
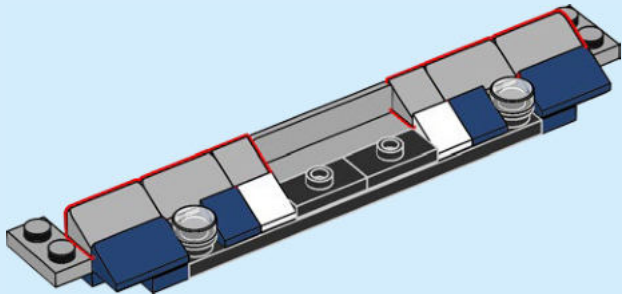

214

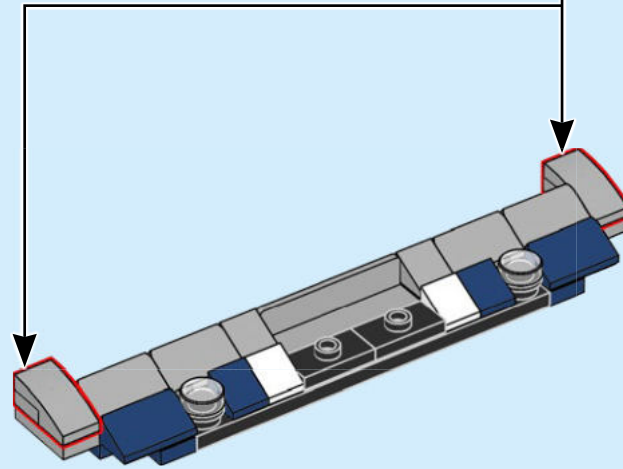
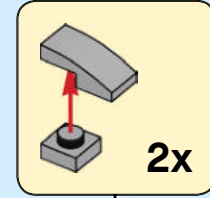

215

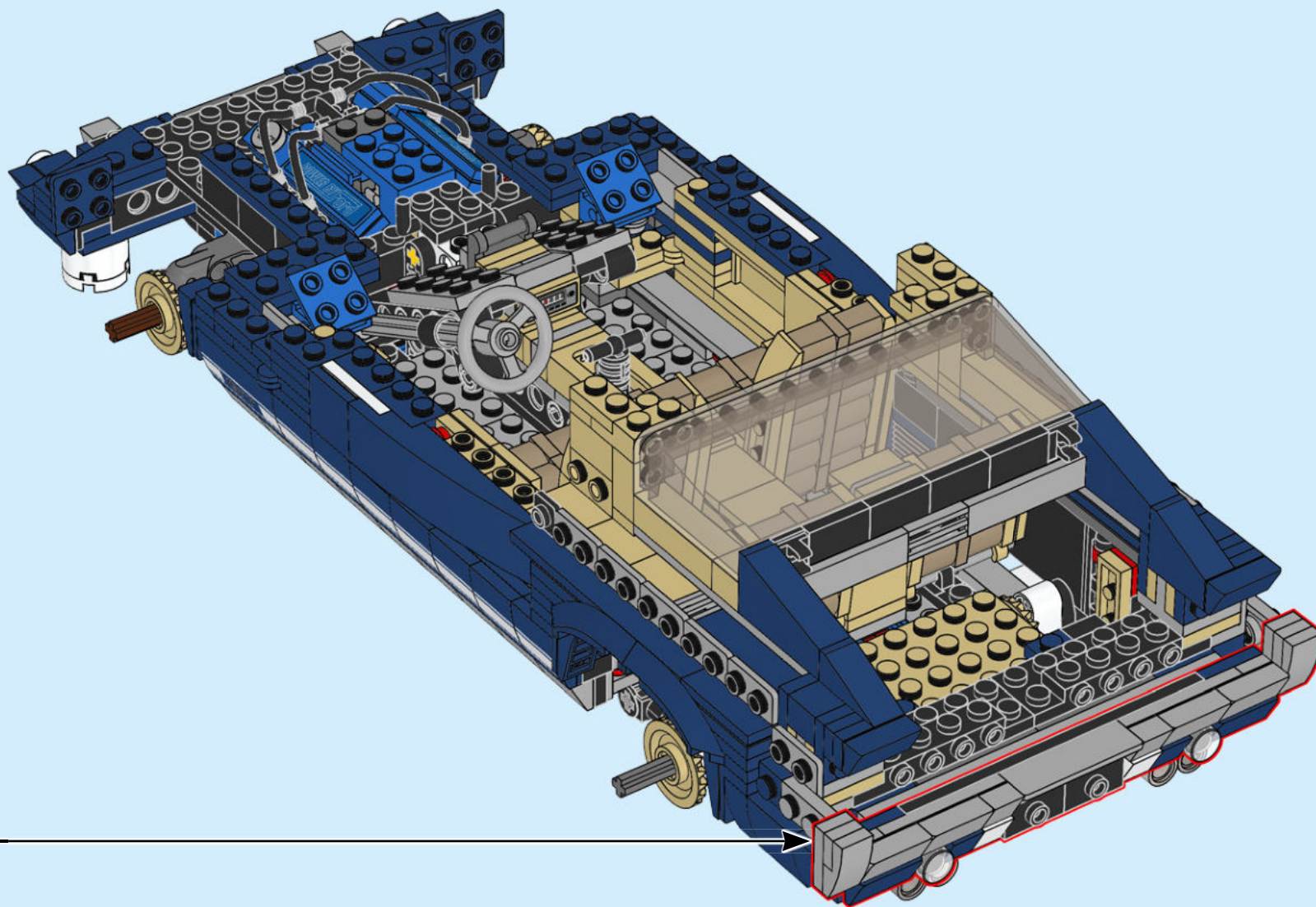

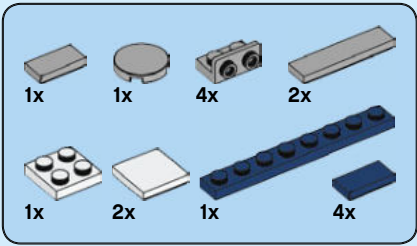

216

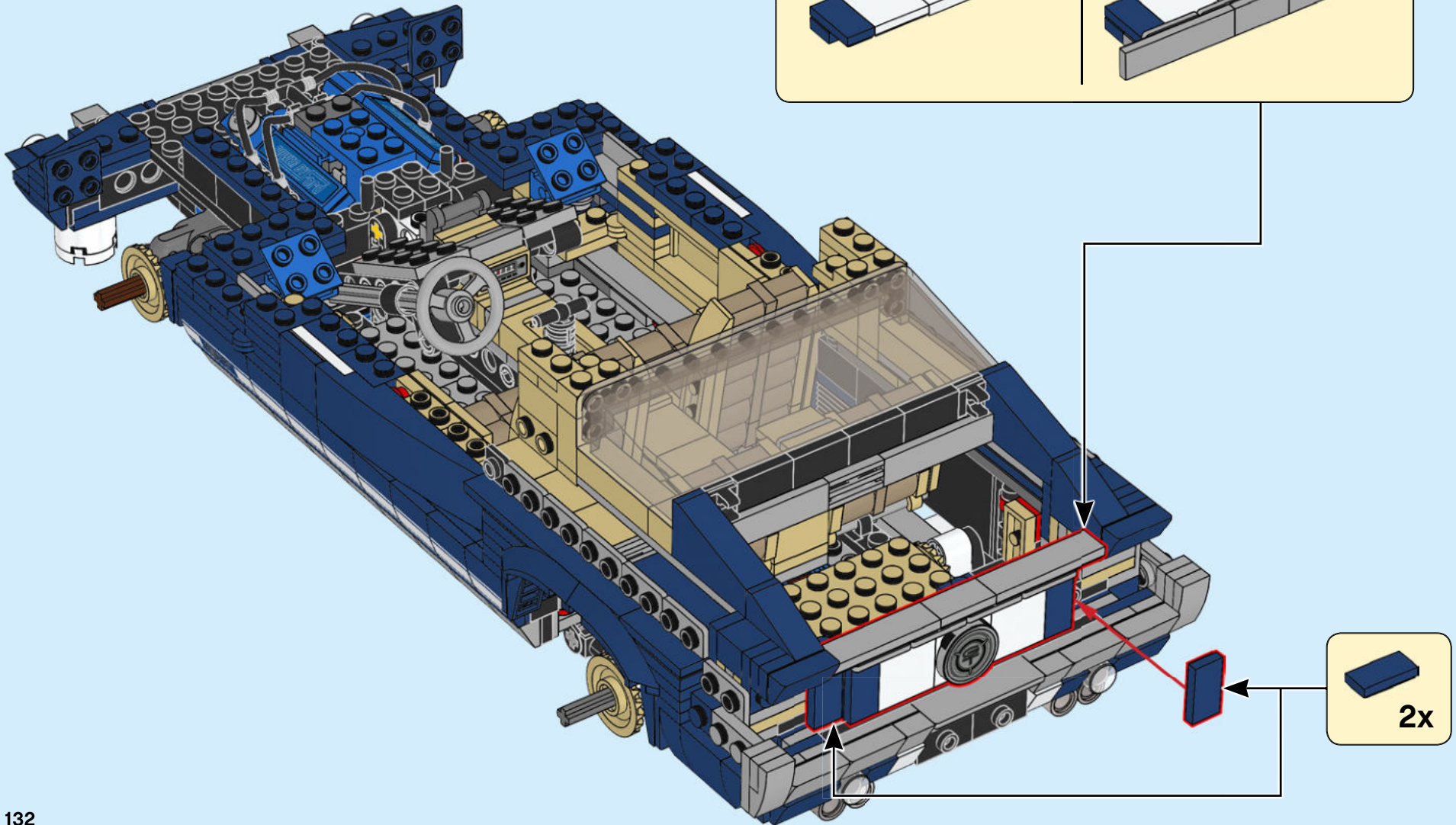
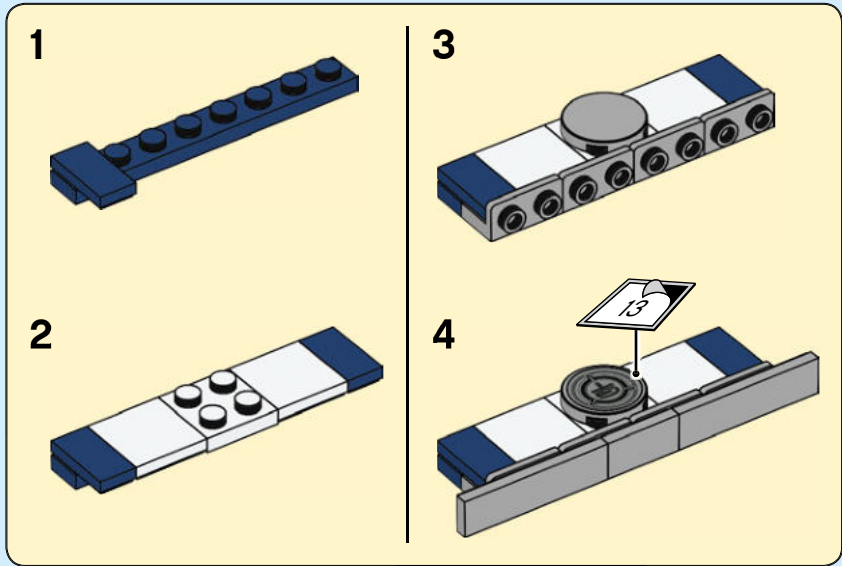

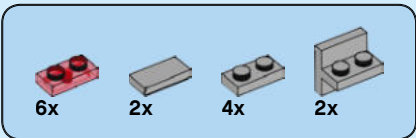

217

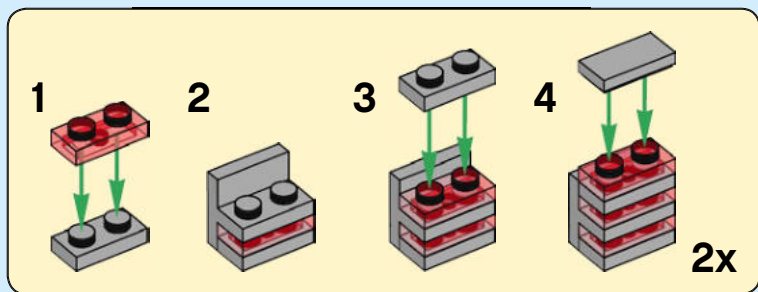
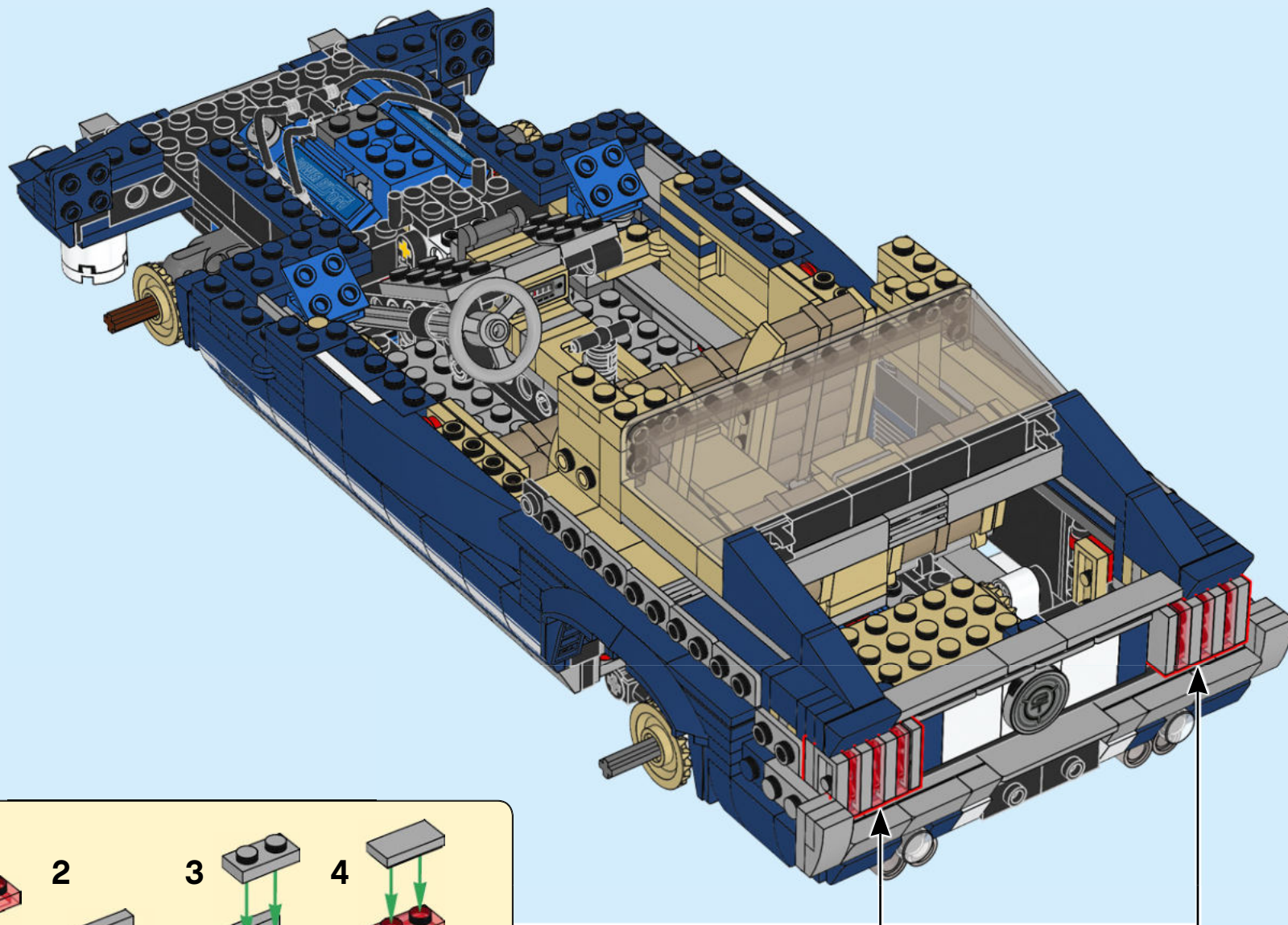

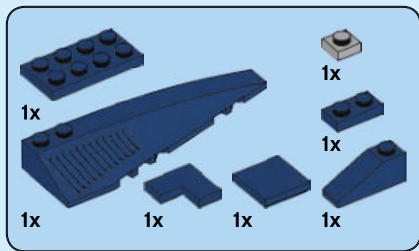

218

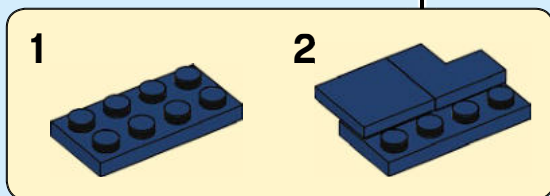
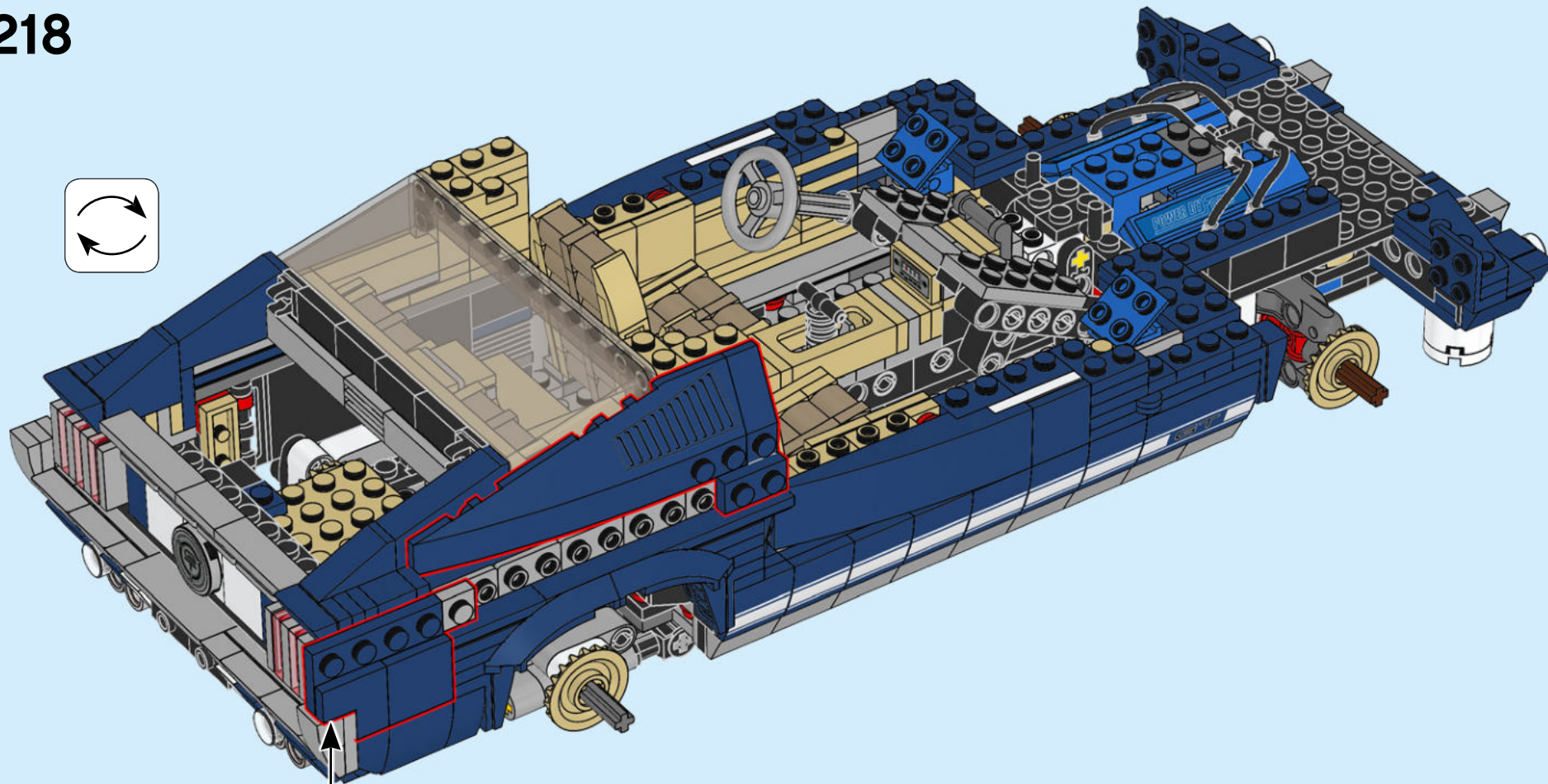

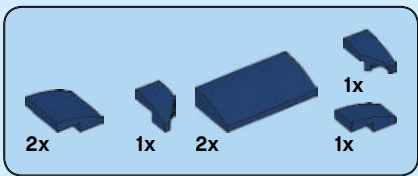

219

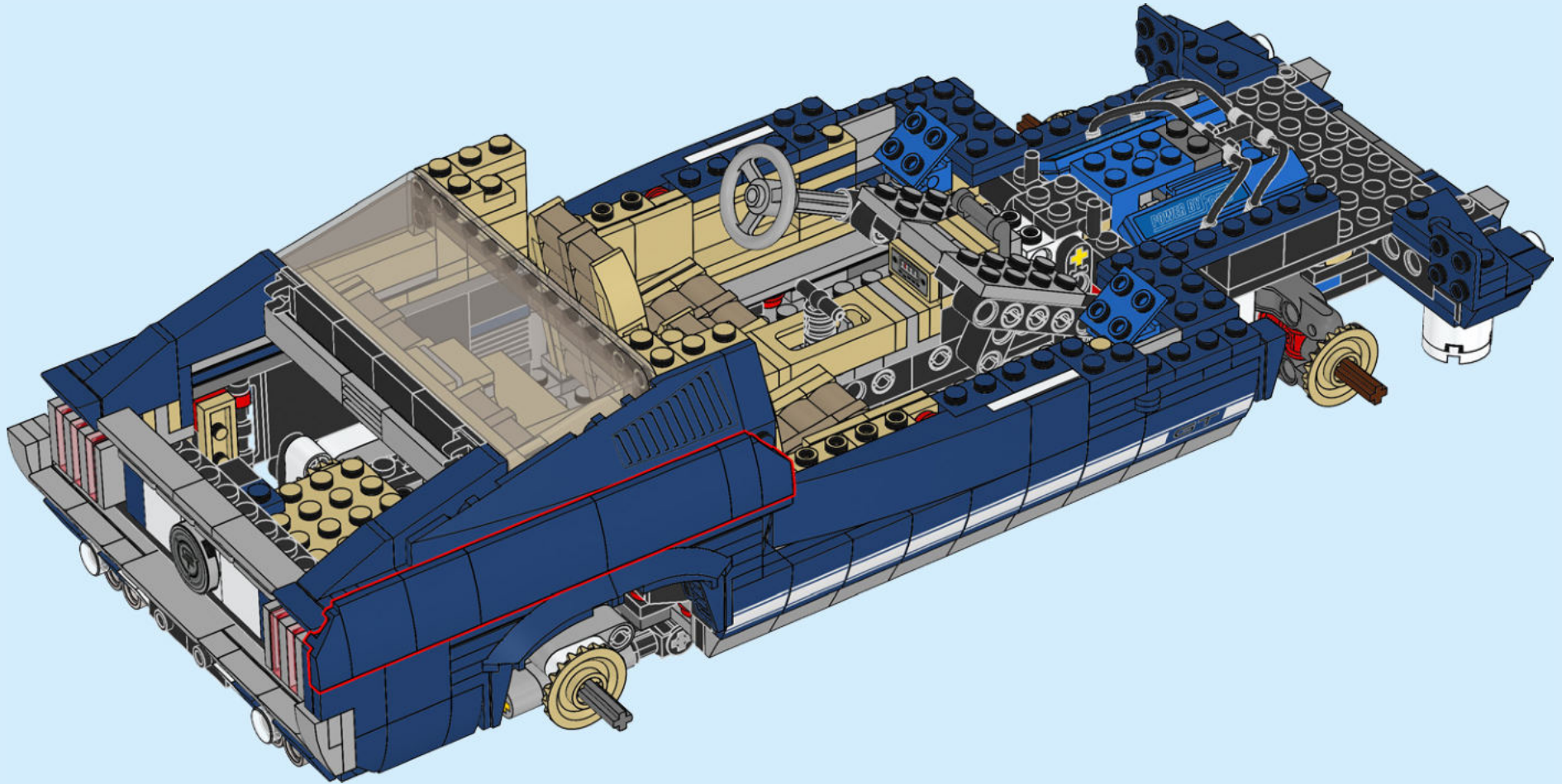

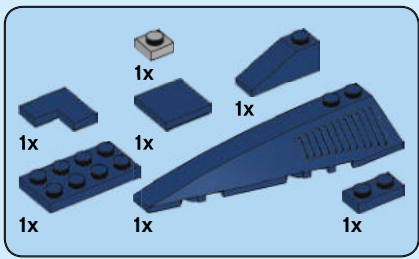

220

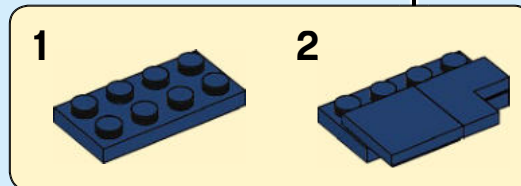
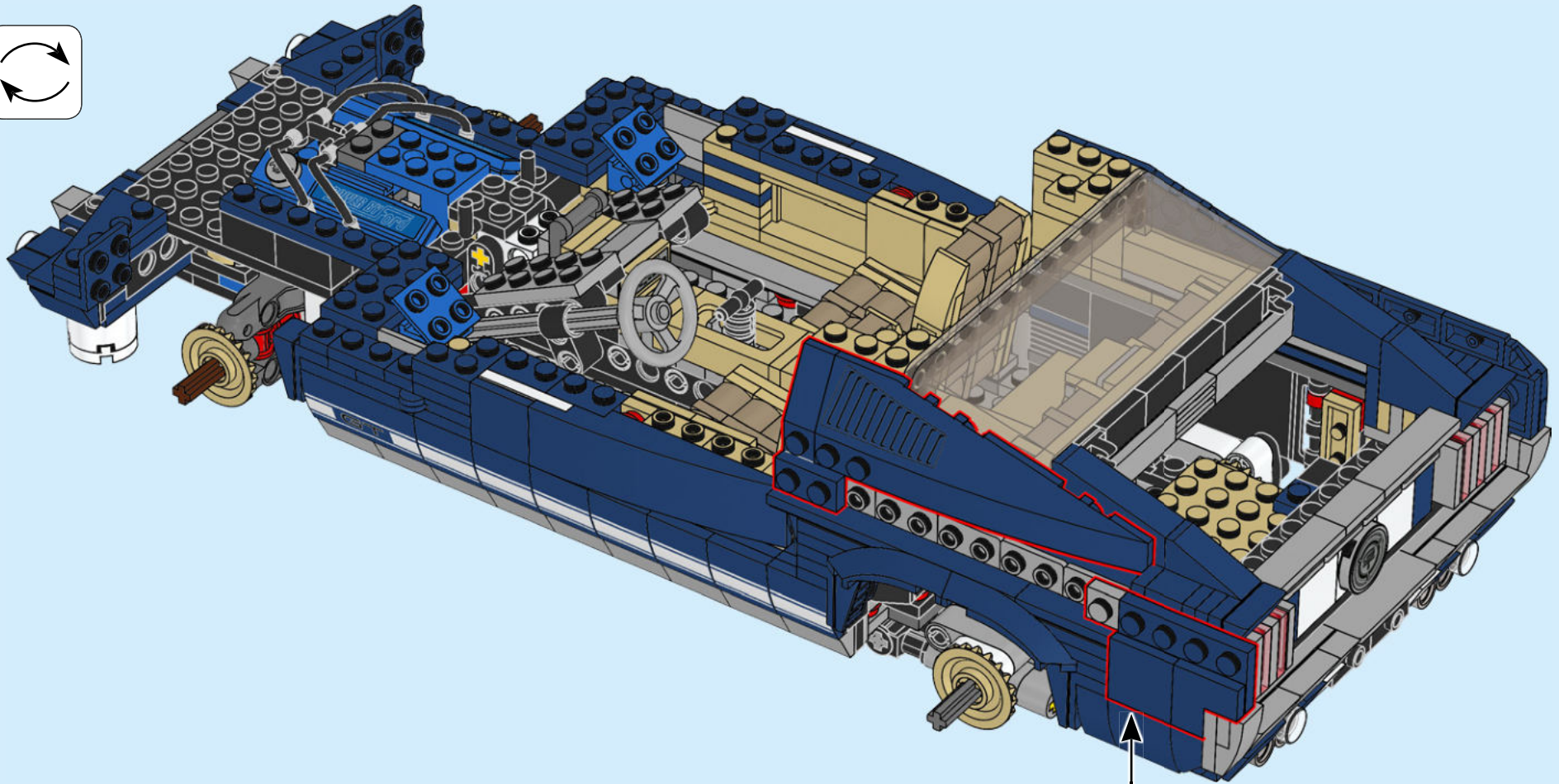
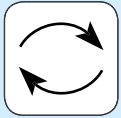

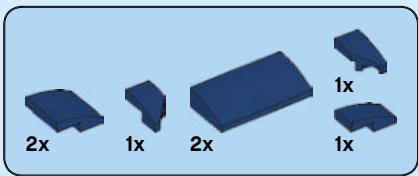

221

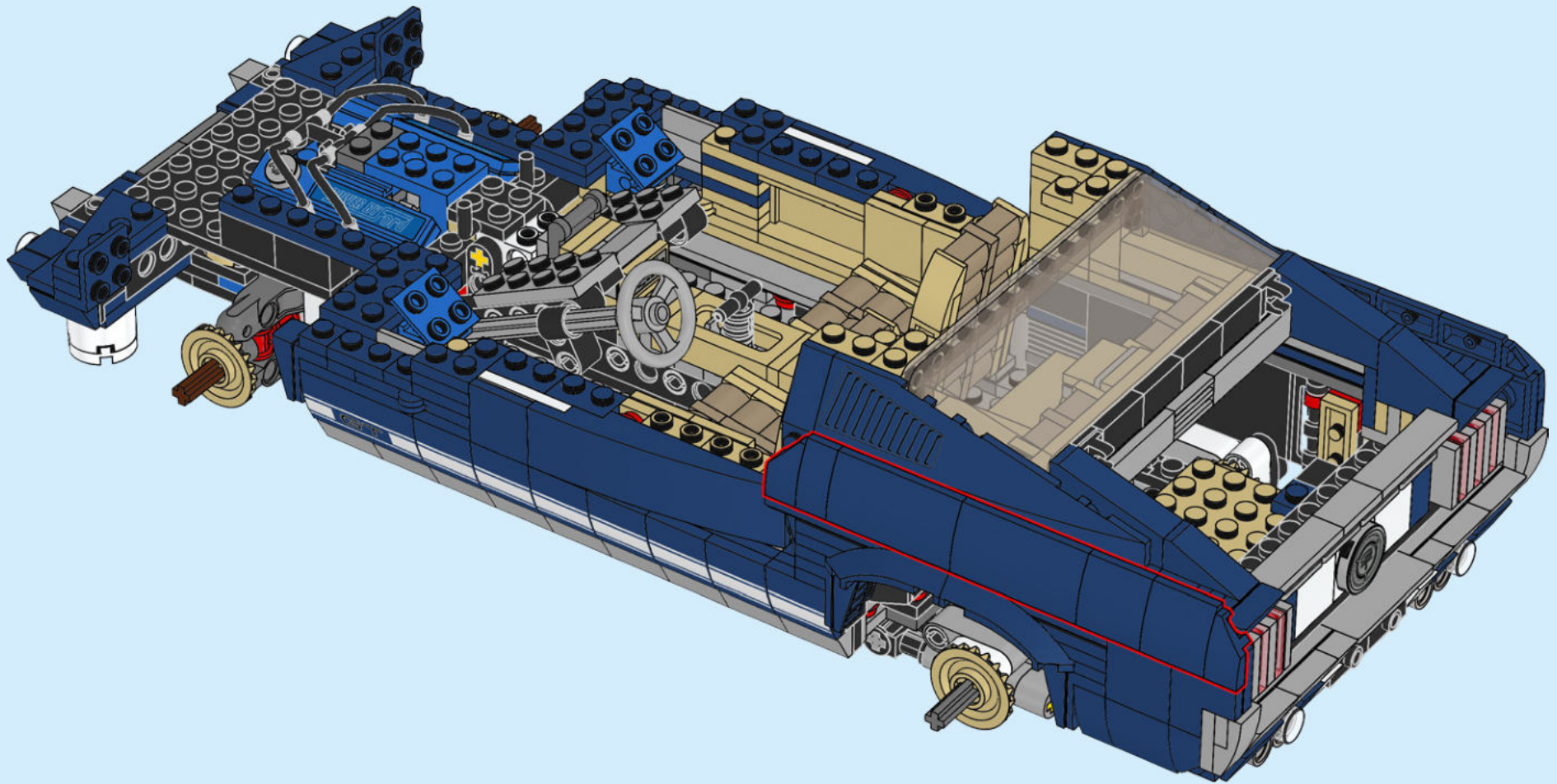

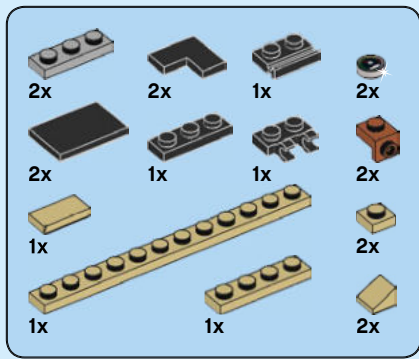

222

1

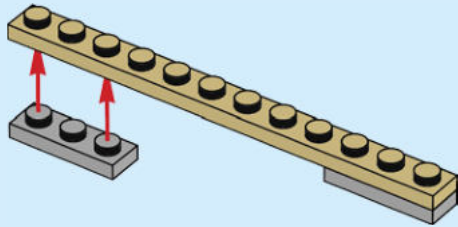

2

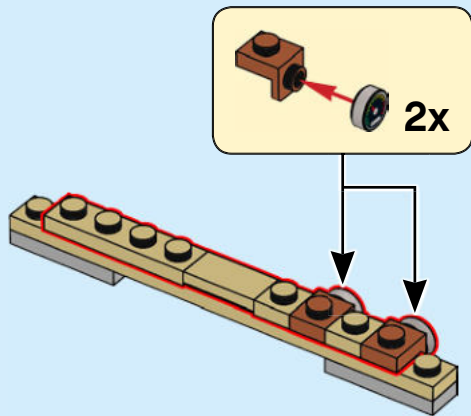

3

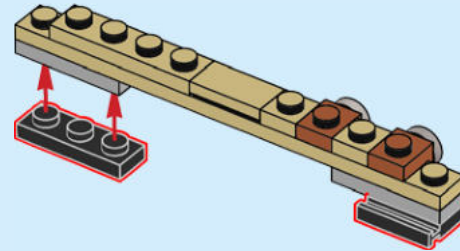

4

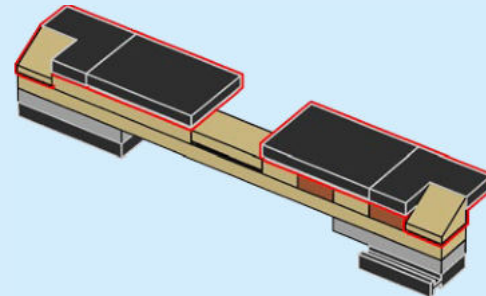

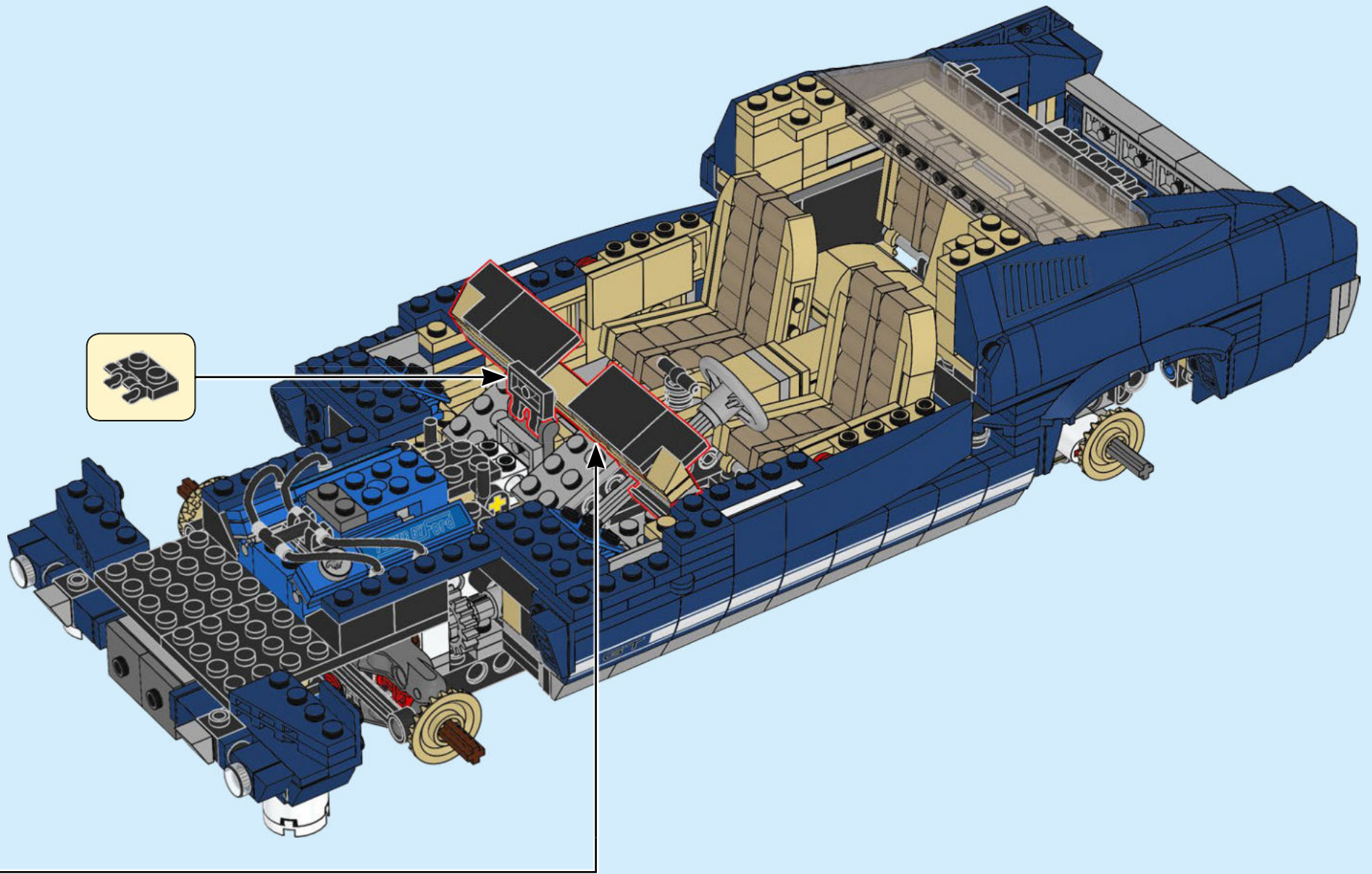

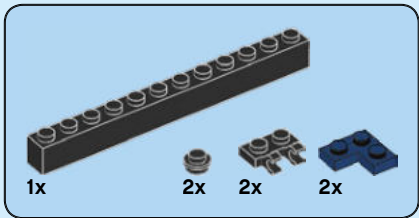

223

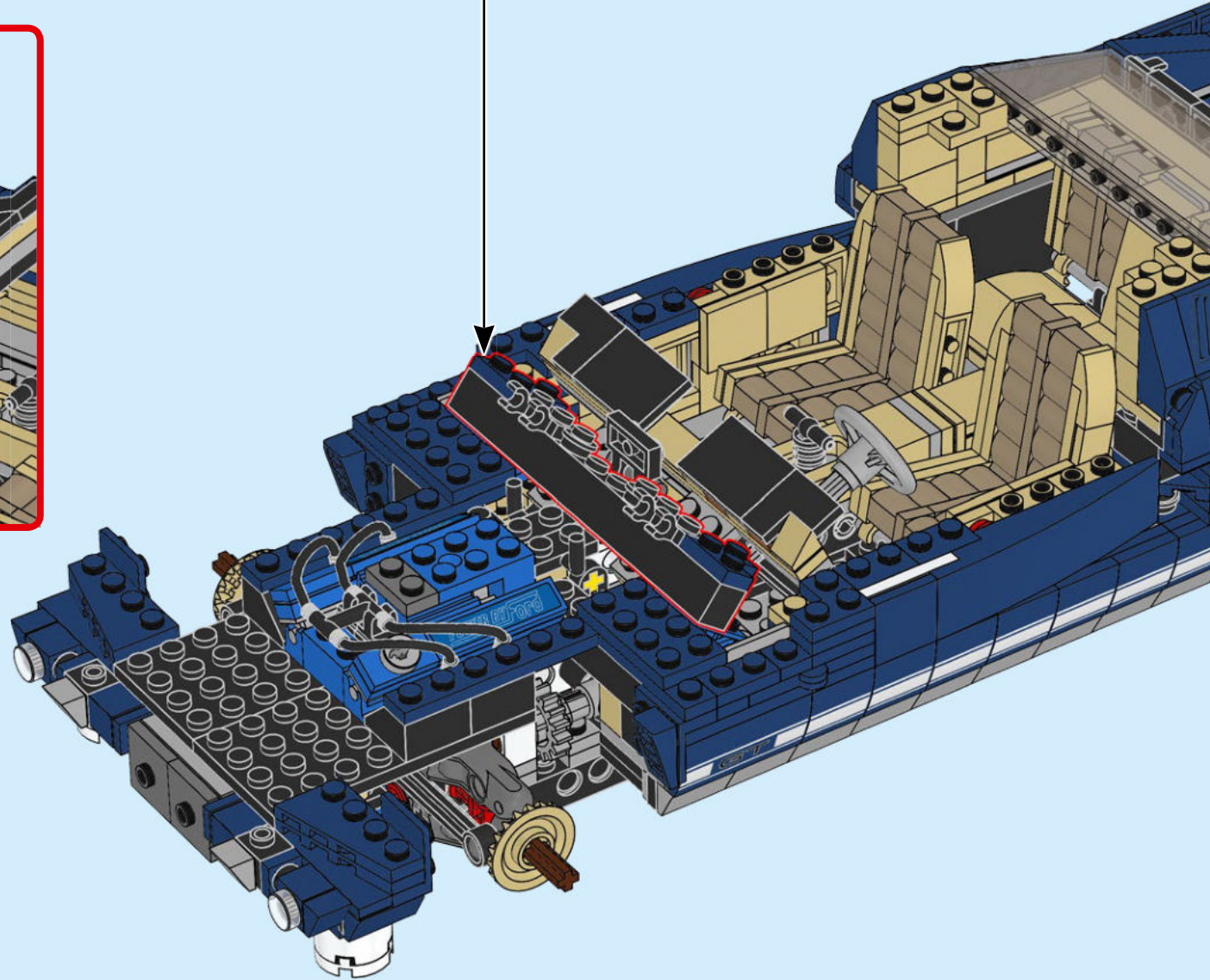
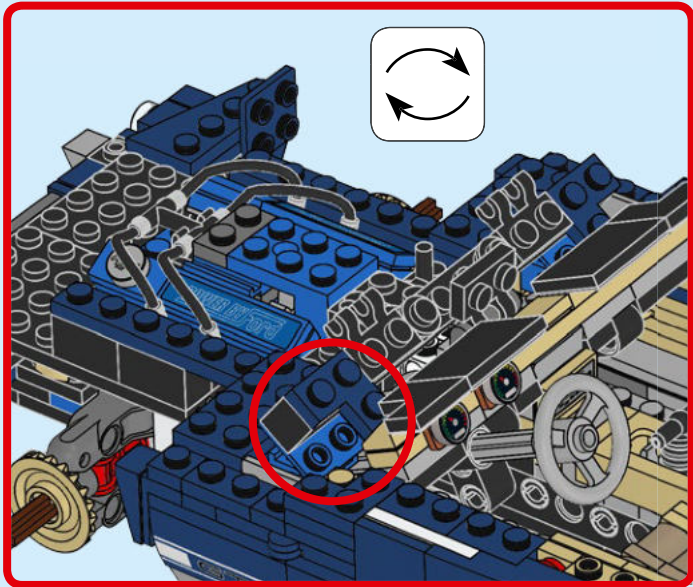
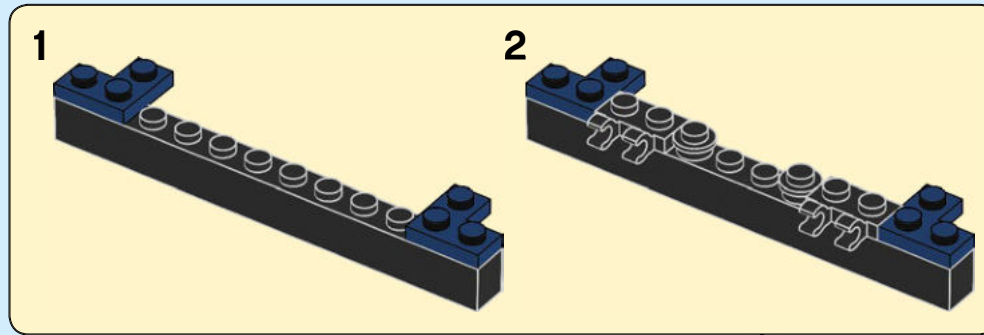

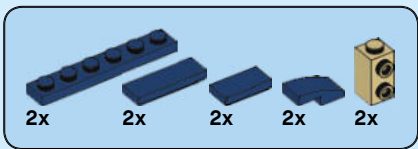

224

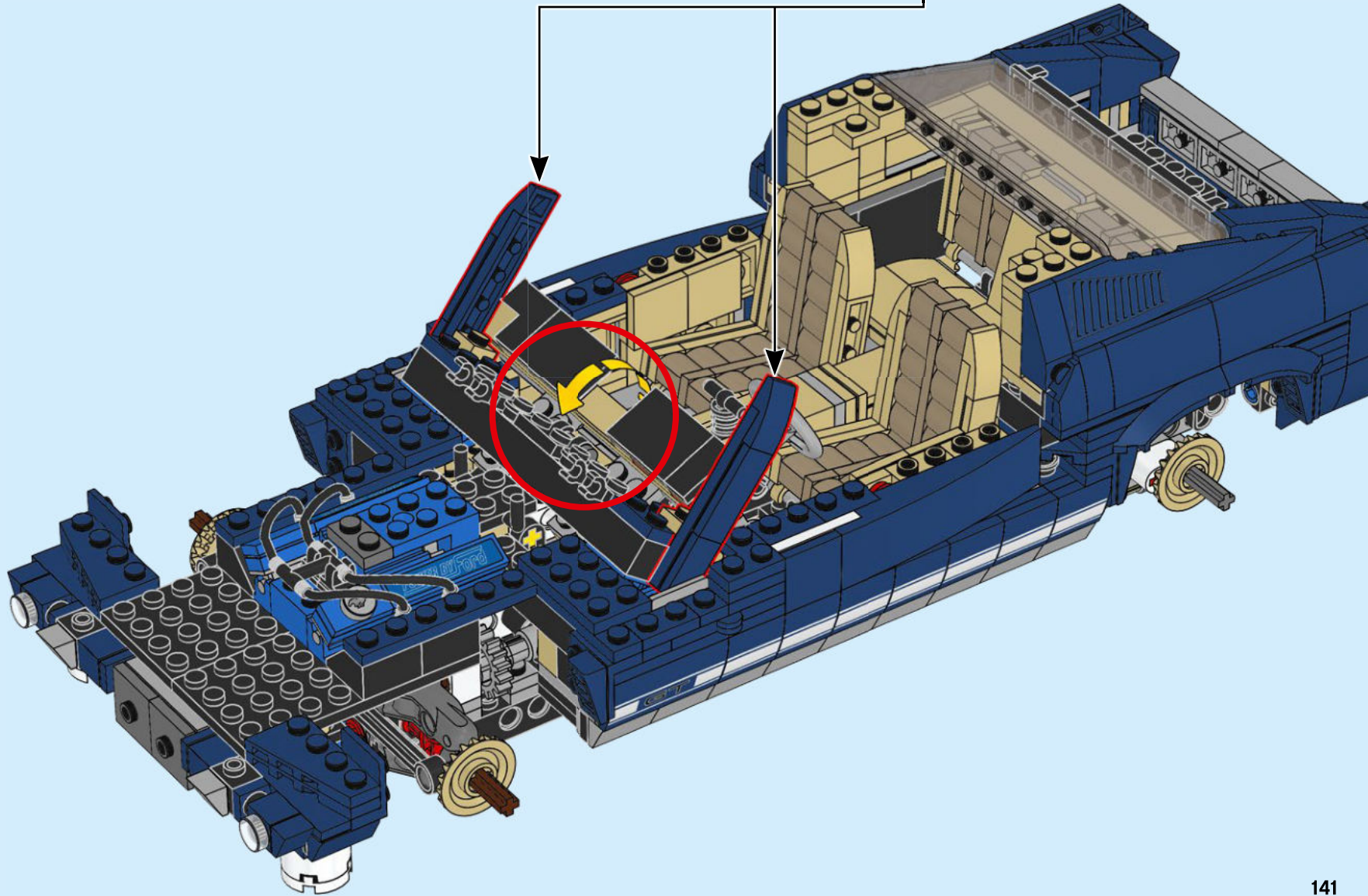
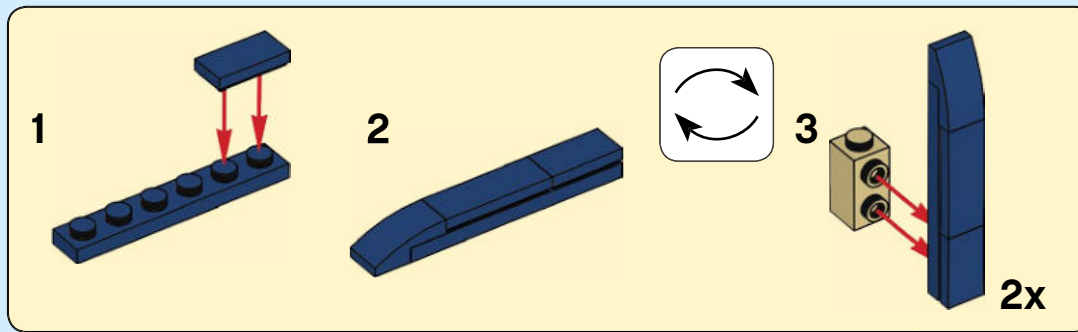

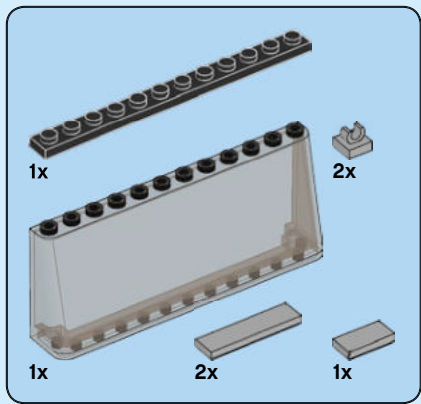

225

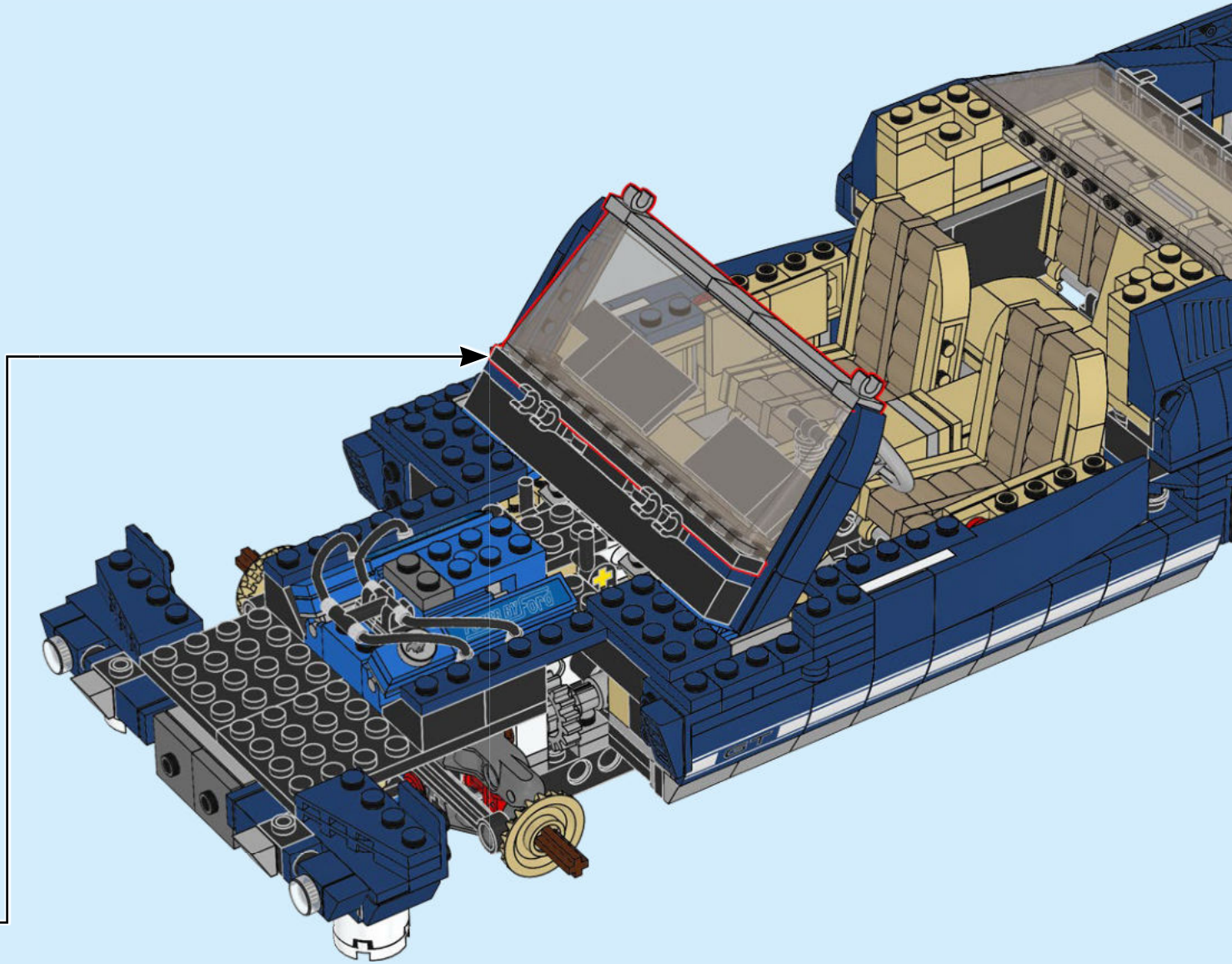
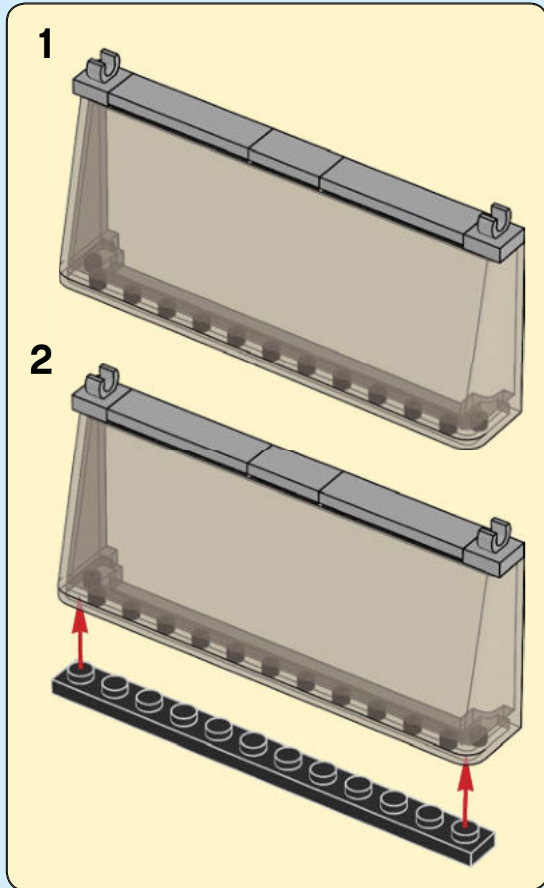

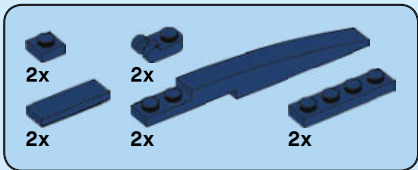

226

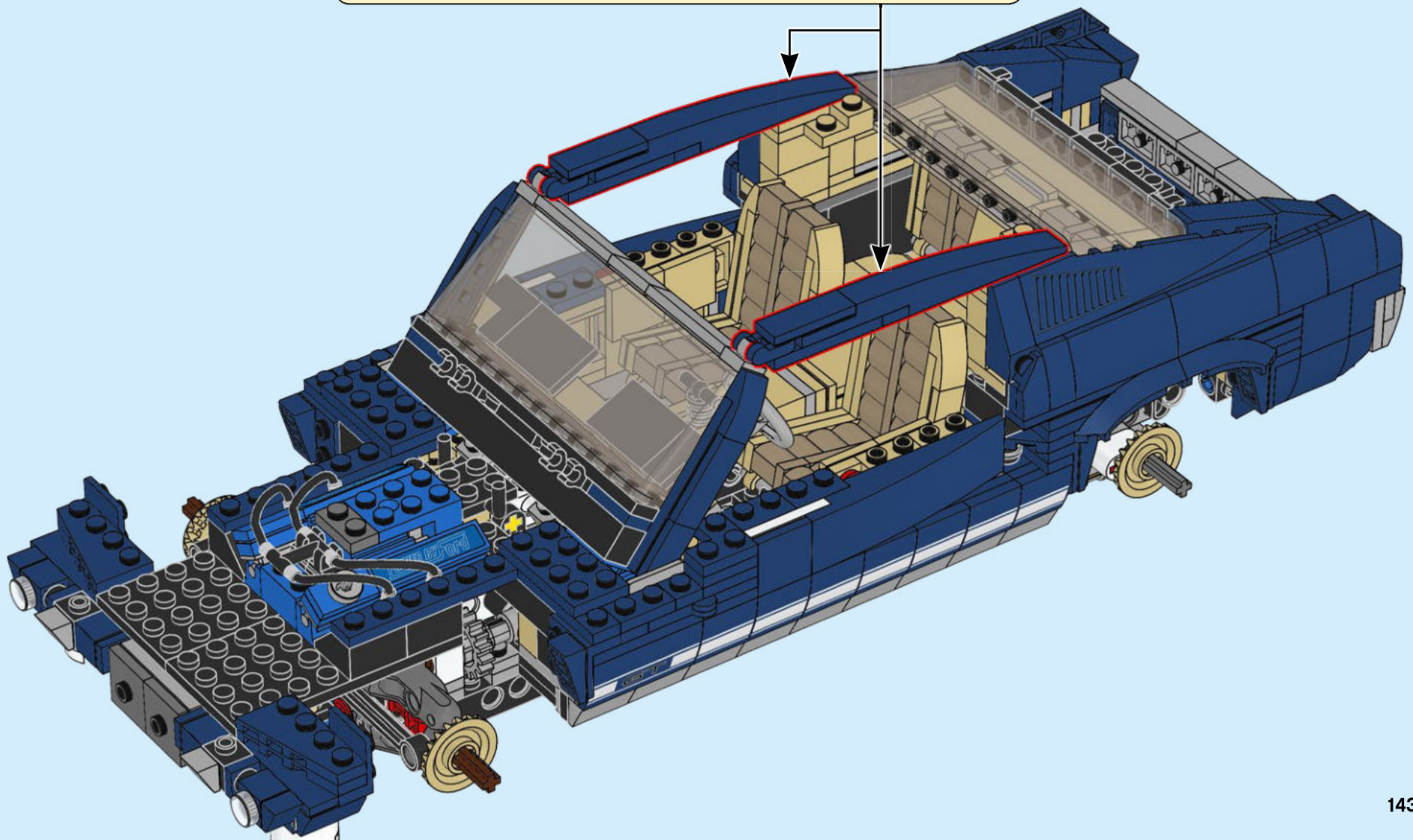
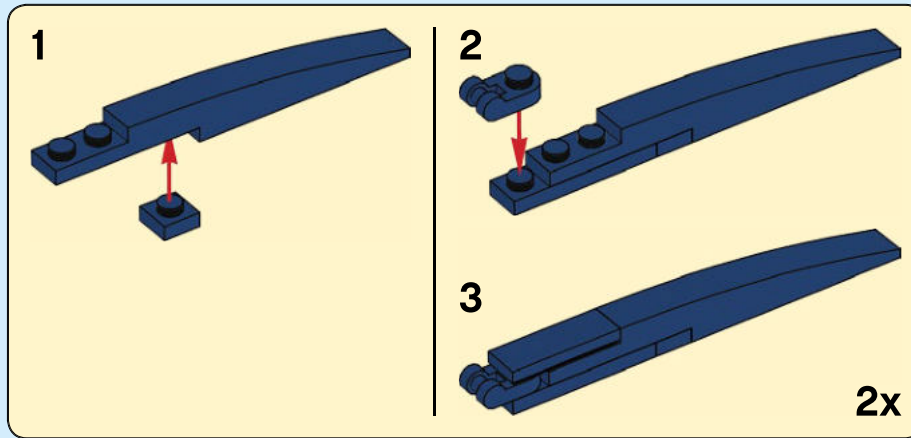

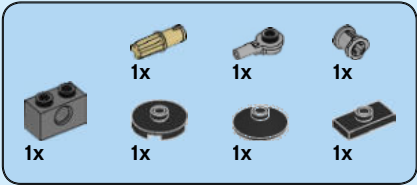
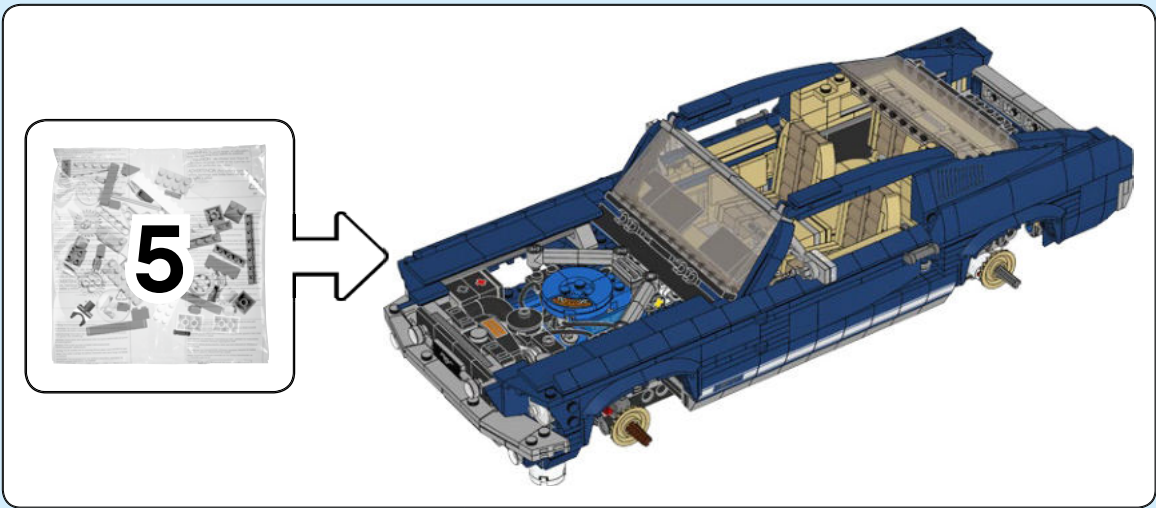

227

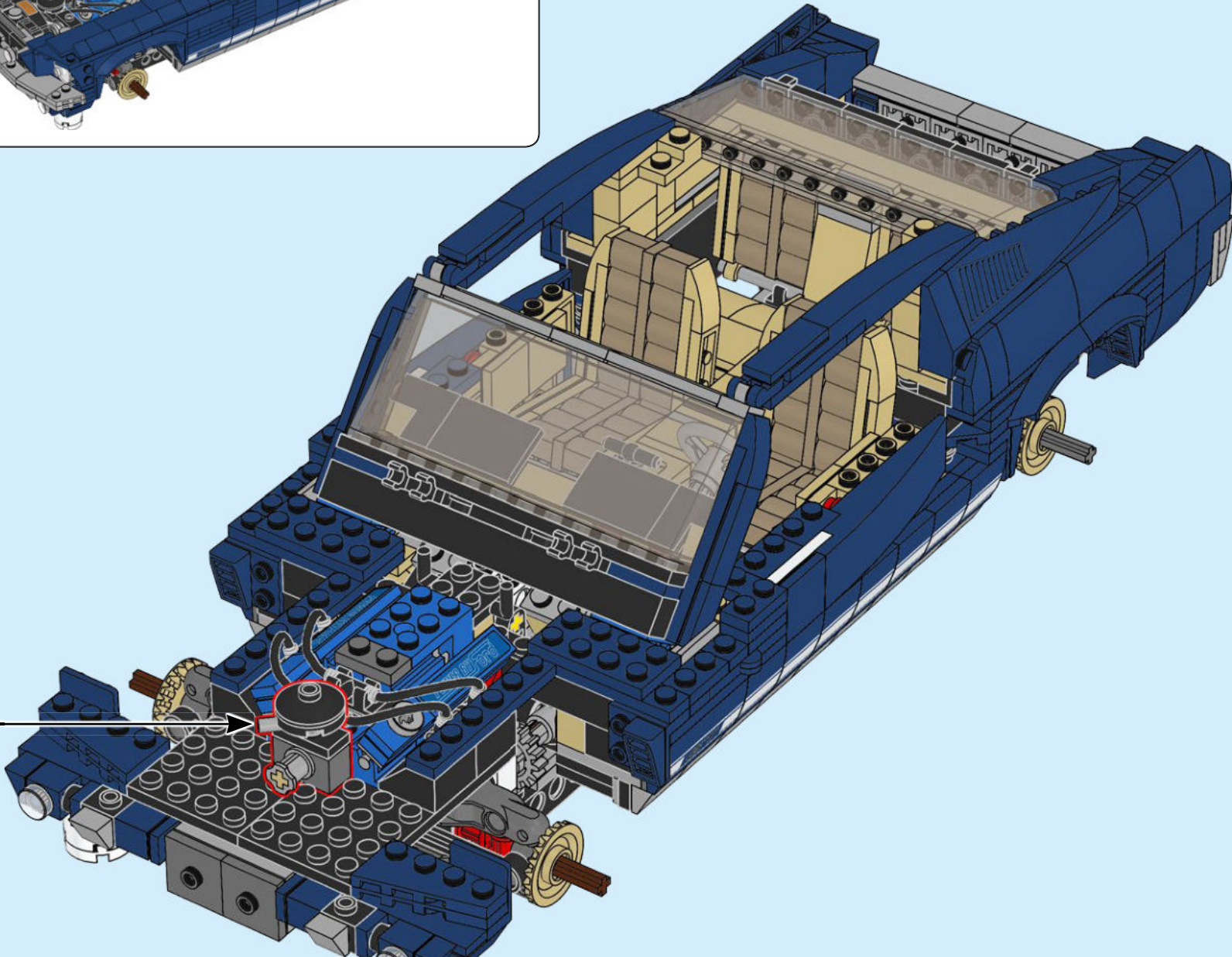
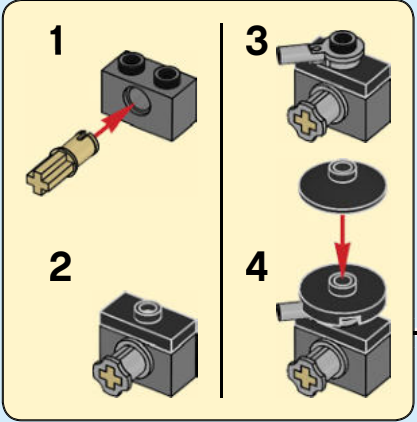

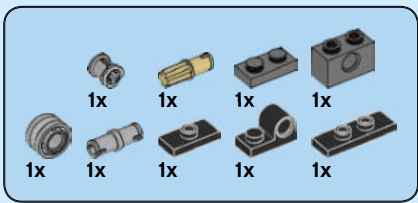

228

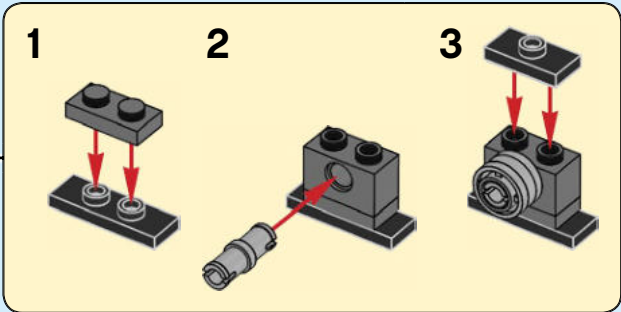
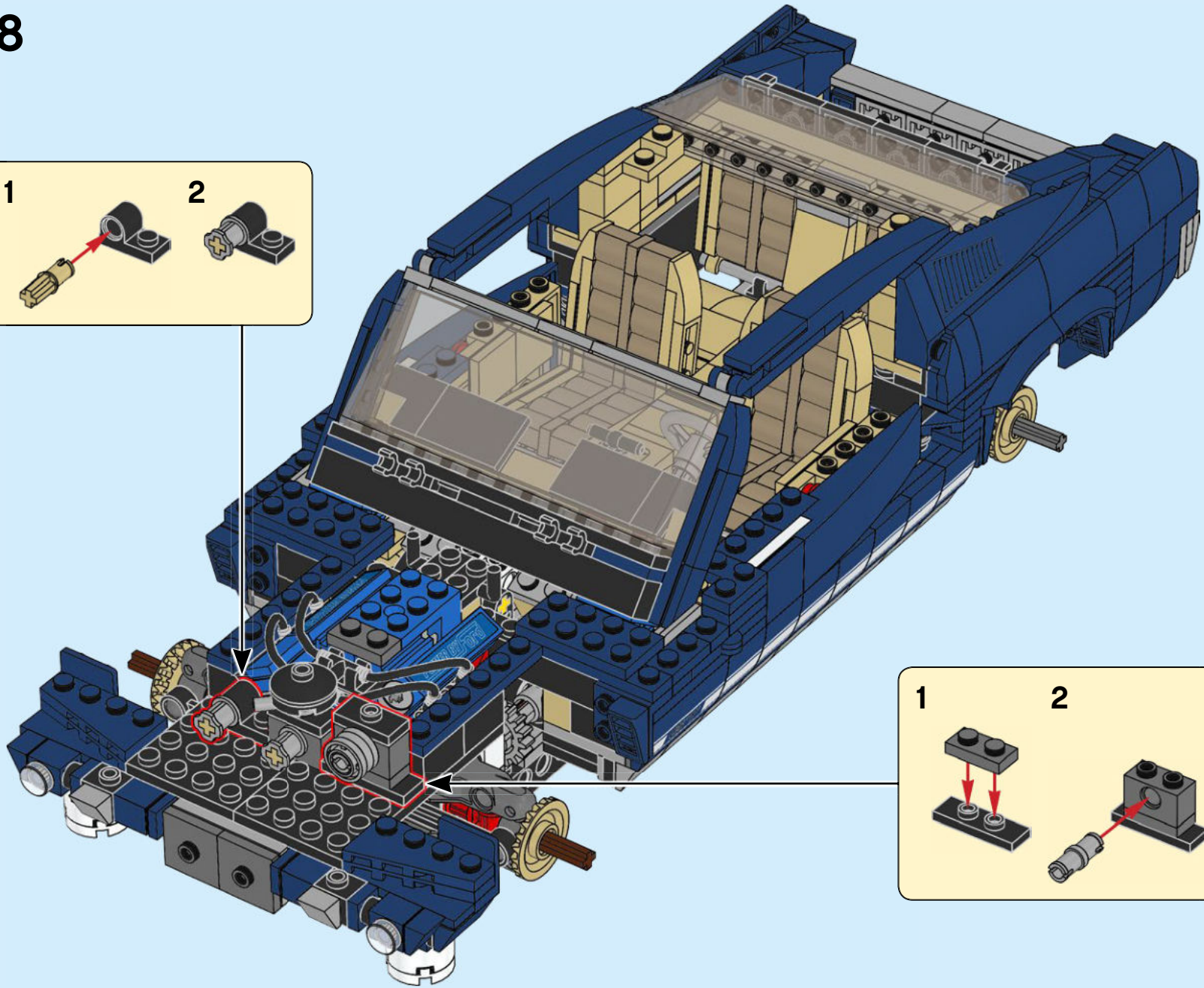
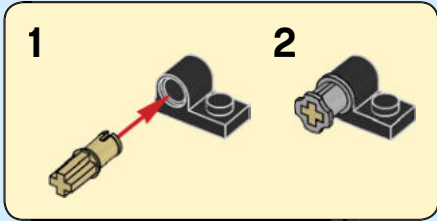



2x

229

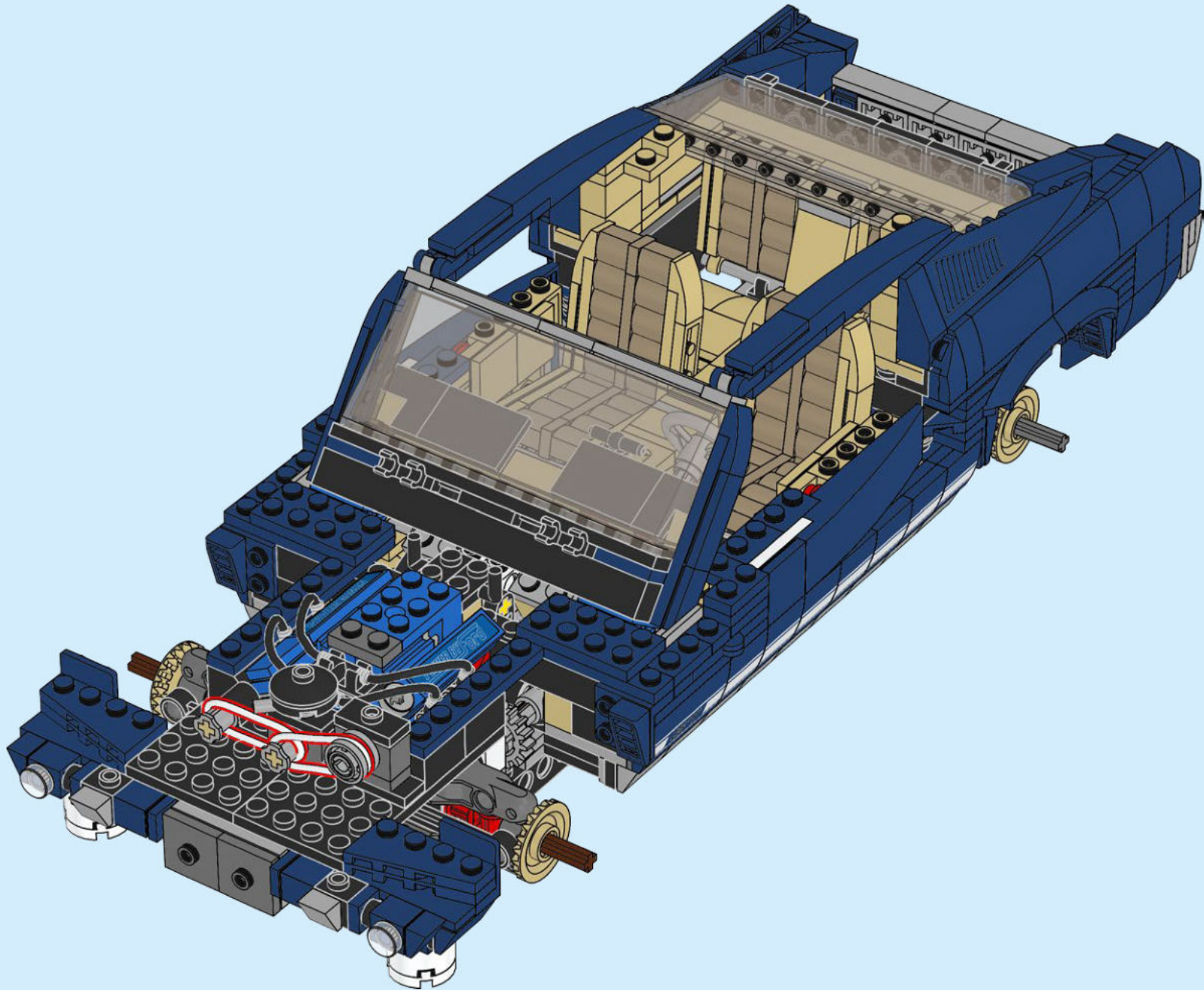

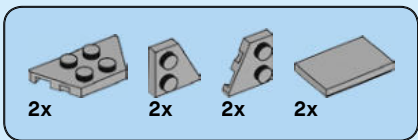

230

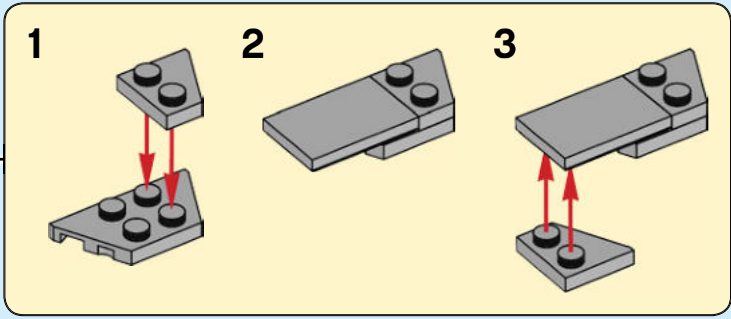
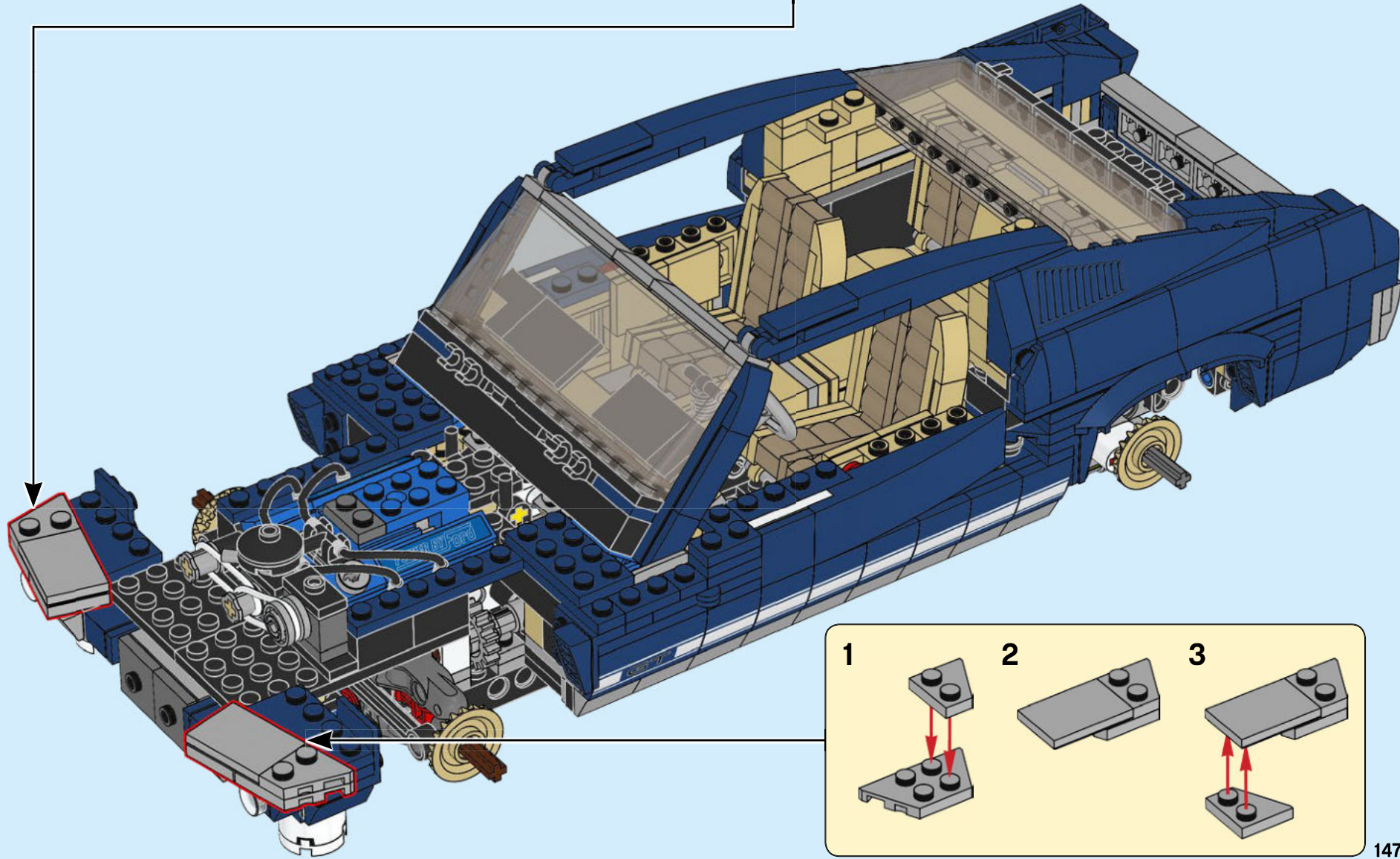
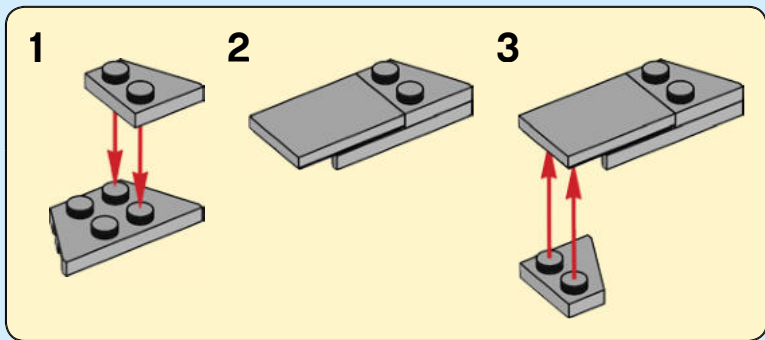

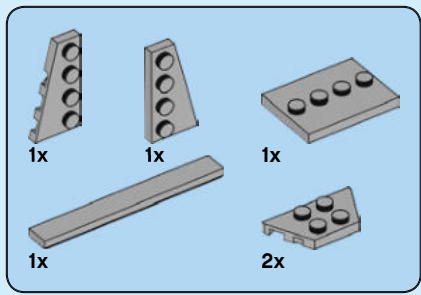

231

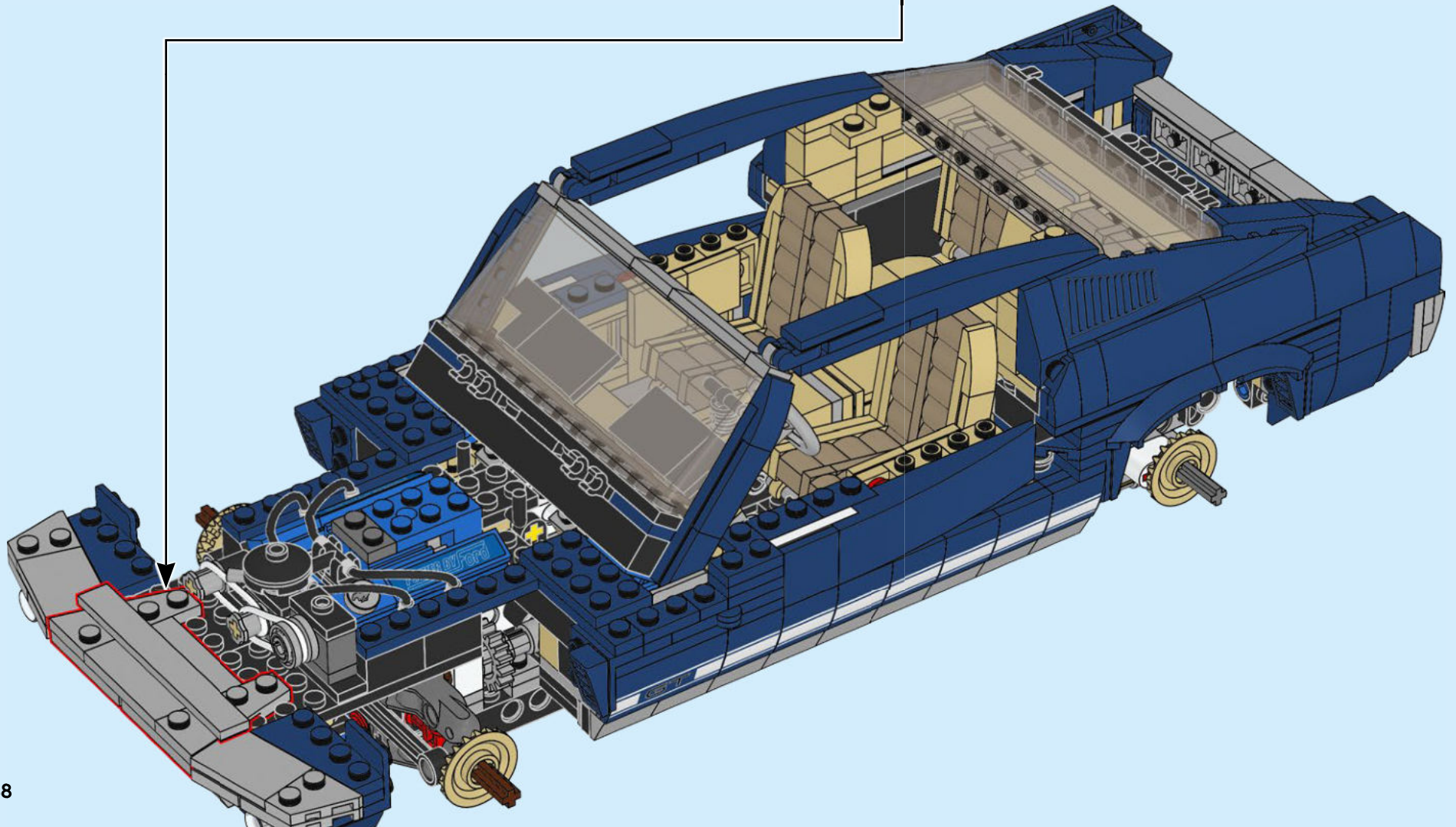
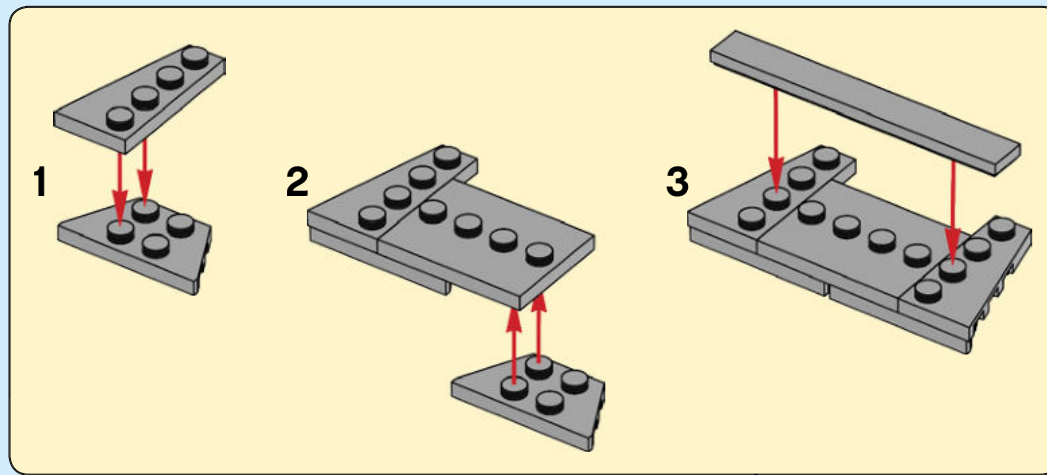

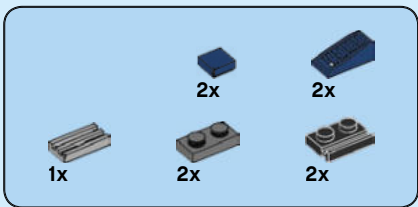

232

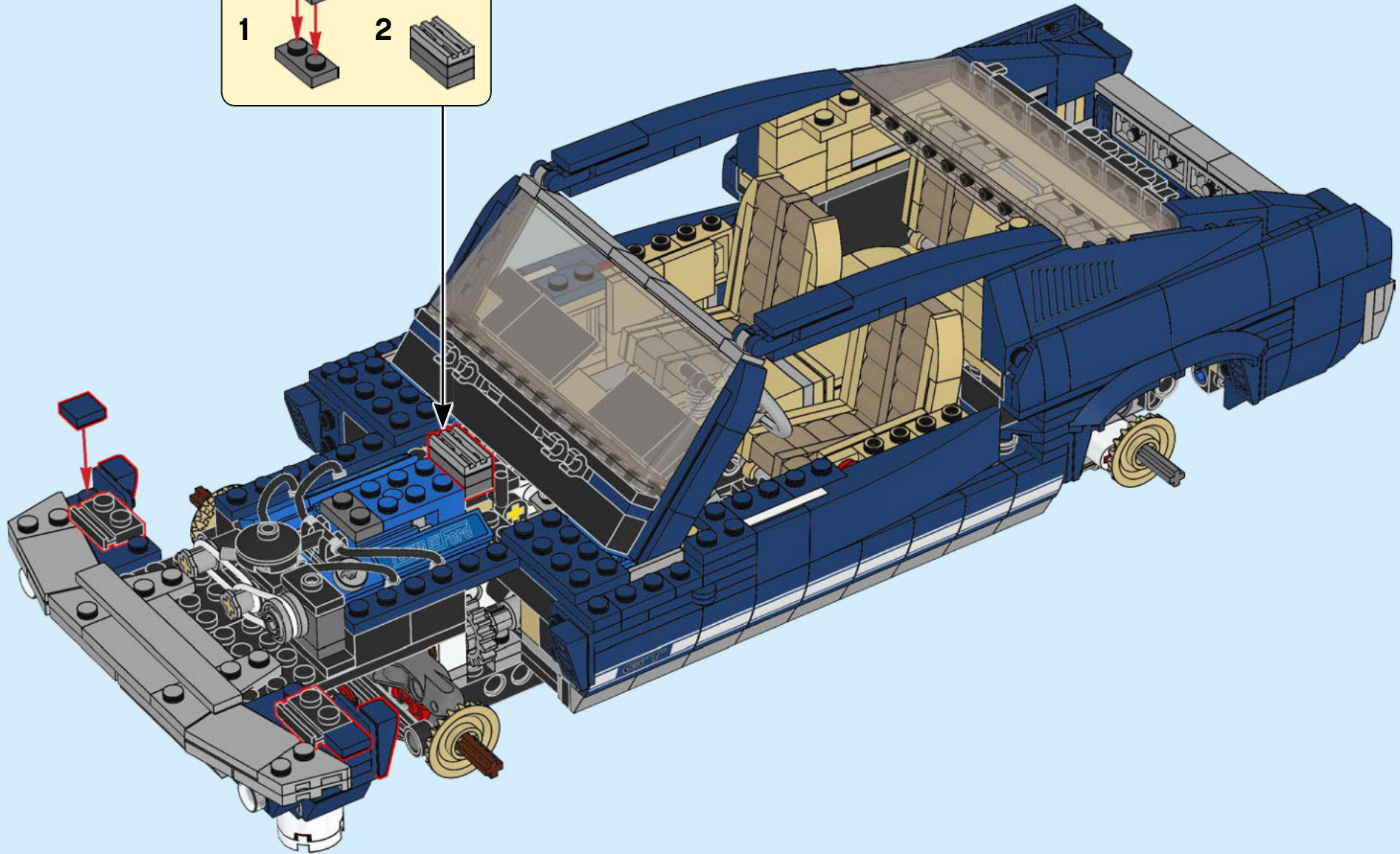
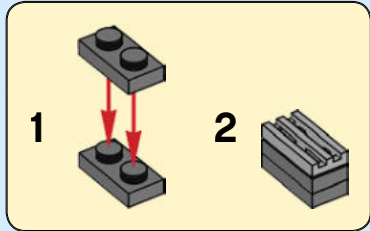

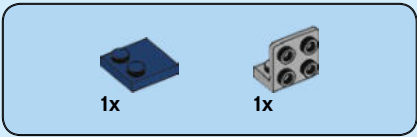

233

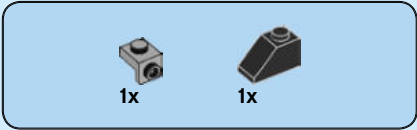
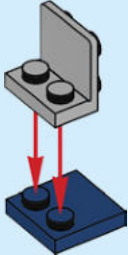

234

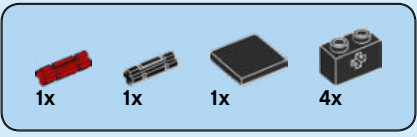
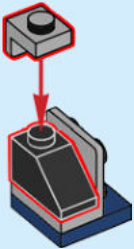

235

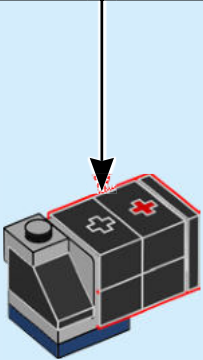
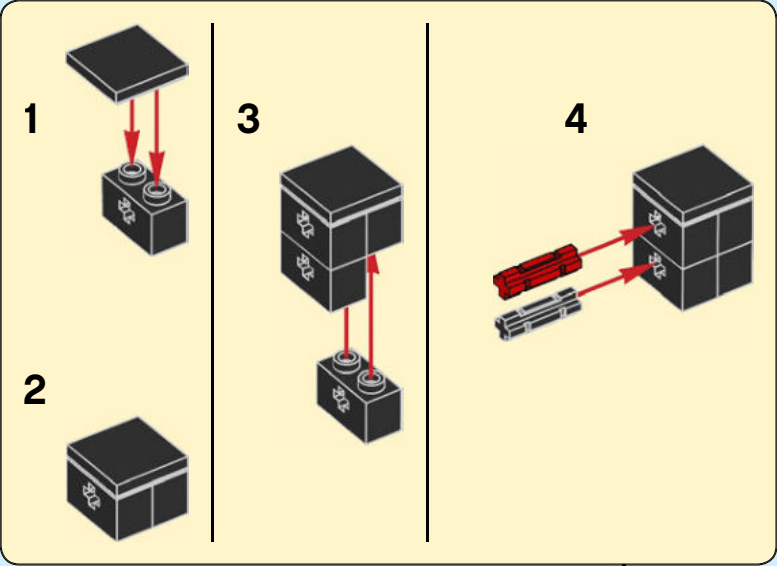

236

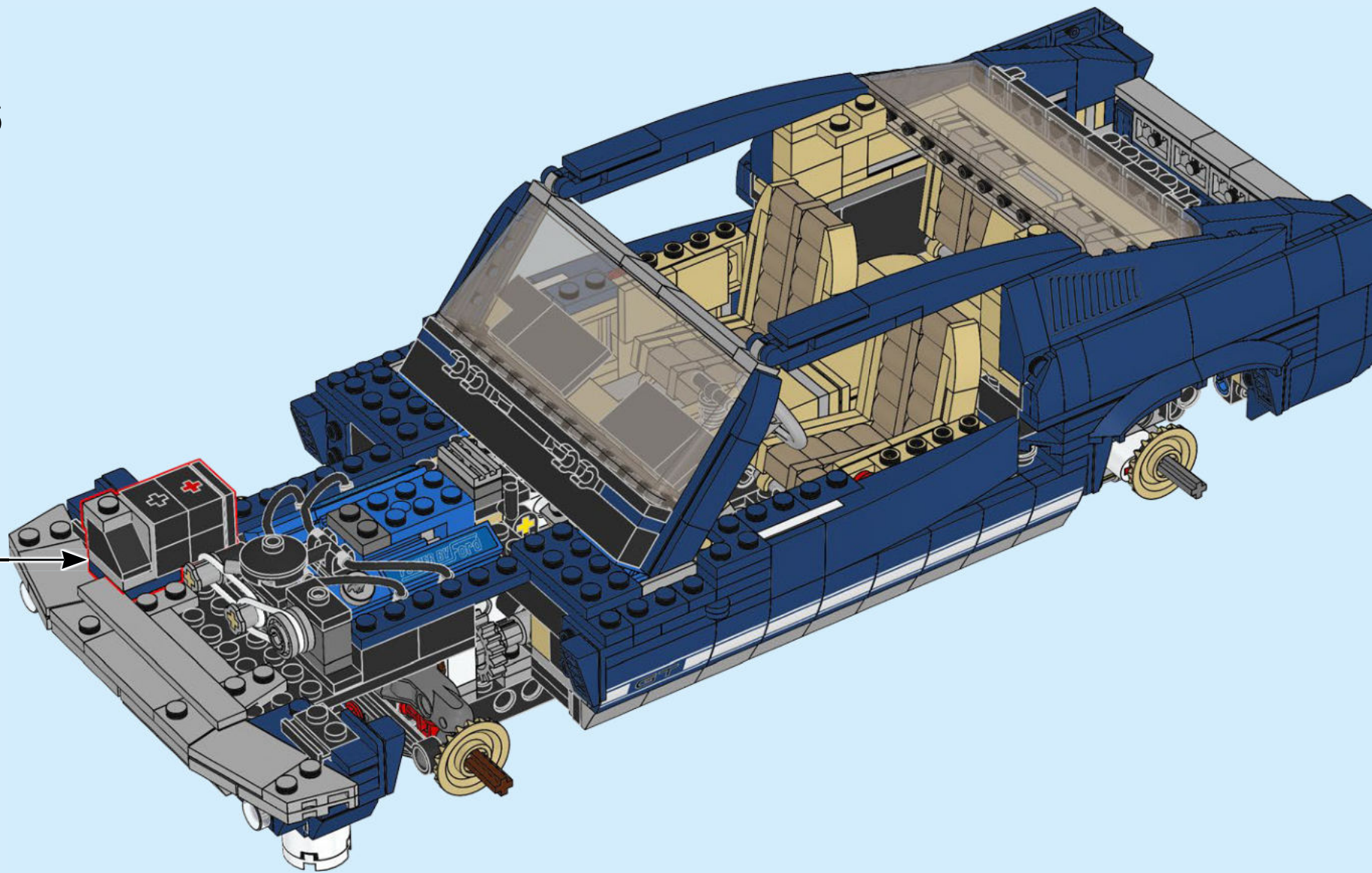

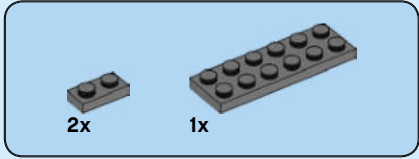

237

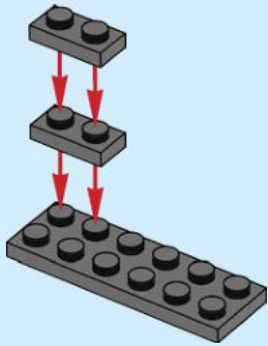

238

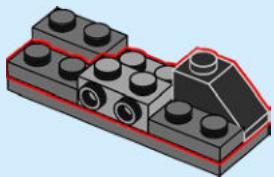

239

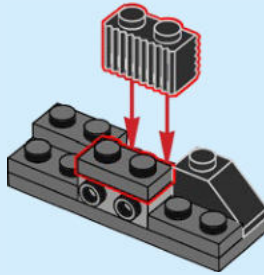

240

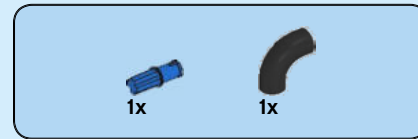
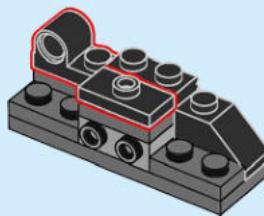

241

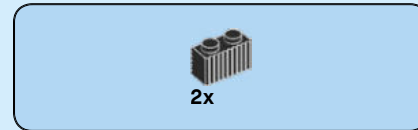
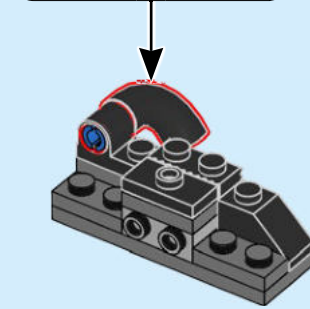
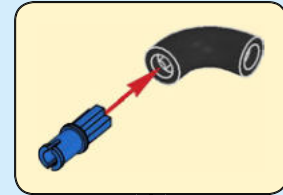

242

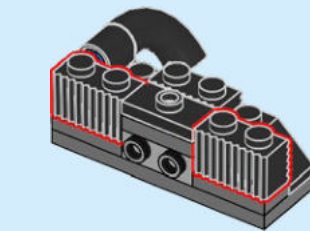

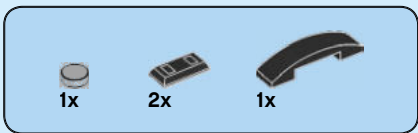

243

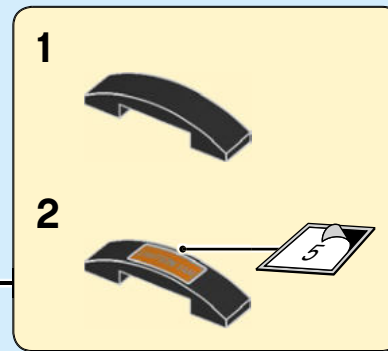
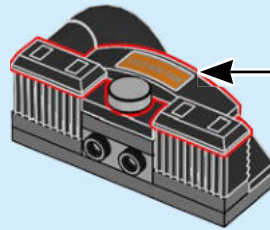

244

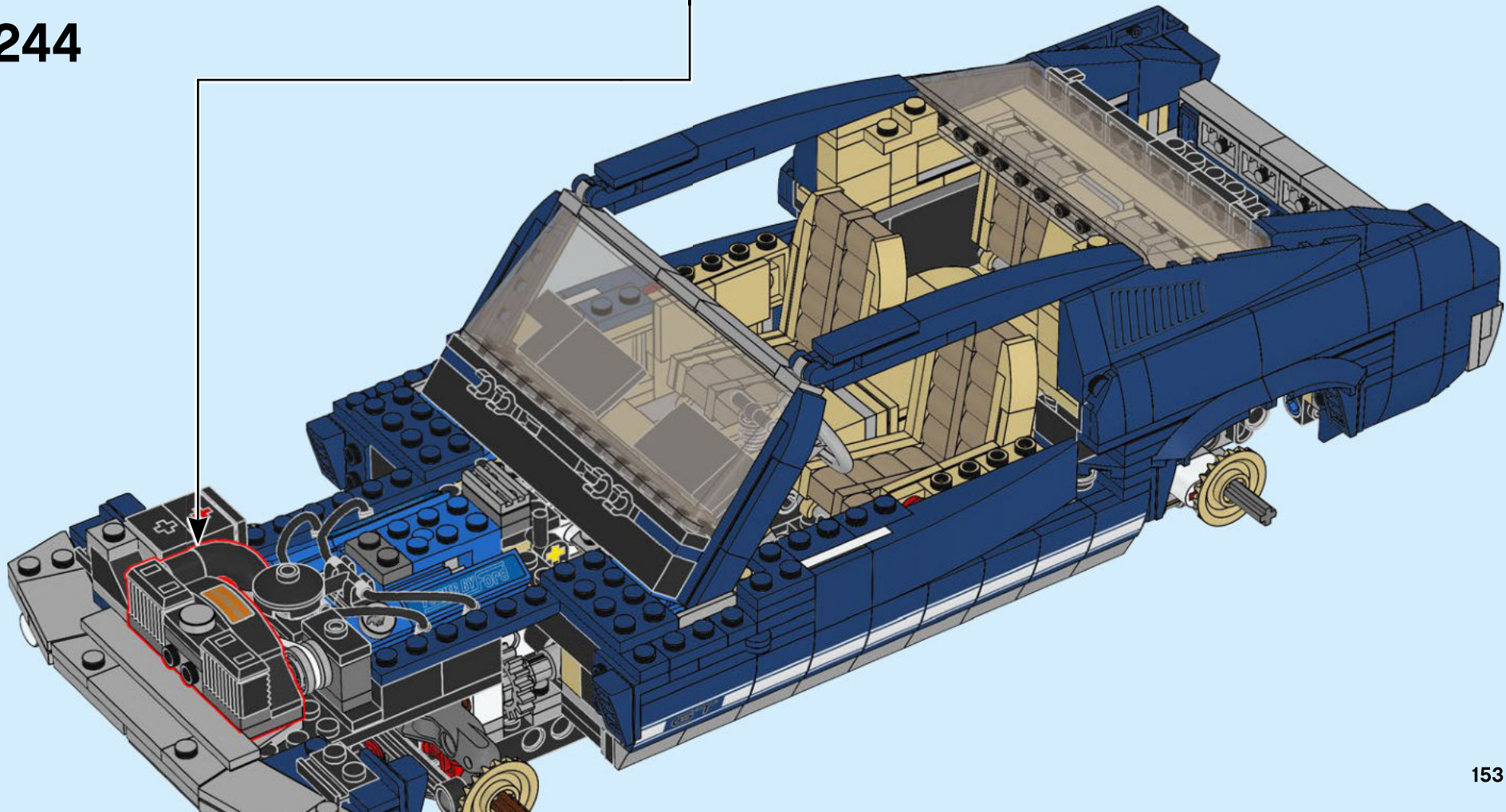

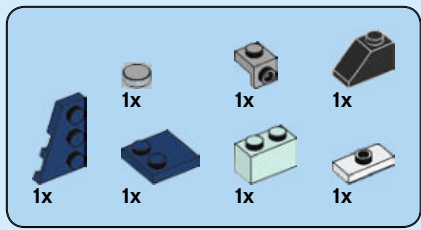

245

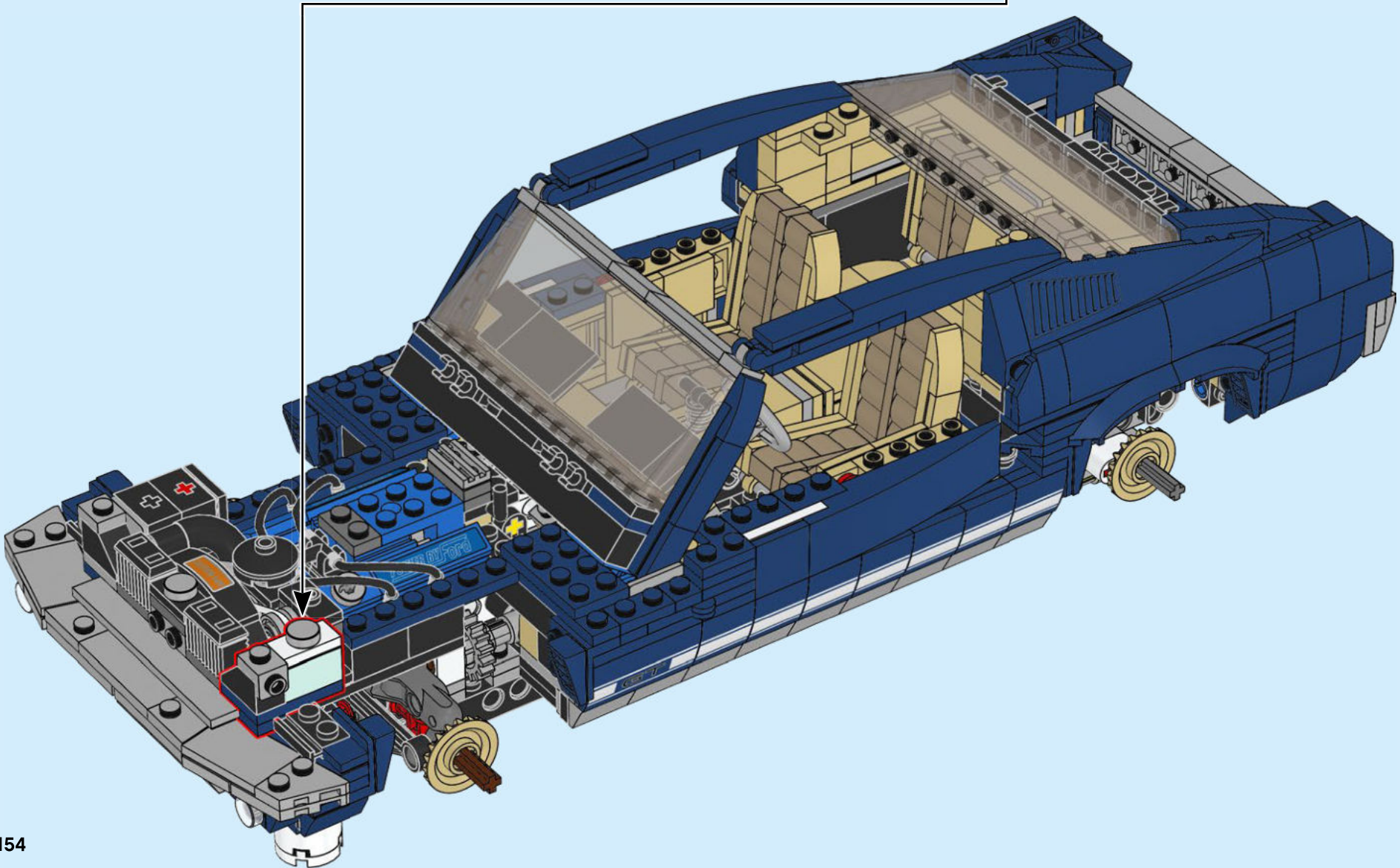
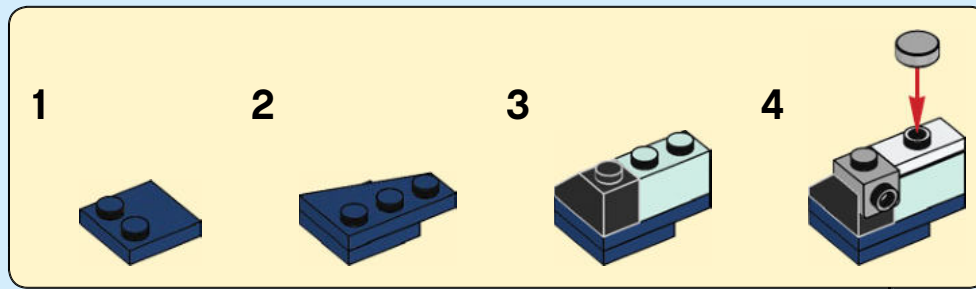

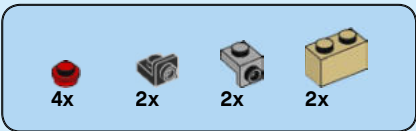

246

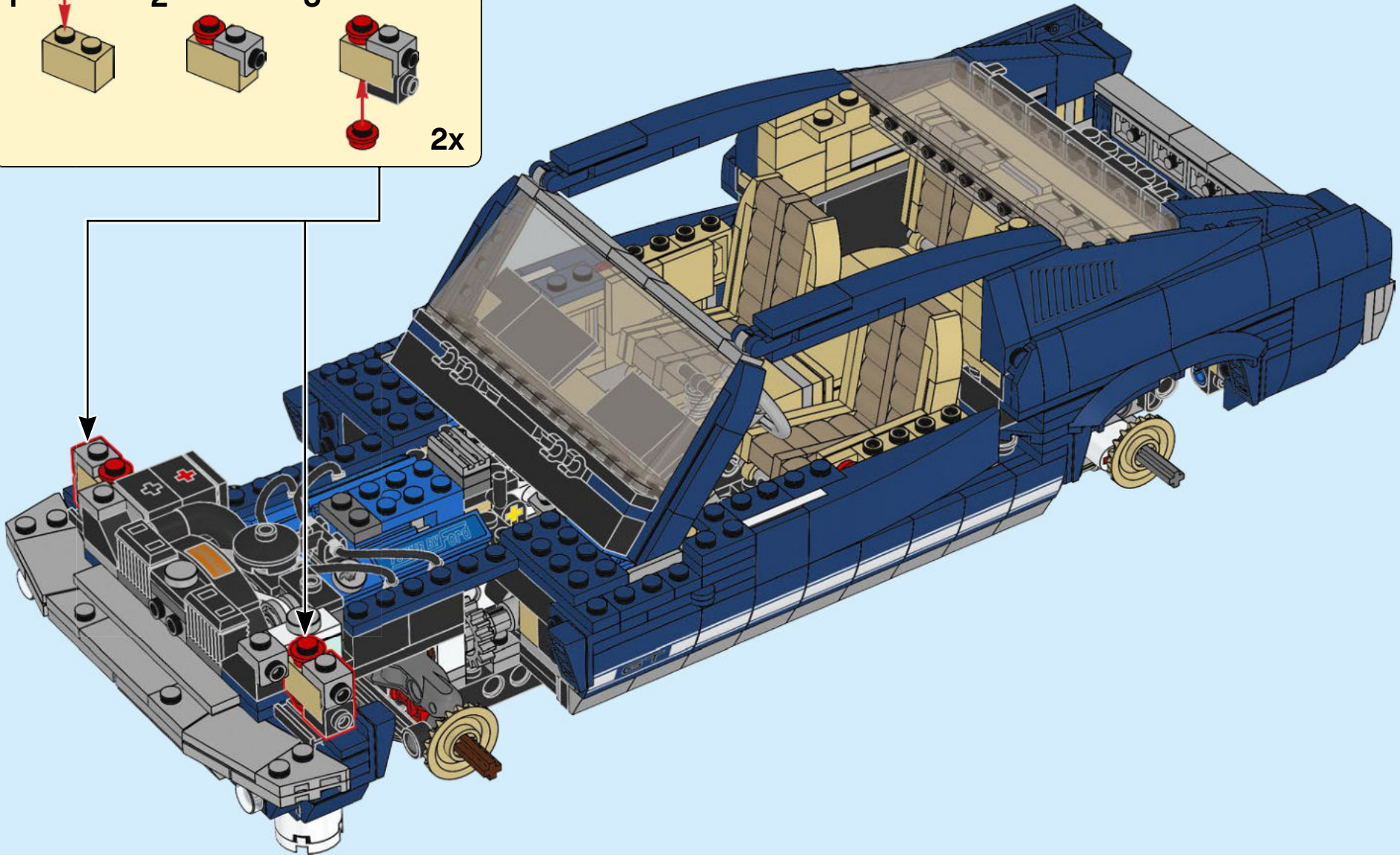
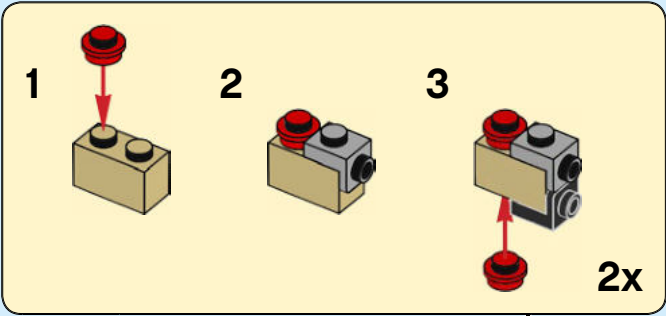

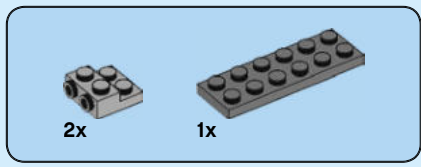

247

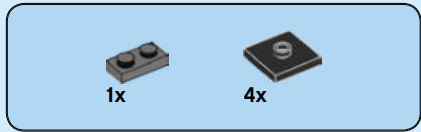
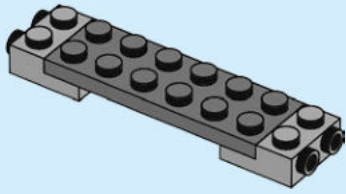

248

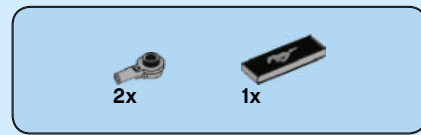
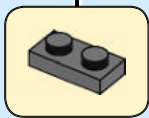
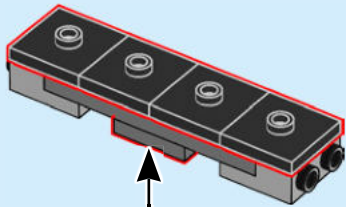

249

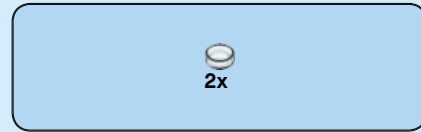
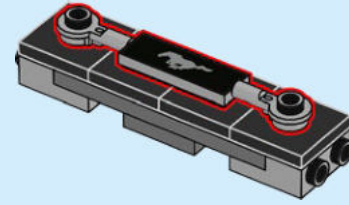

250

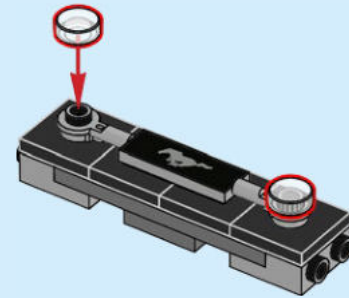

251

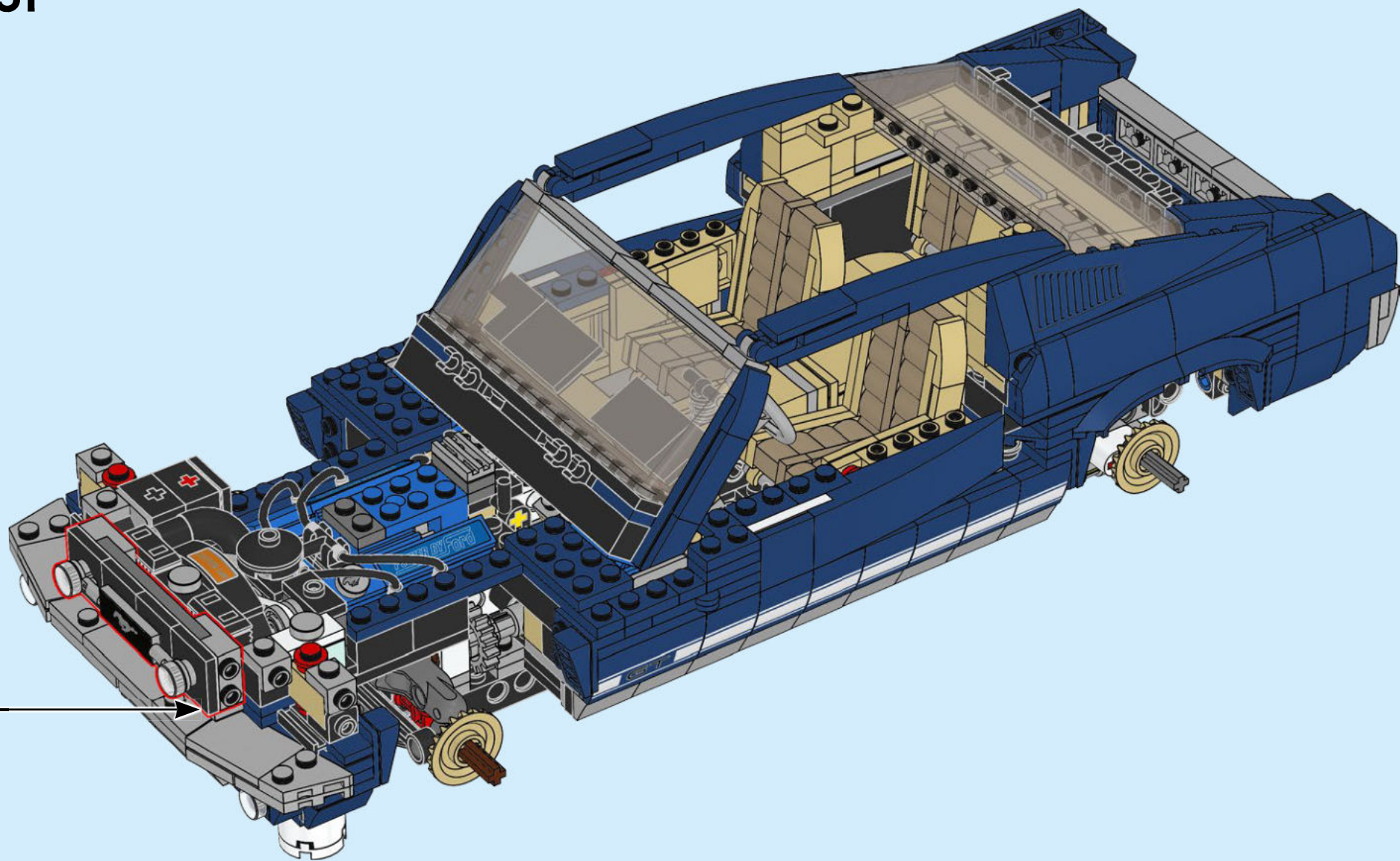

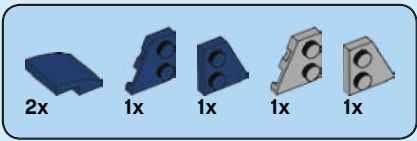

252

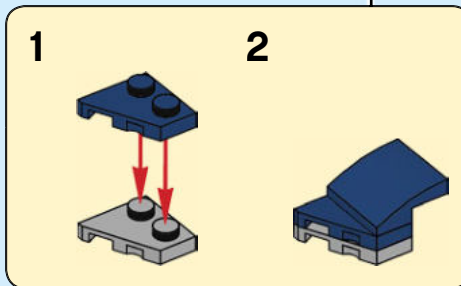
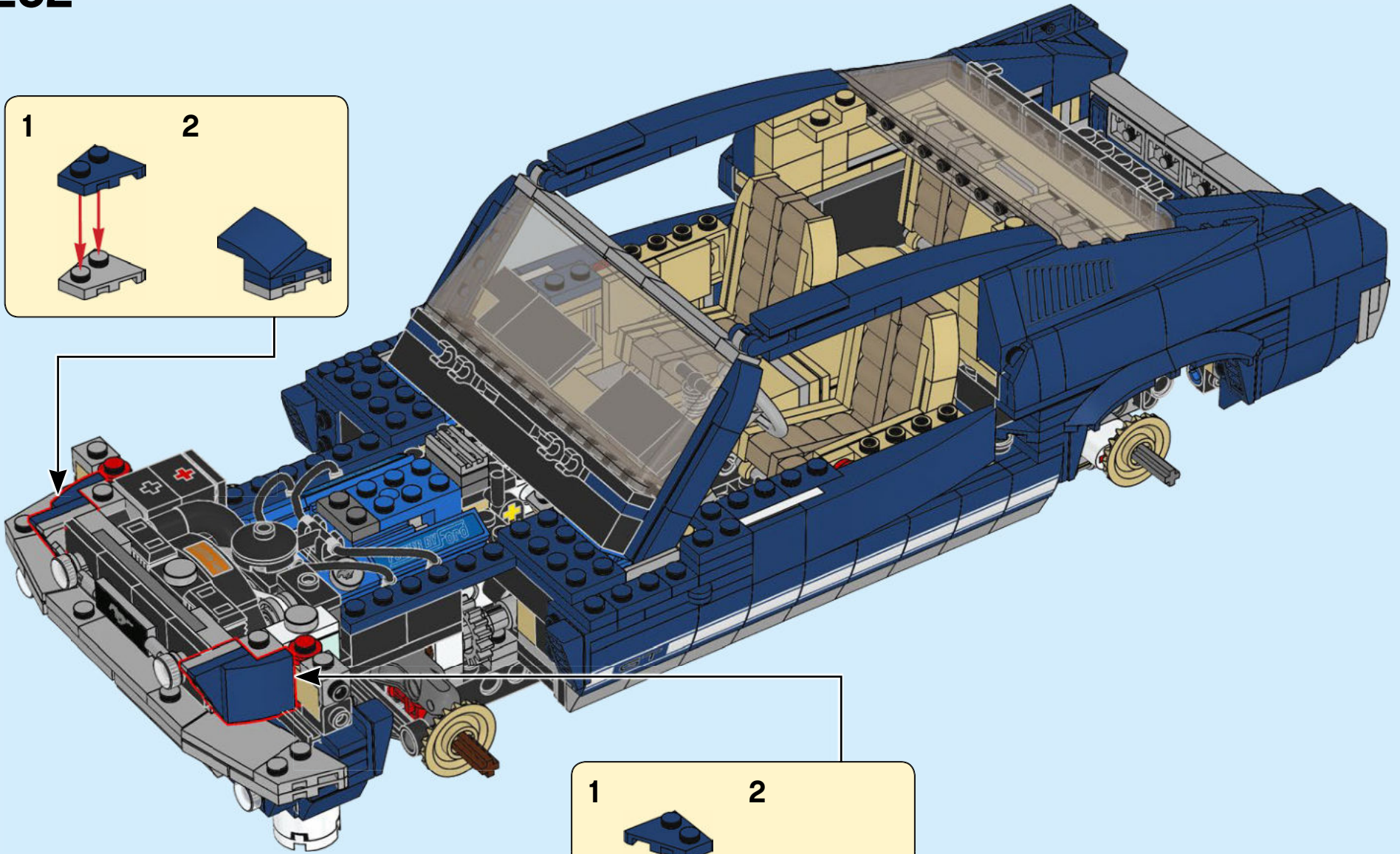
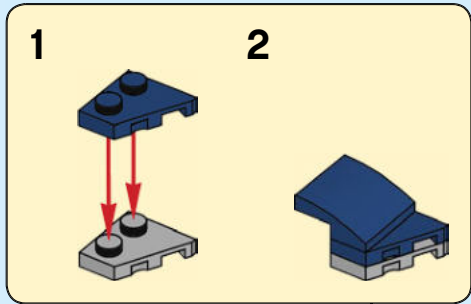

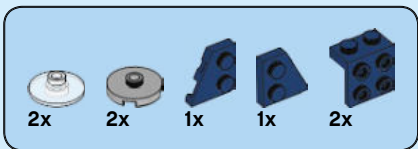

253

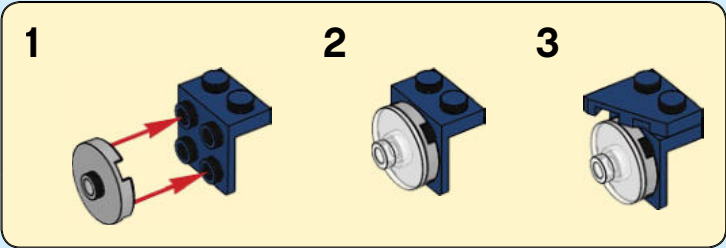
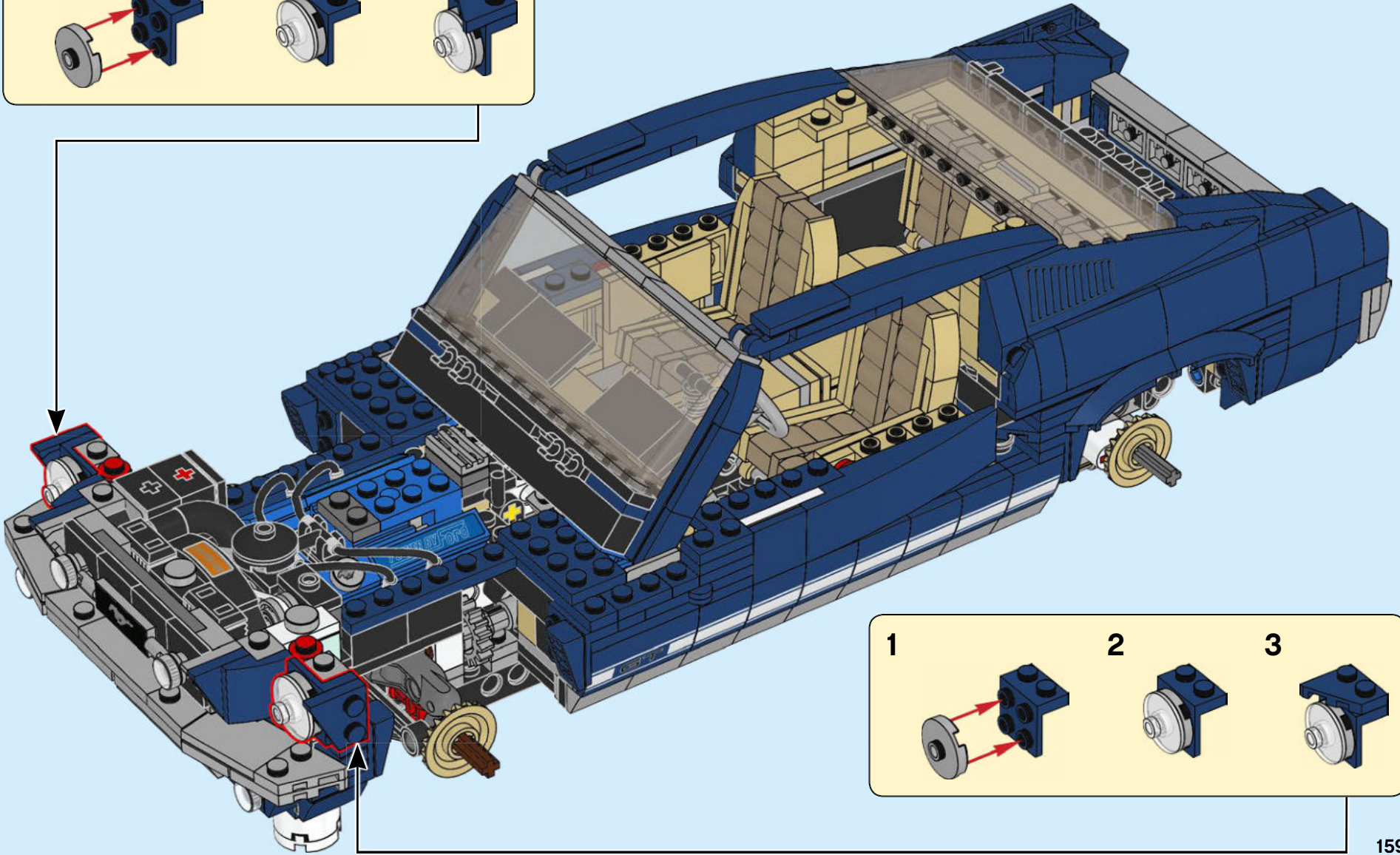
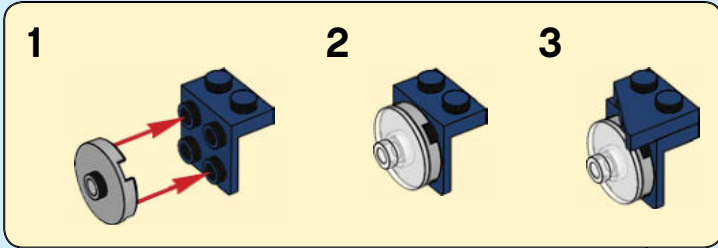

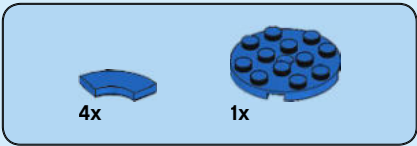

254

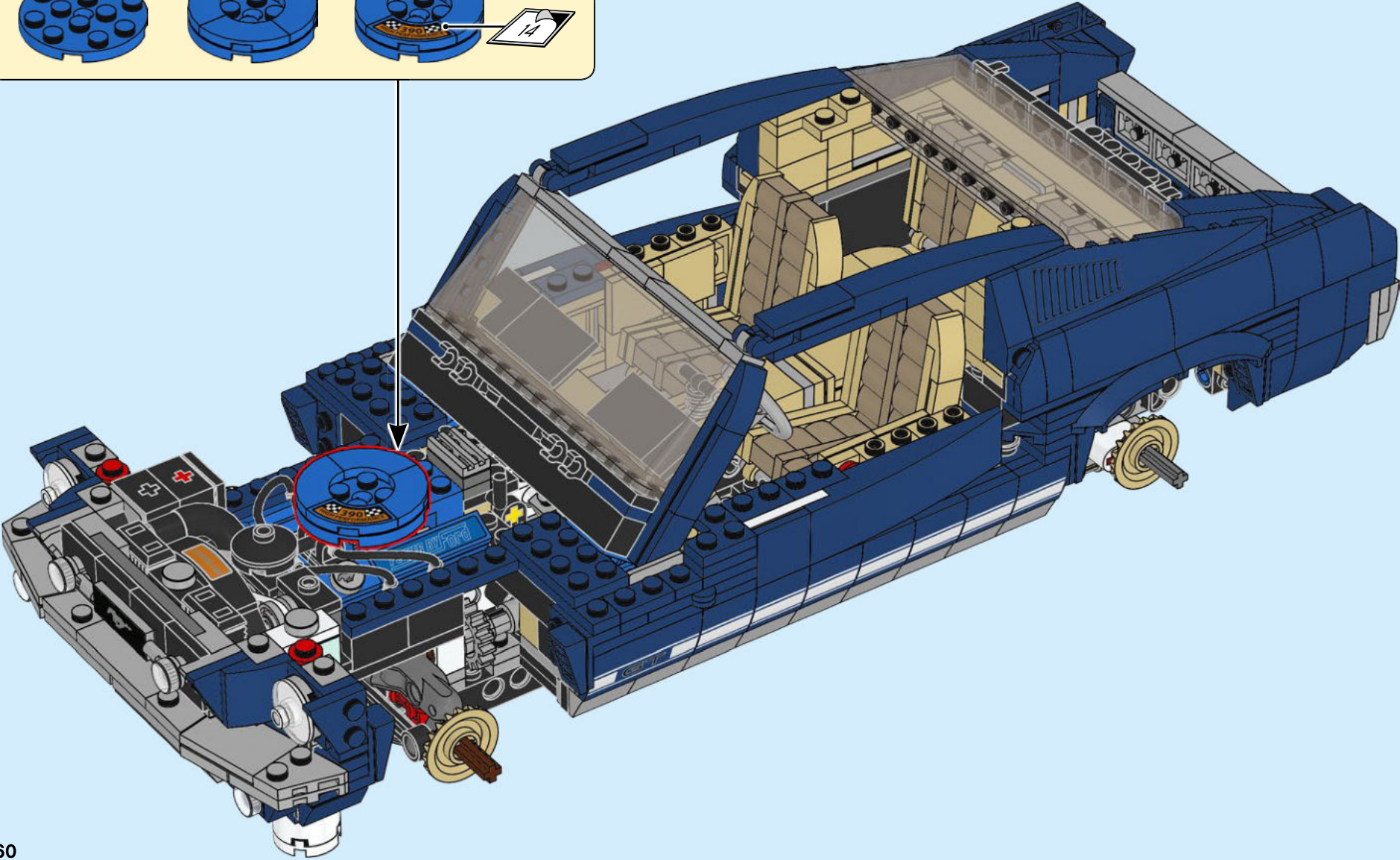
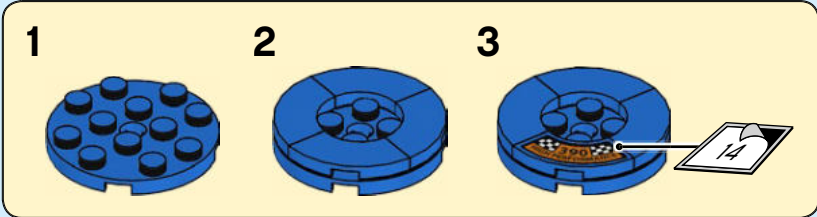

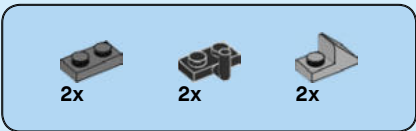

255

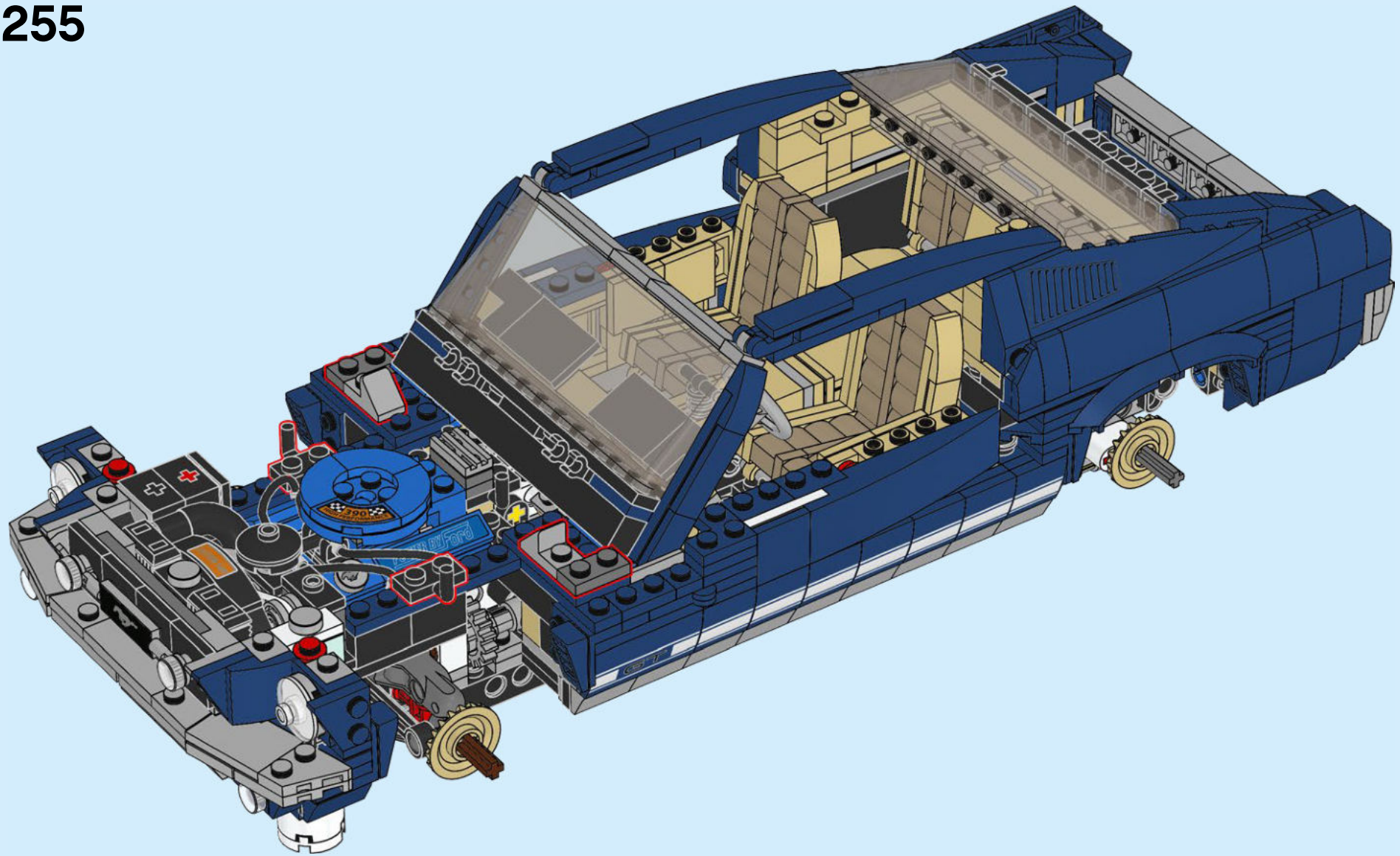

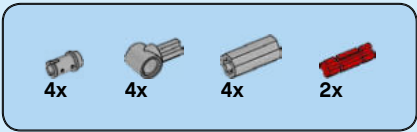

256

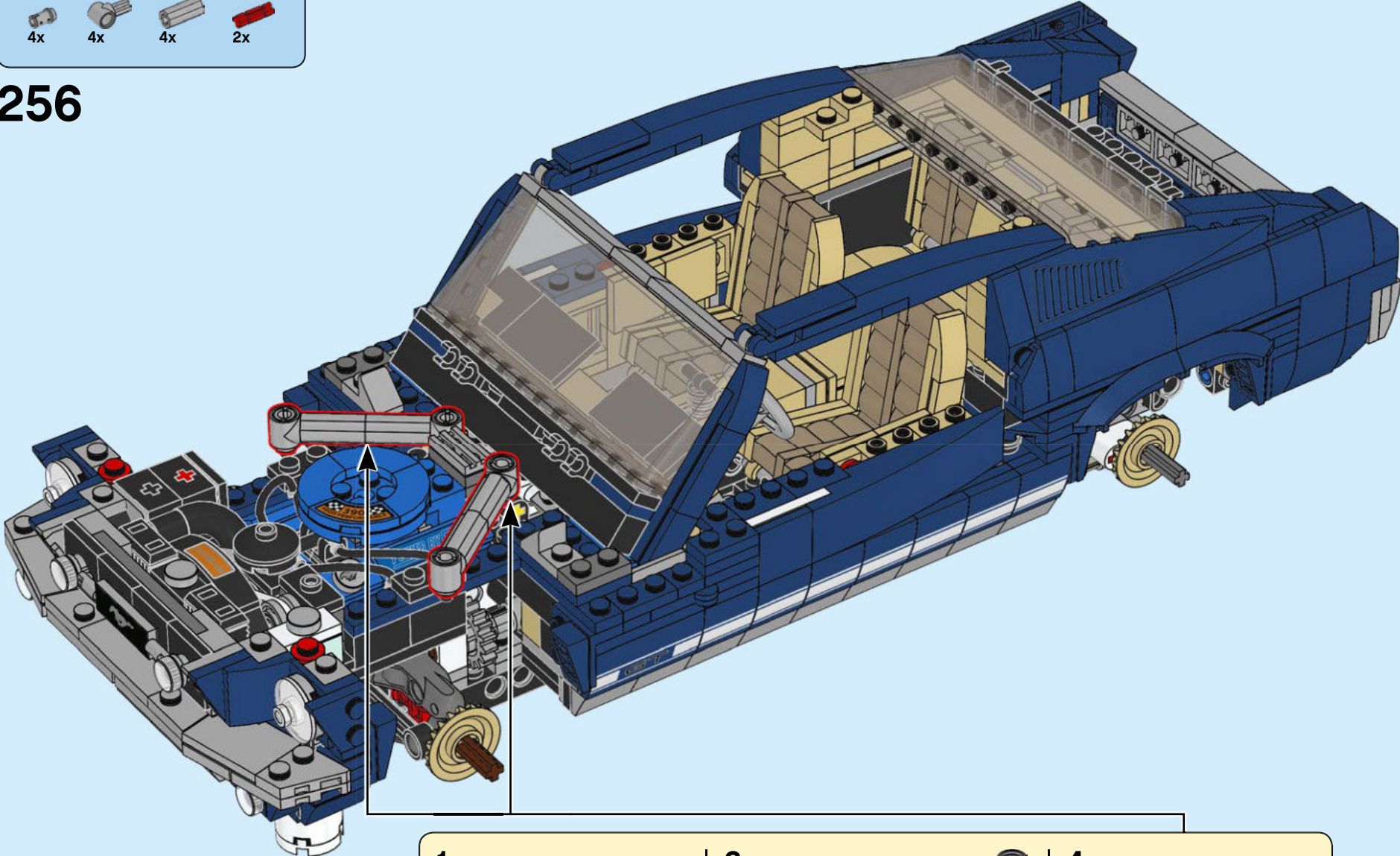

<p>1</p> <p>2</p>	<p>3</p>	<p>4</p> <p>2x</p>
-------------------	----------	--------------------

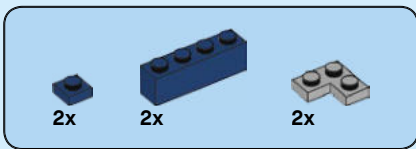

257

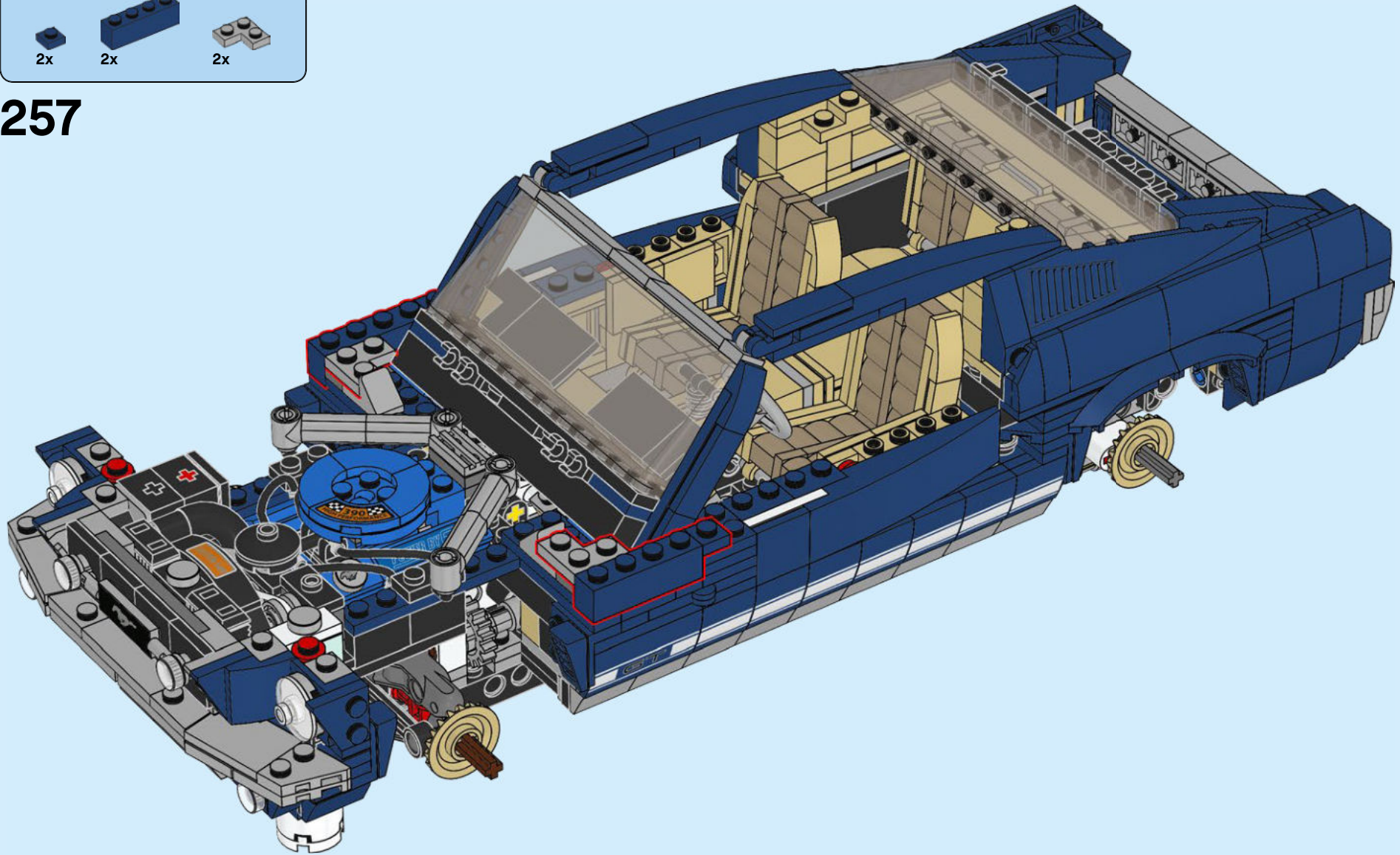

To mark its 50th birthday in 2014, Ford assembled a Mustang on the 86th floor observation deck of the Empire State Building.

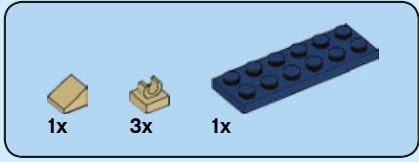
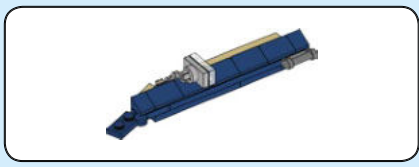

258

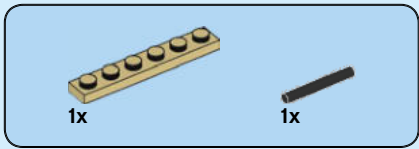
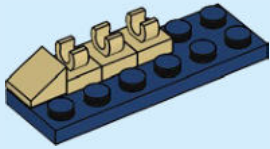

259

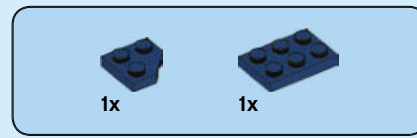
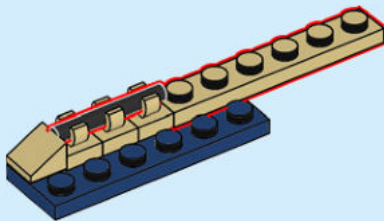

260

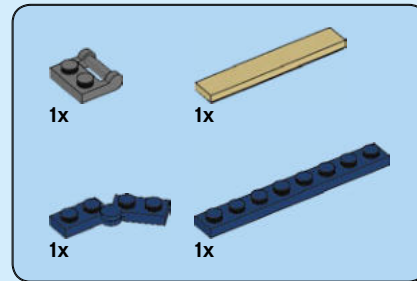
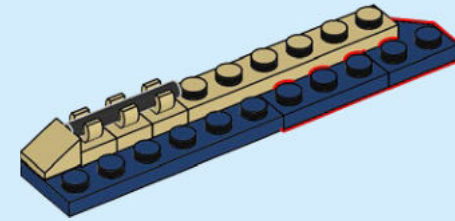

261

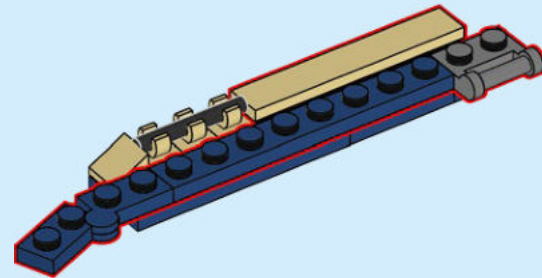



262

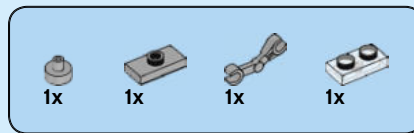
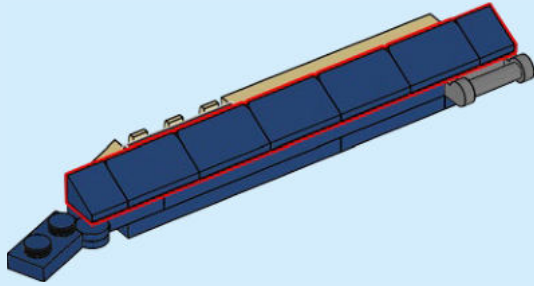

263

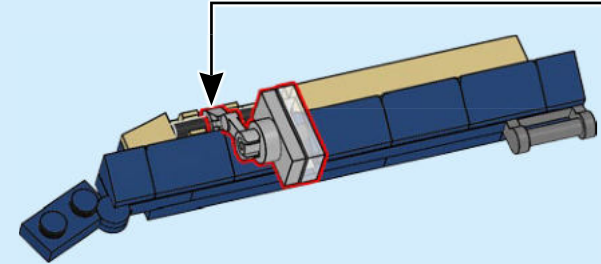
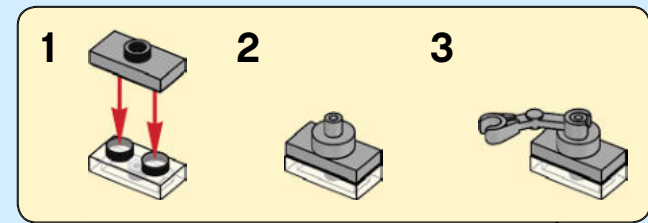

264

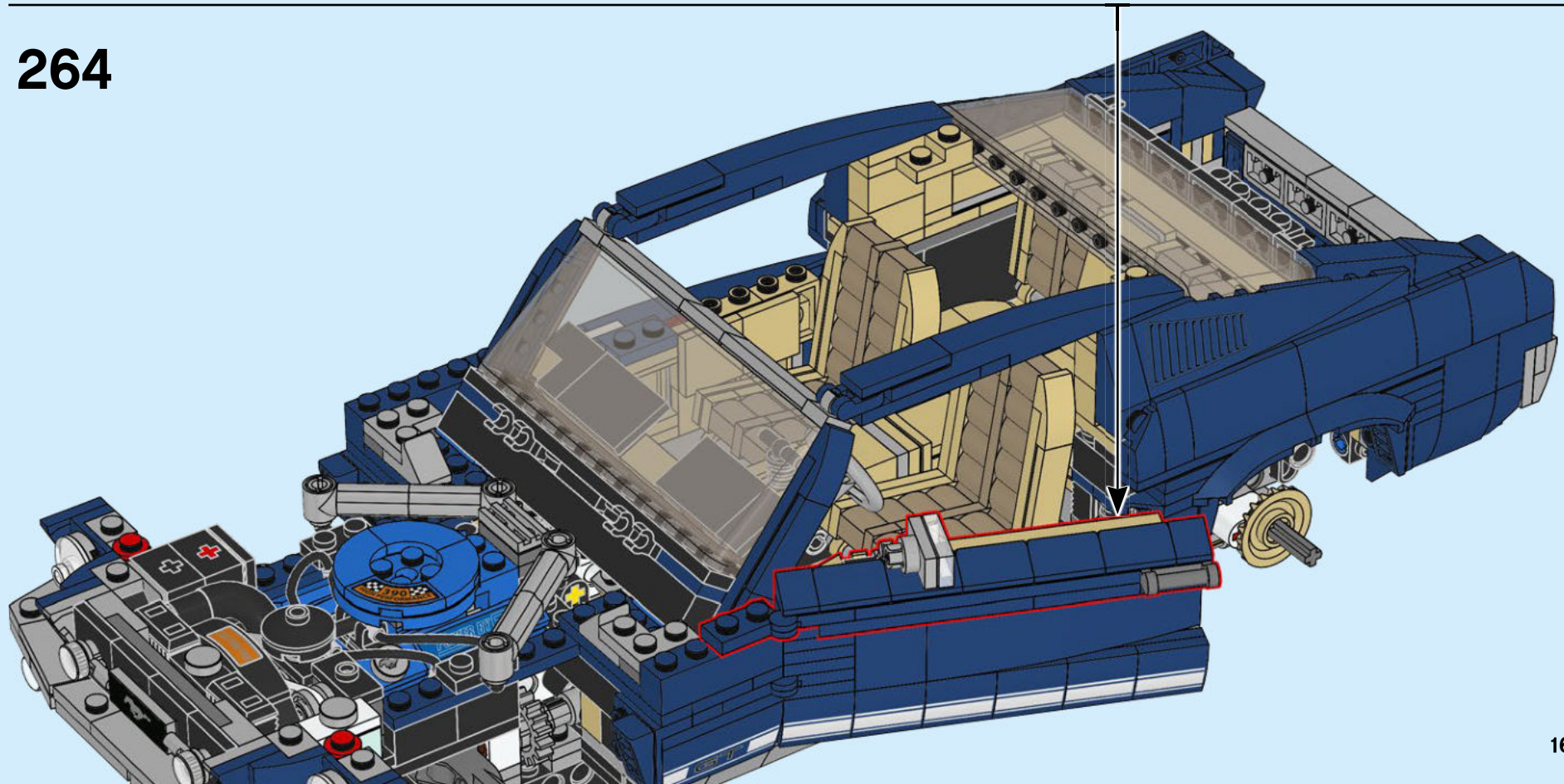

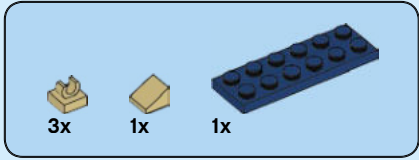
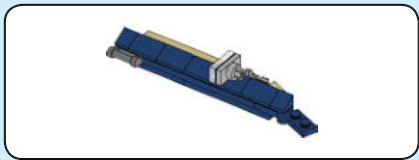

265

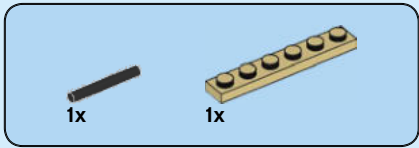
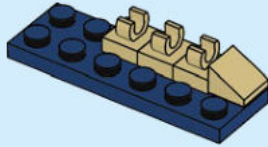

266

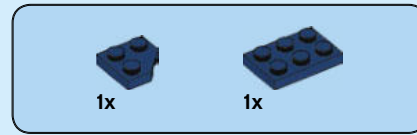
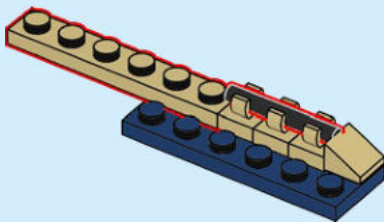

267

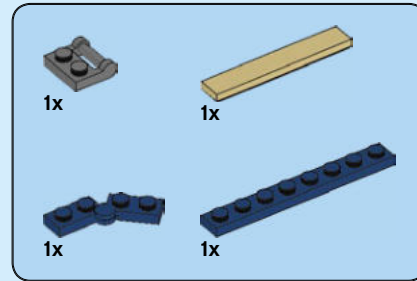
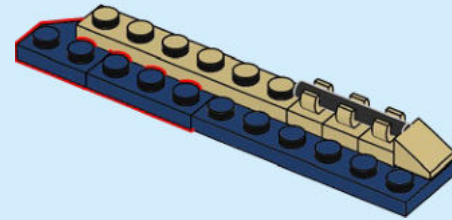

268

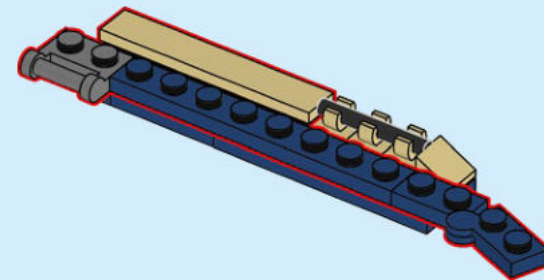



269

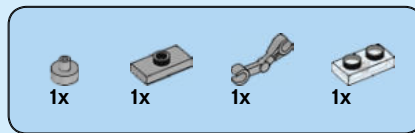
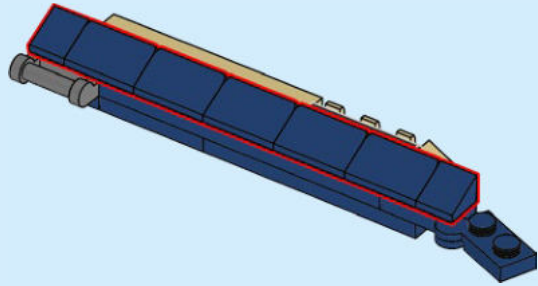

270

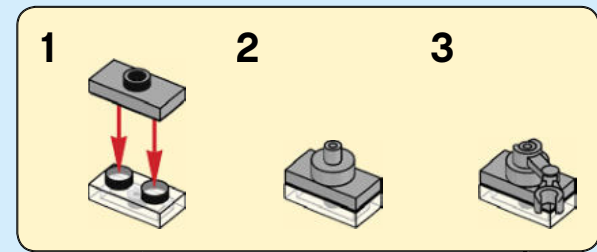
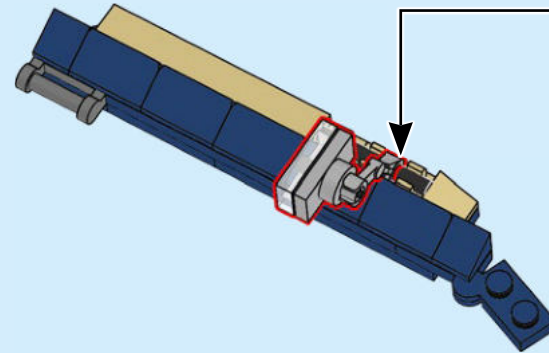

271

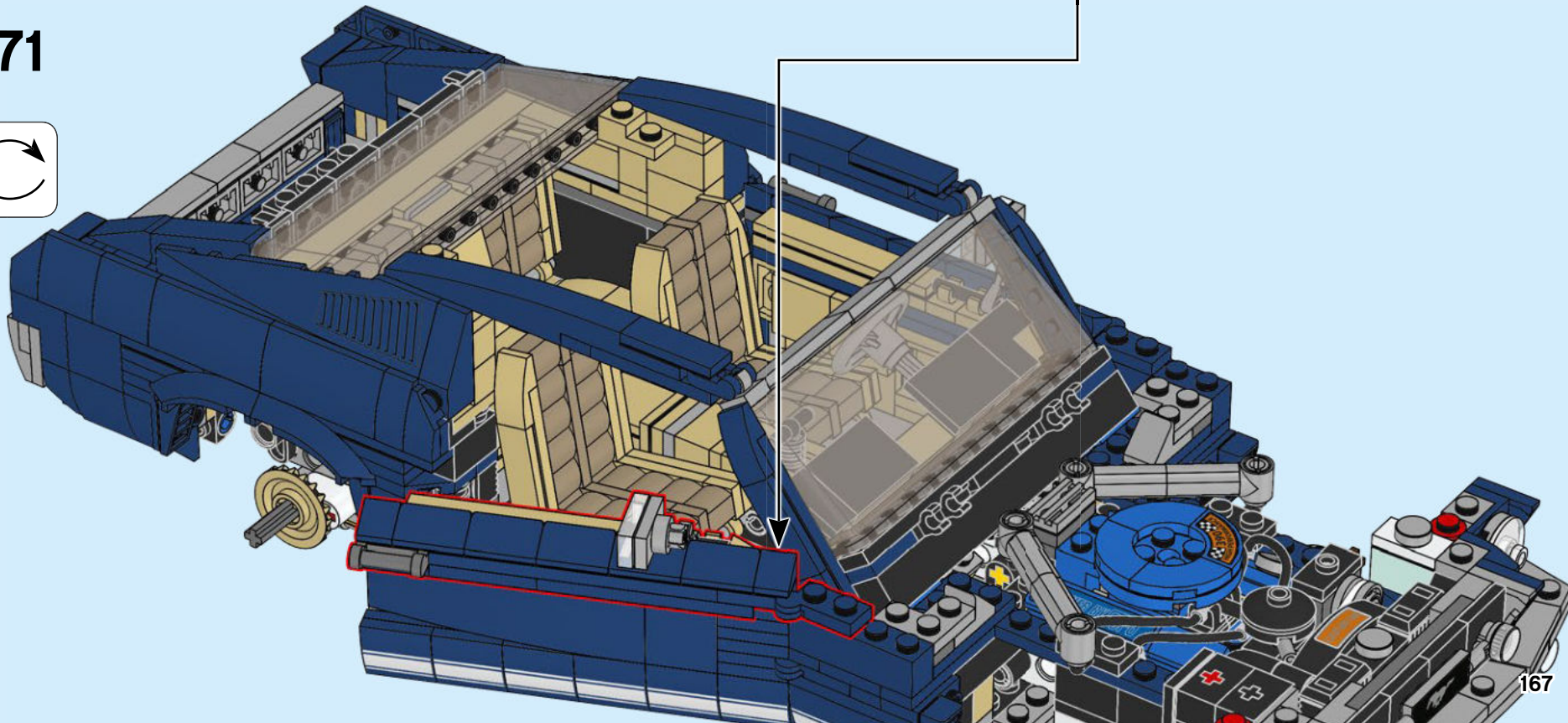
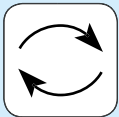

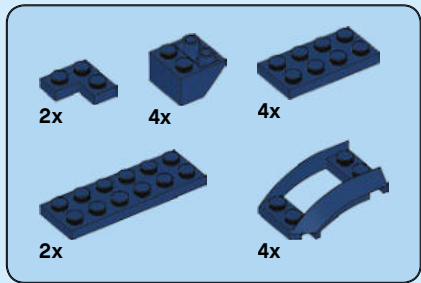

272

1

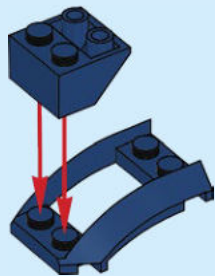

2



3

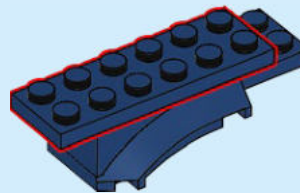

4

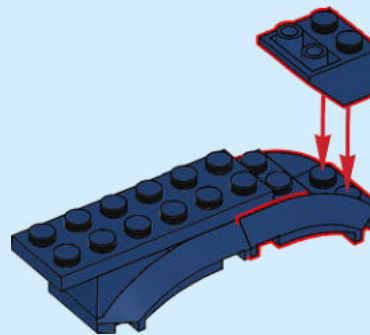

5

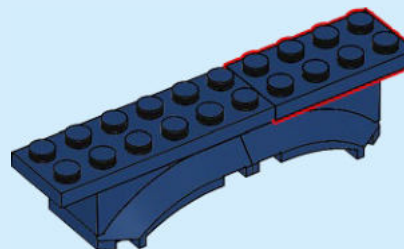

2x

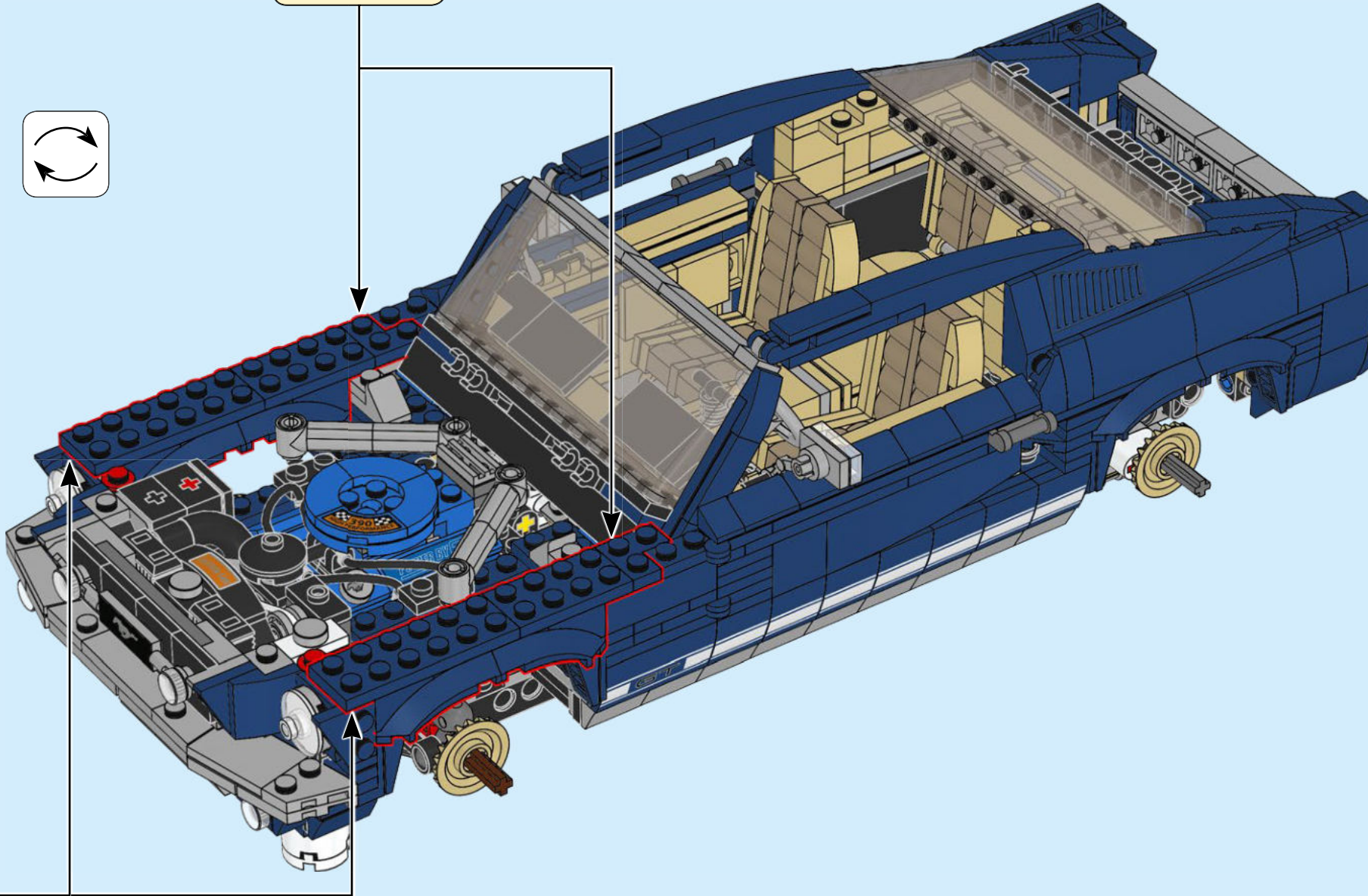
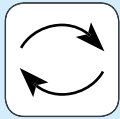

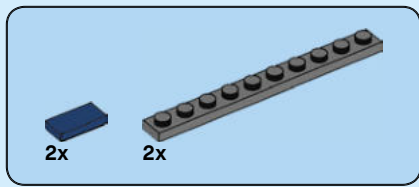

273

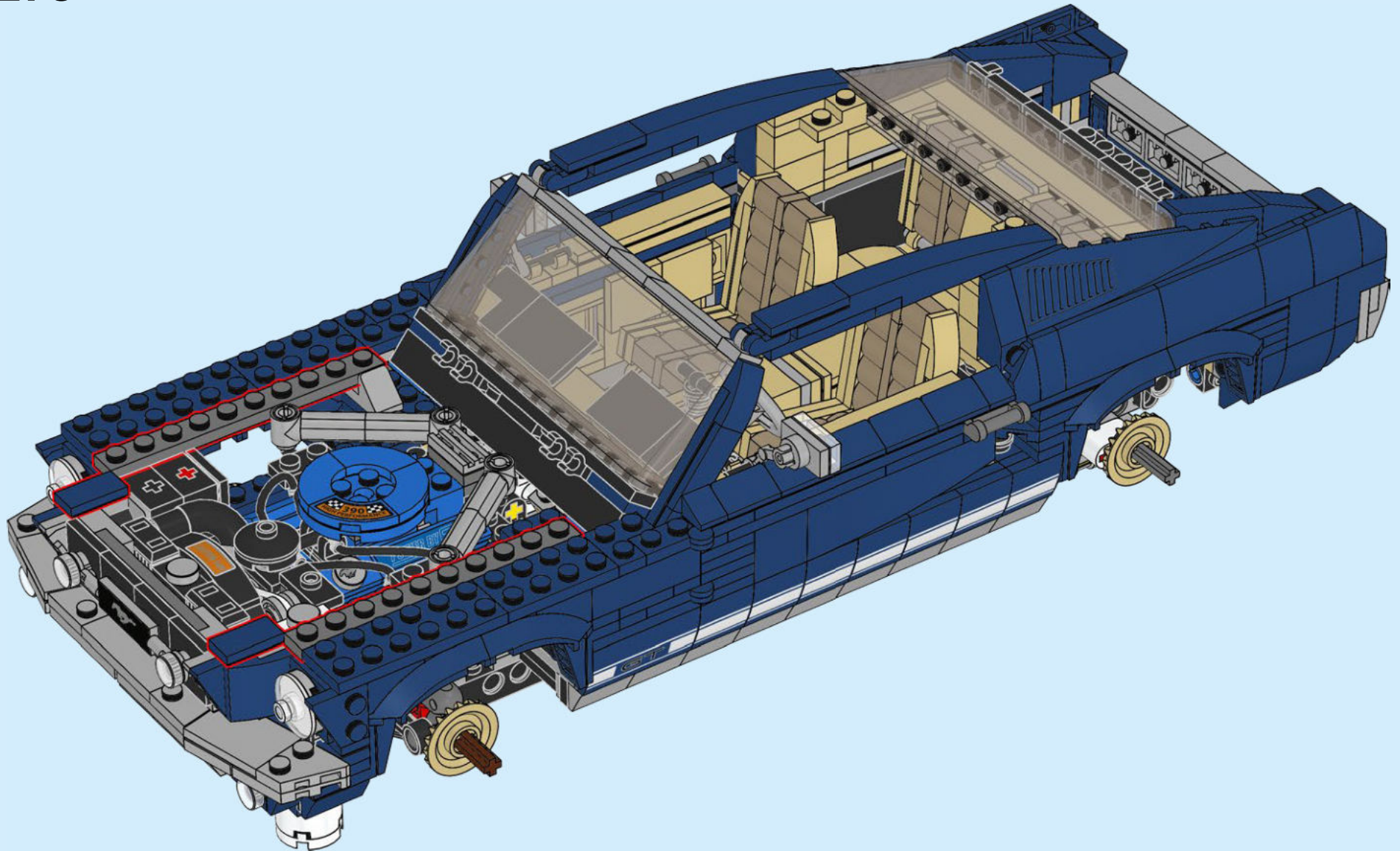

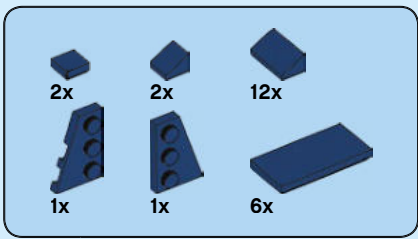

274

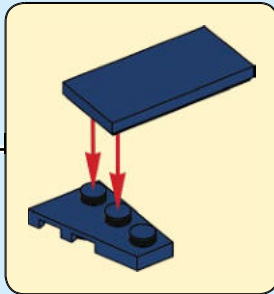
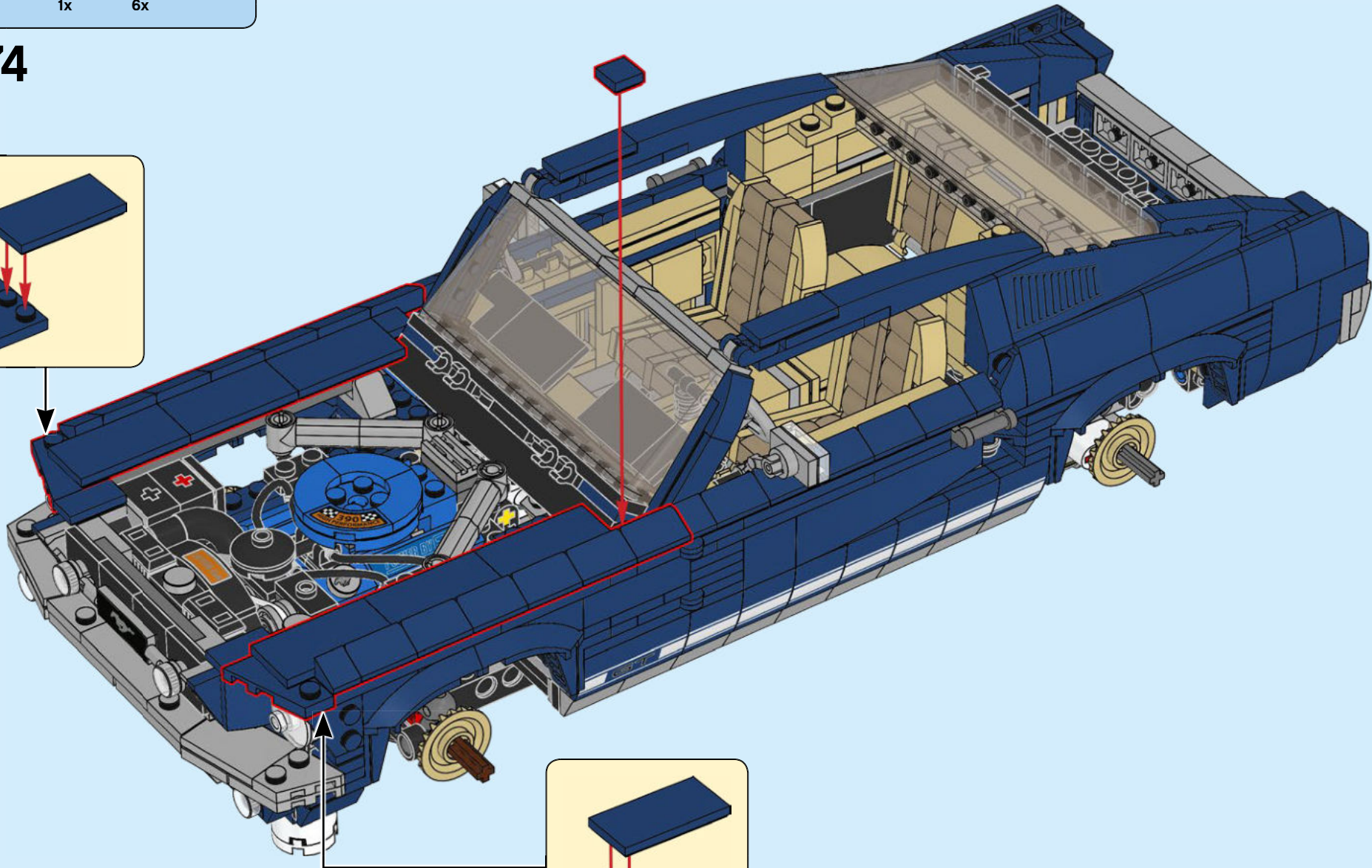
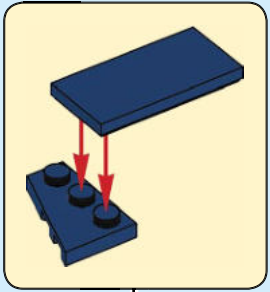

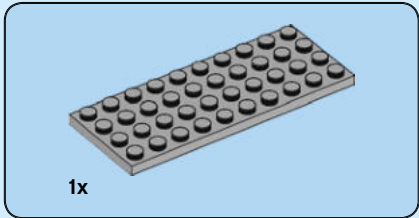
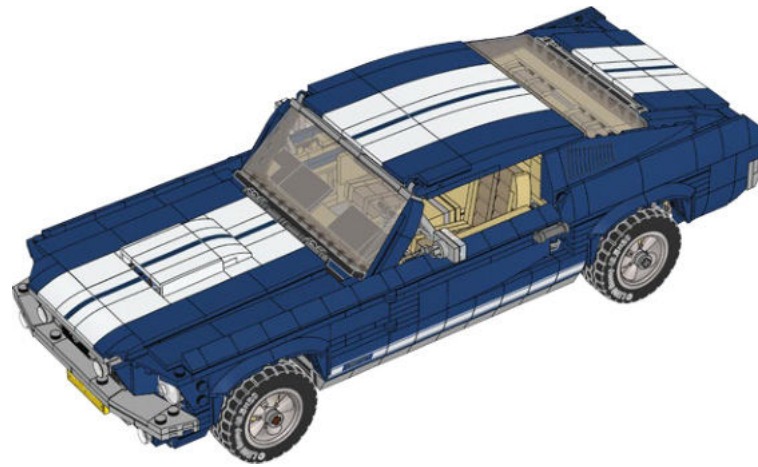
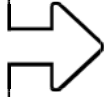

1x

275

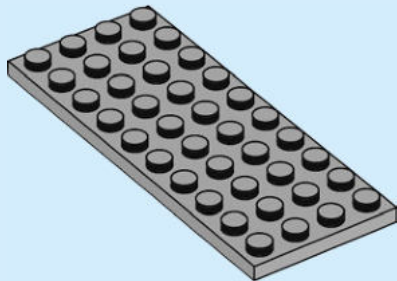

3x

4x

276

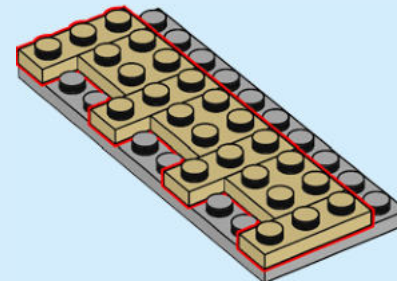

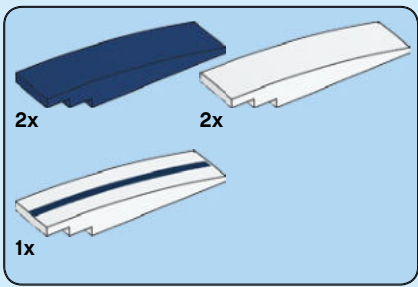

277

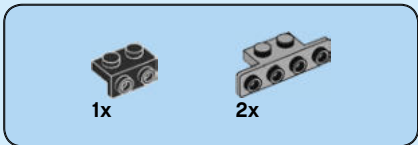
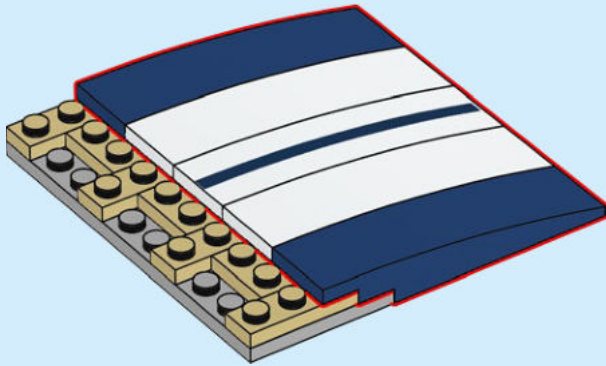

278

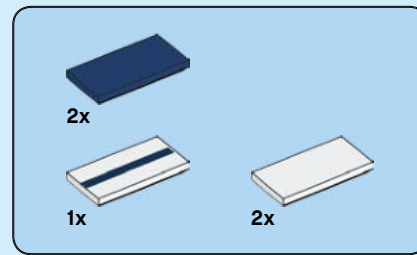
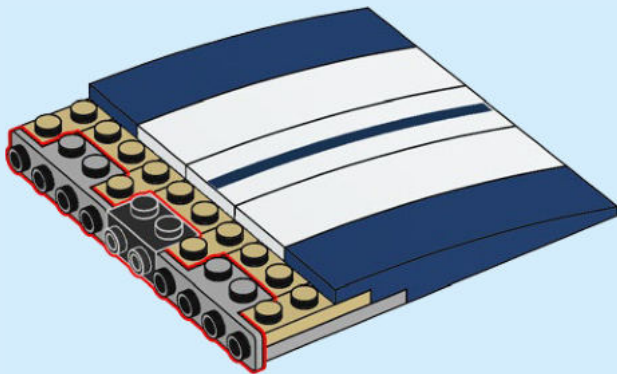

279

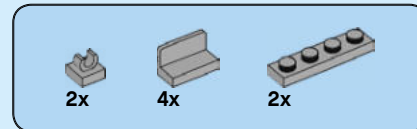
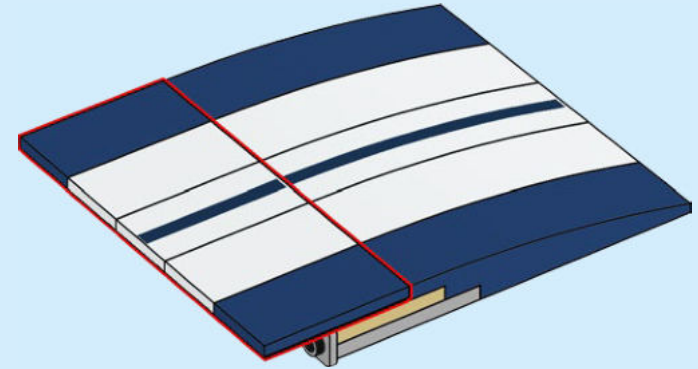

280

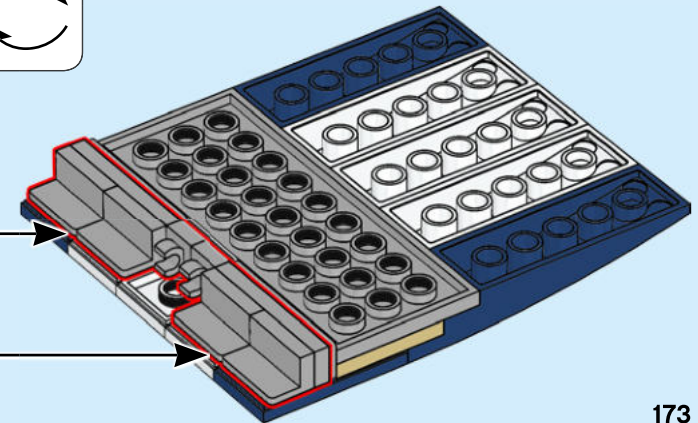
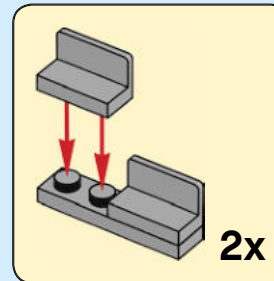
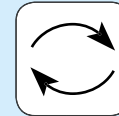

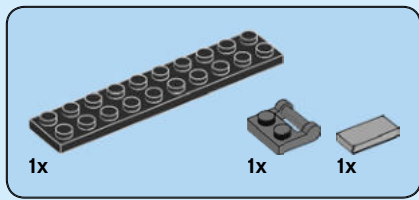

281

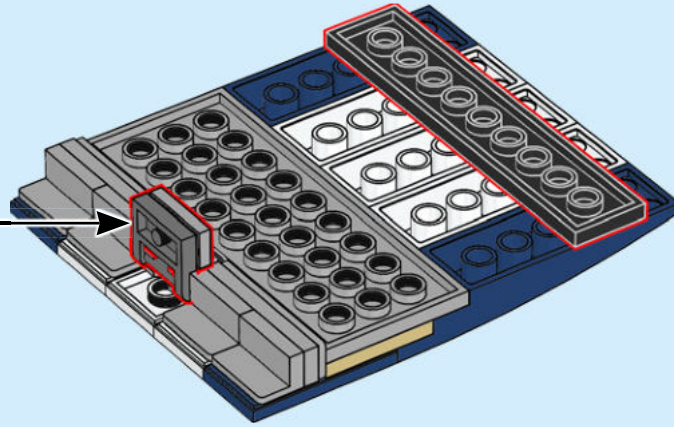
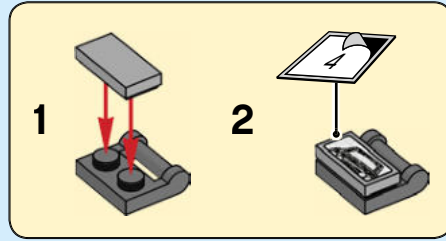

282

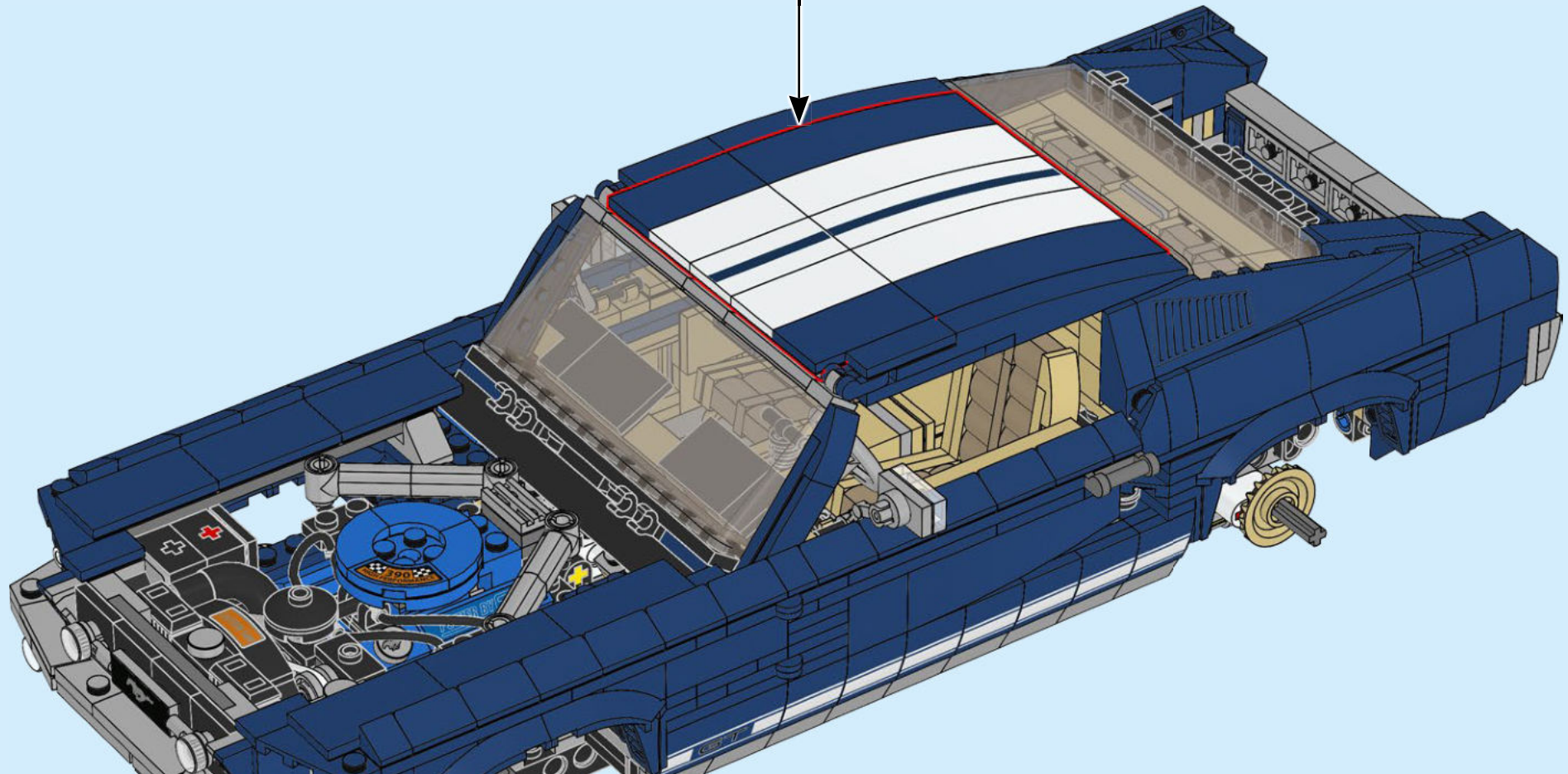

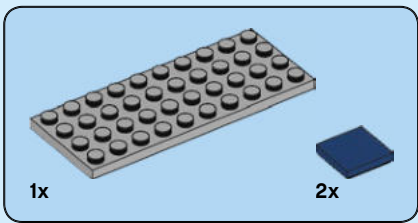

283

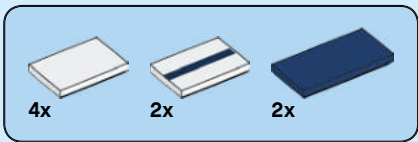
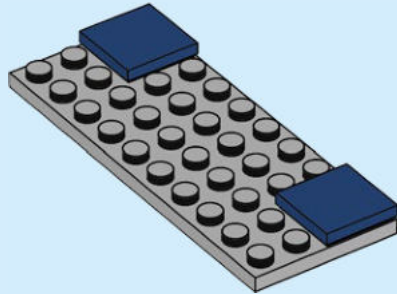

284

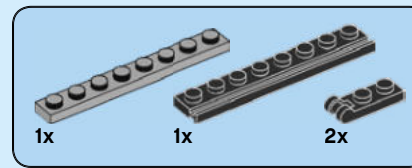
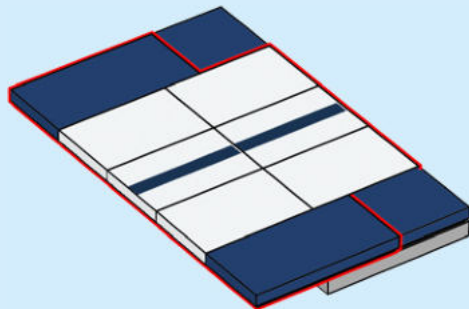

285

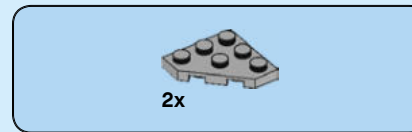
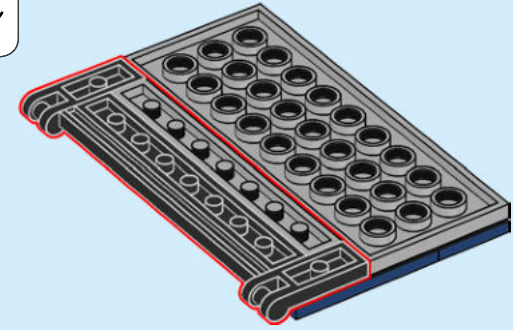
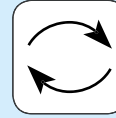

286

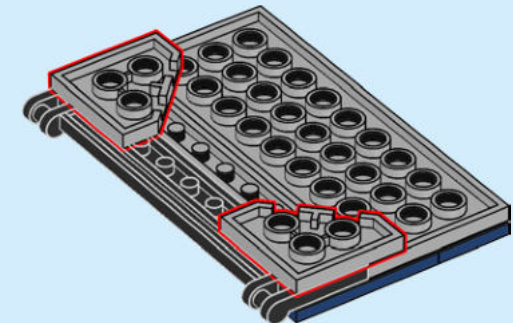

287

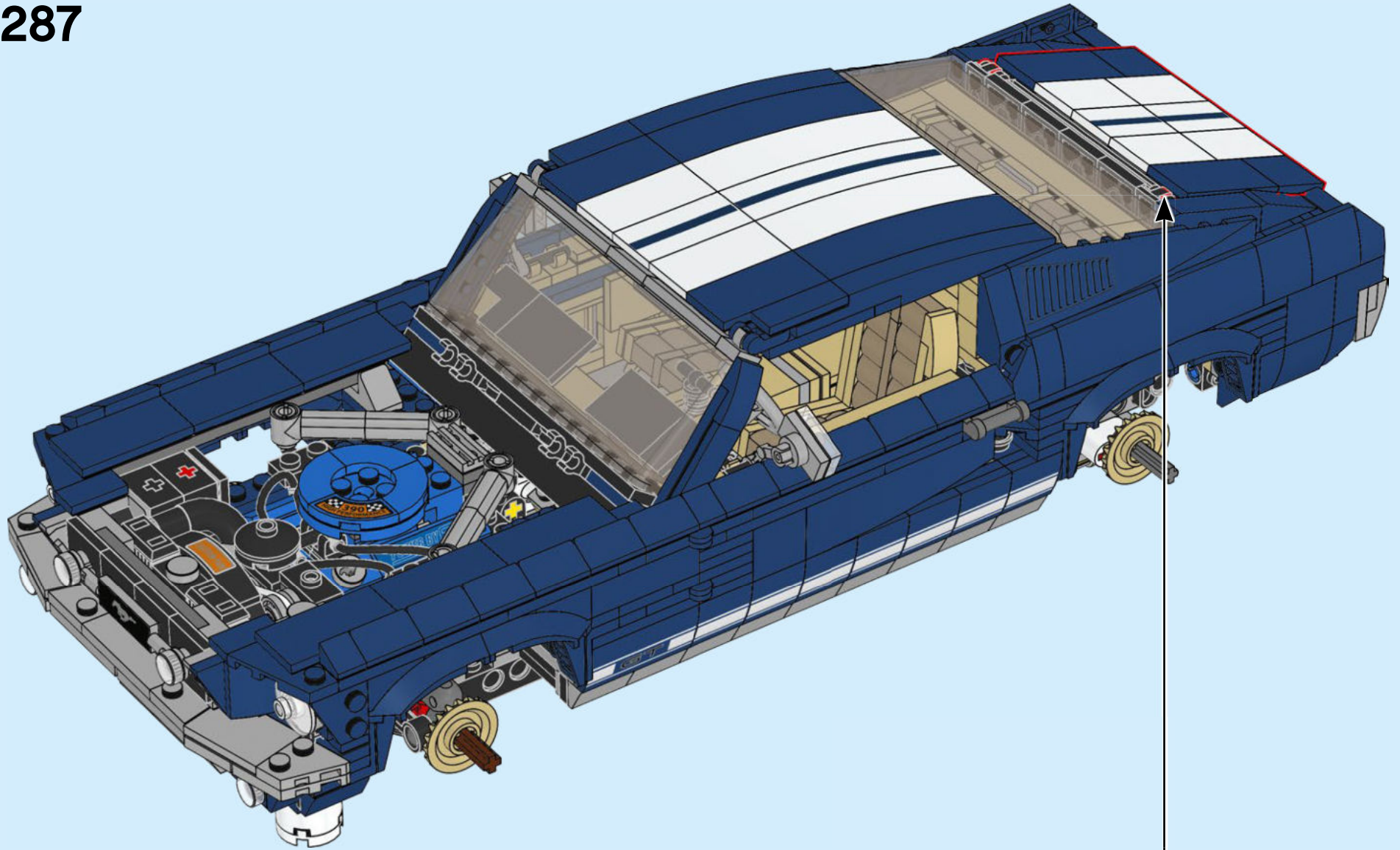

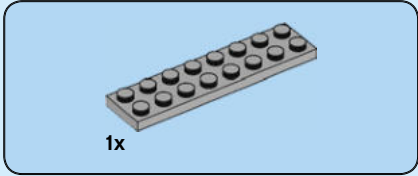
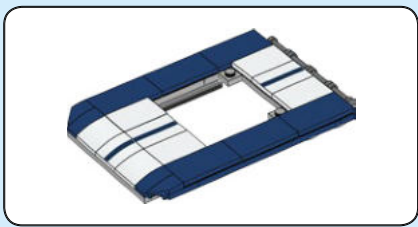

288

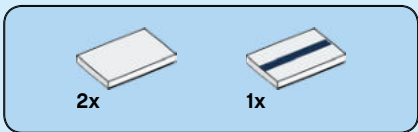
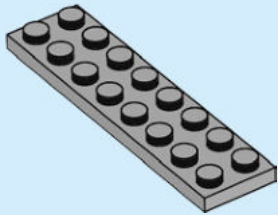

289

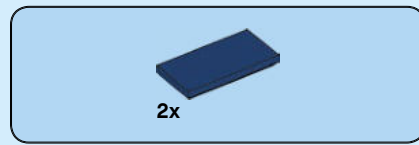
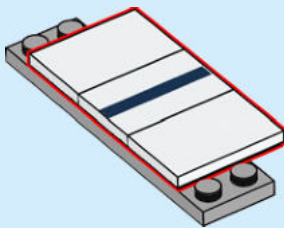

290

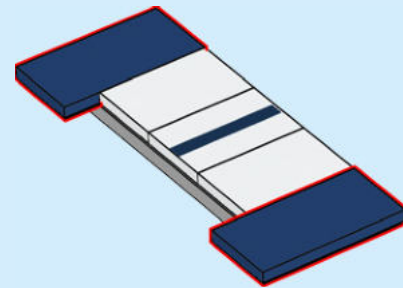

291

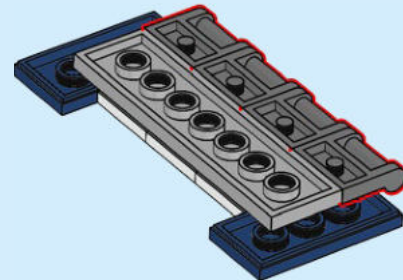
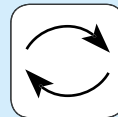

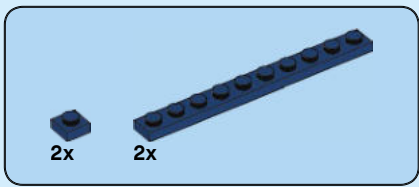

292

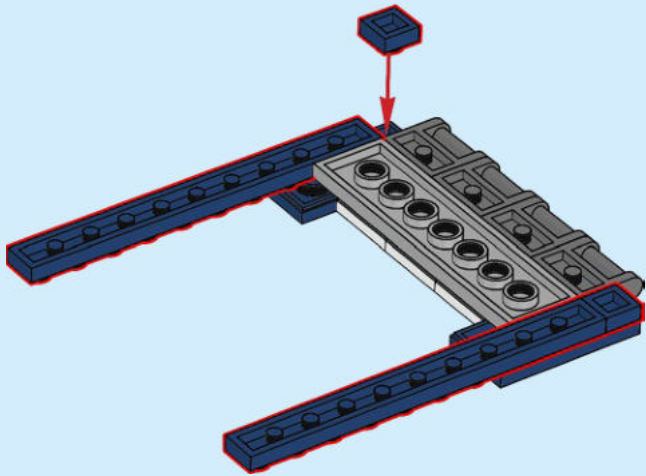

293

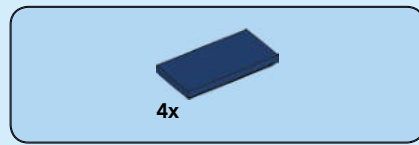
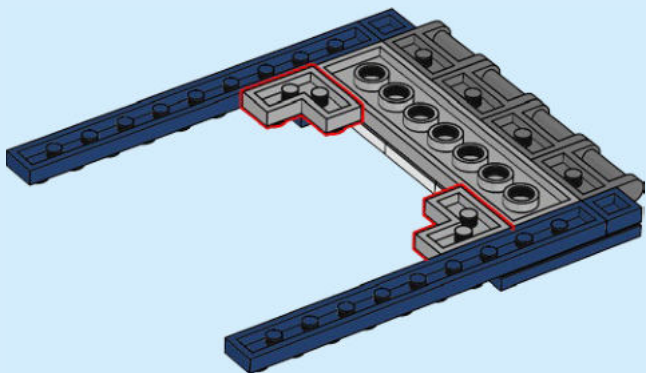

294

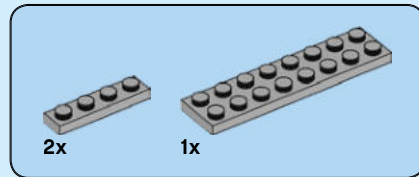
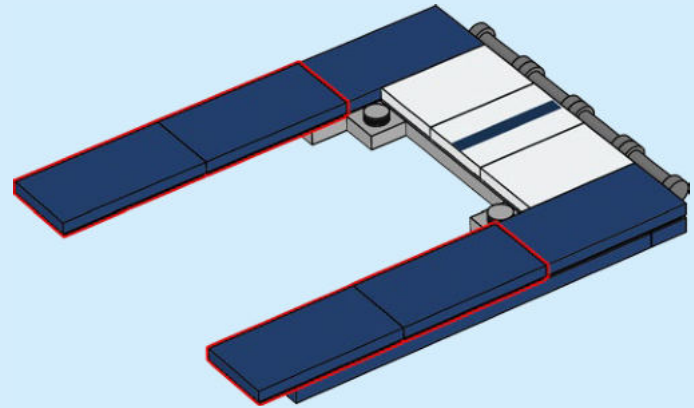
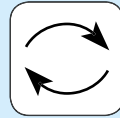

295

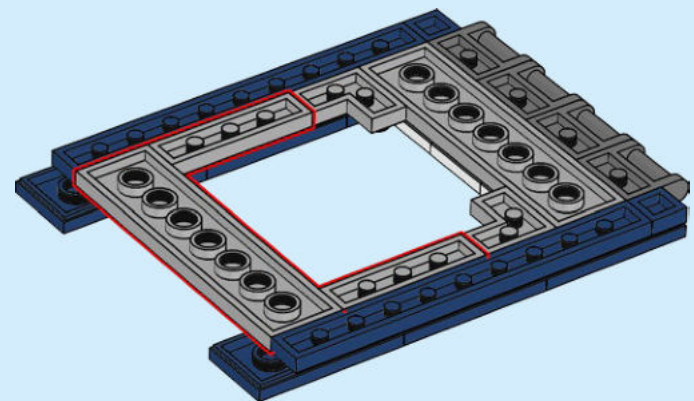
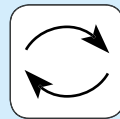



296

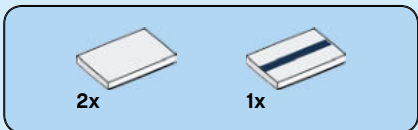
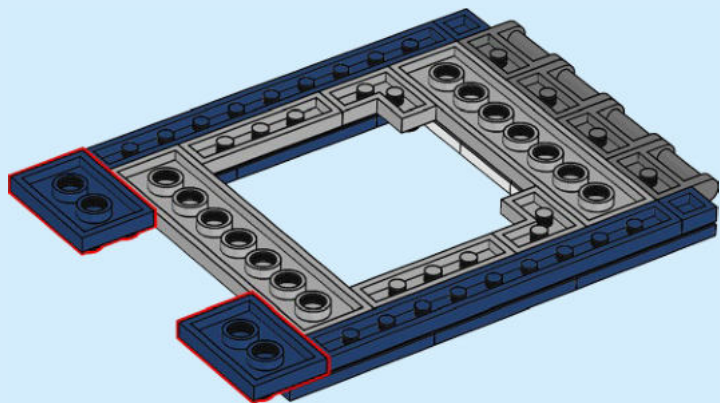

297

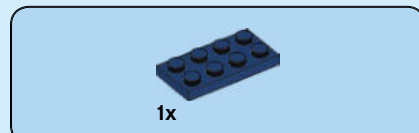
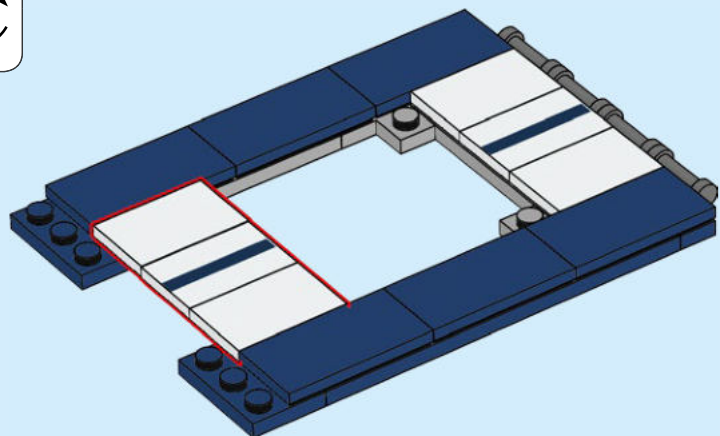
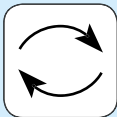

298

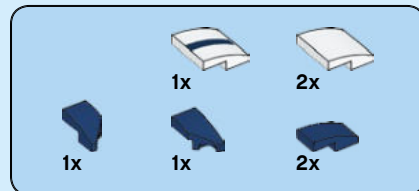
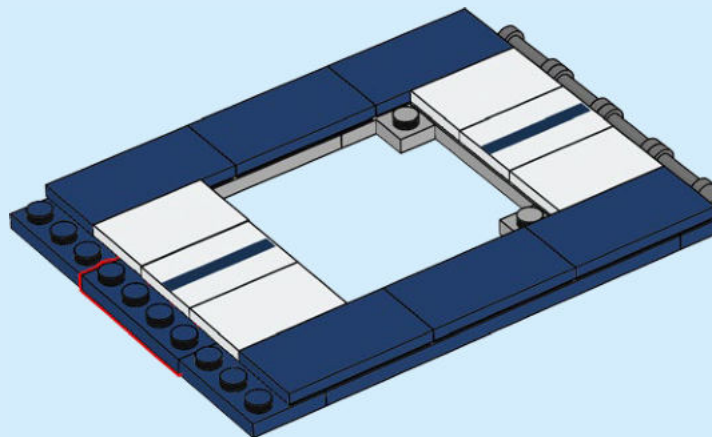

299

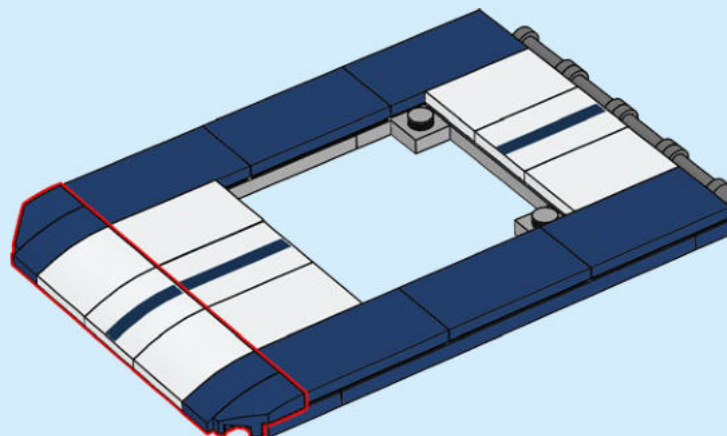

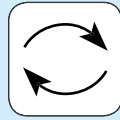
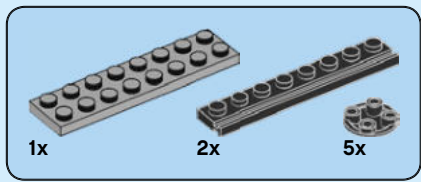

300

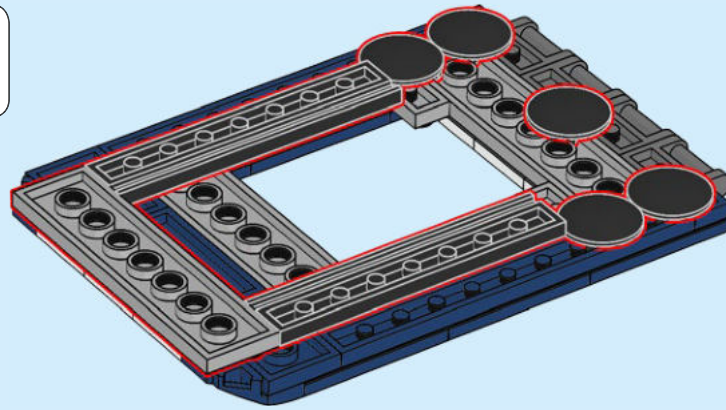

301

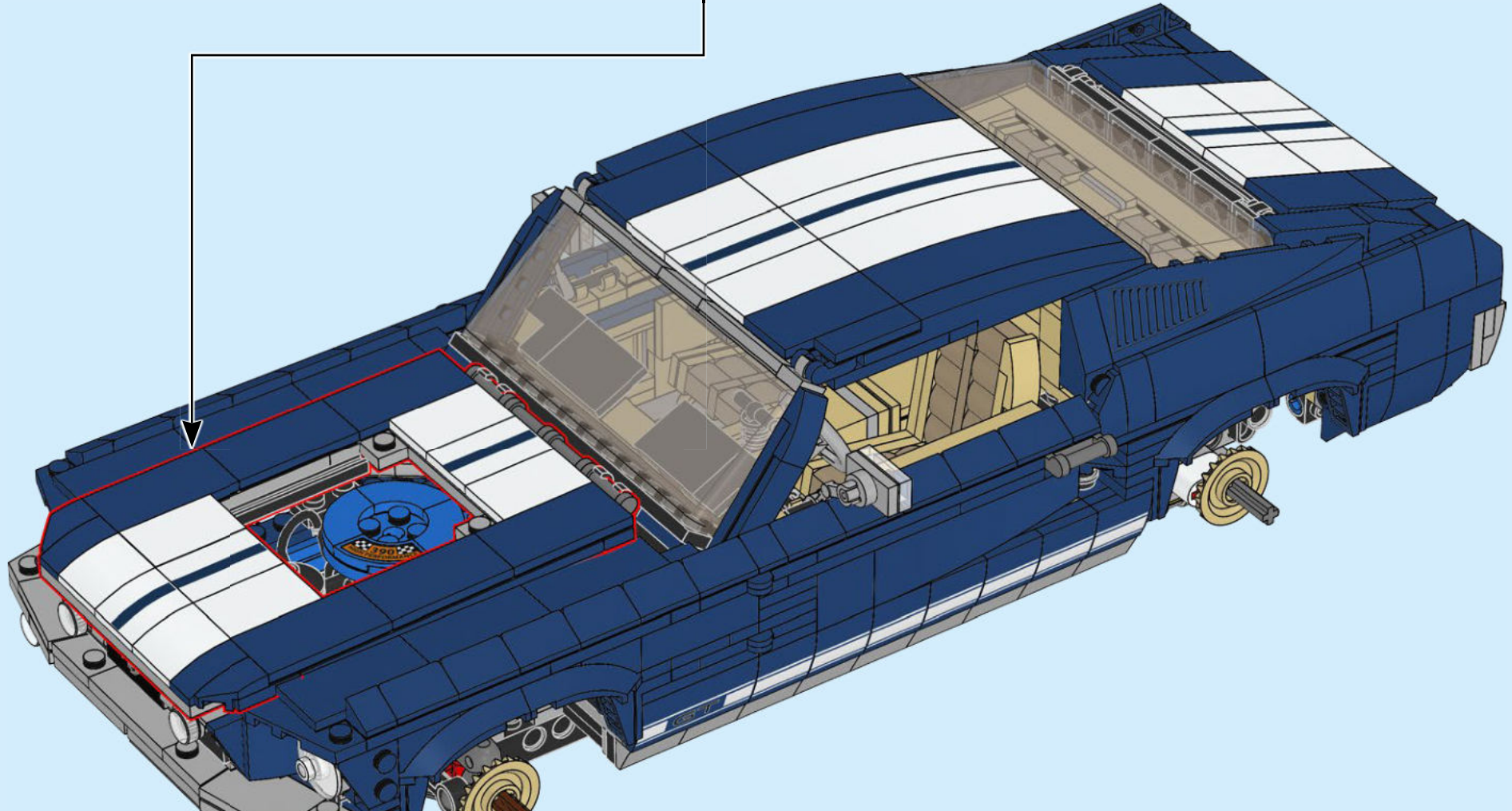

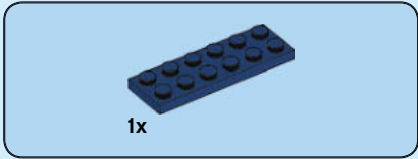

302



303

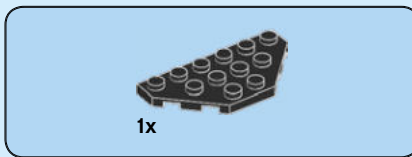
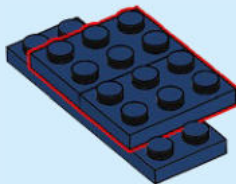

304

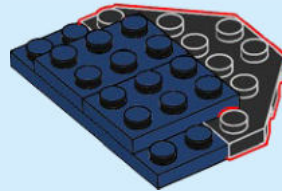

305

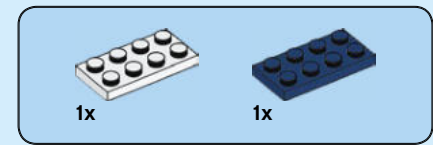
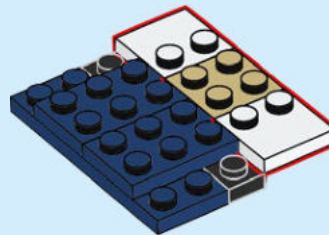

306

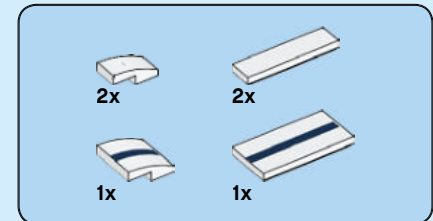
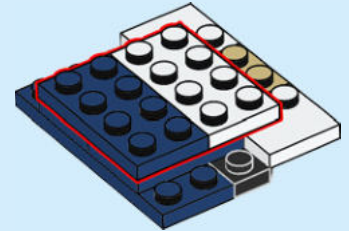

307

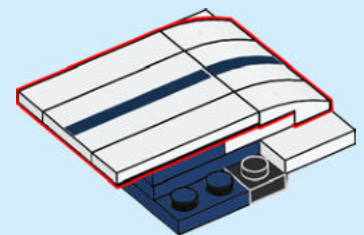

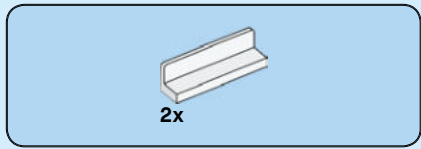

308

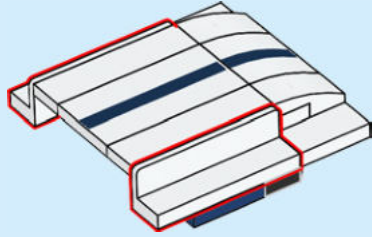

309

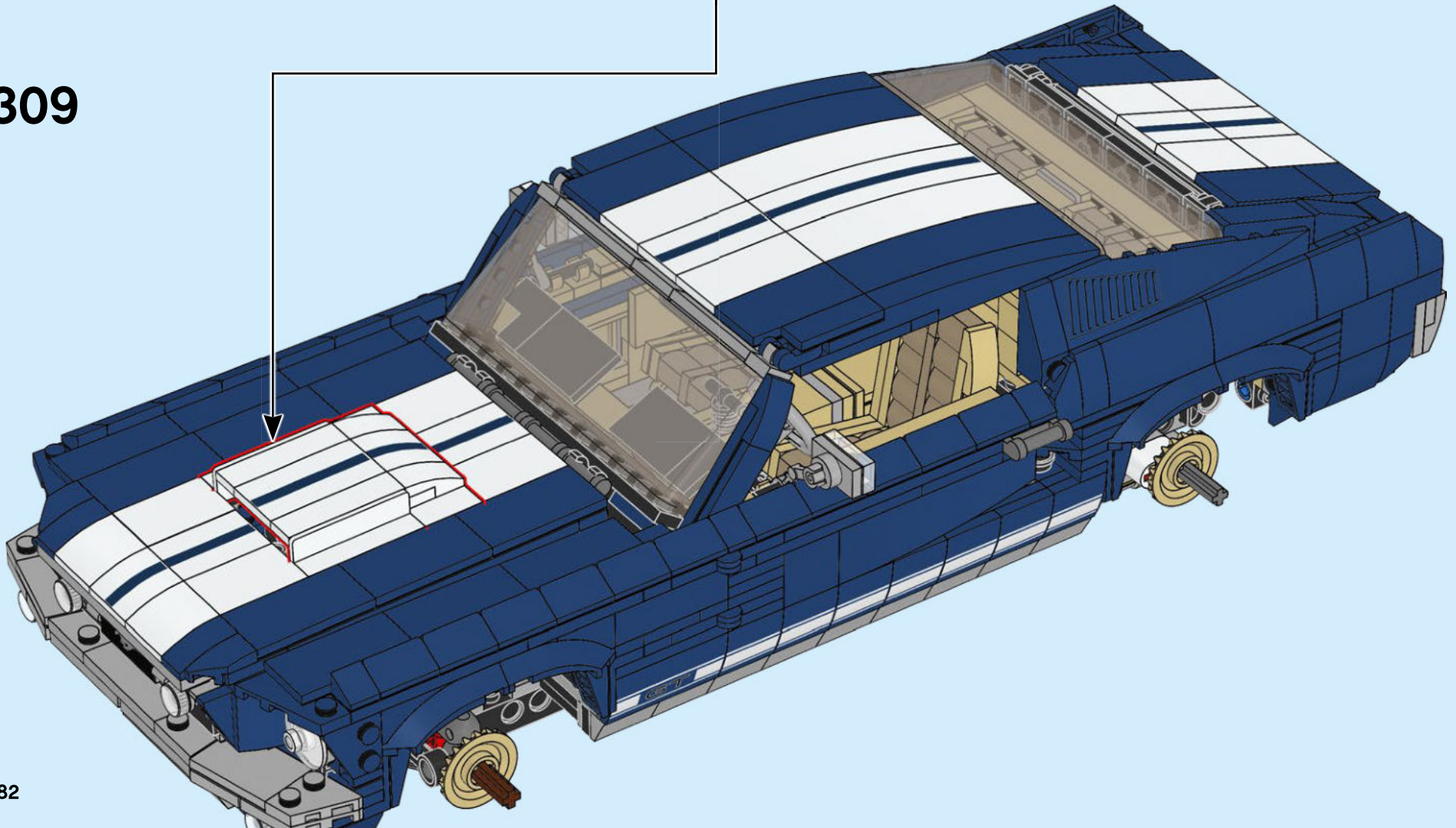

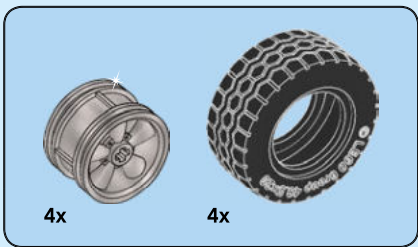

310

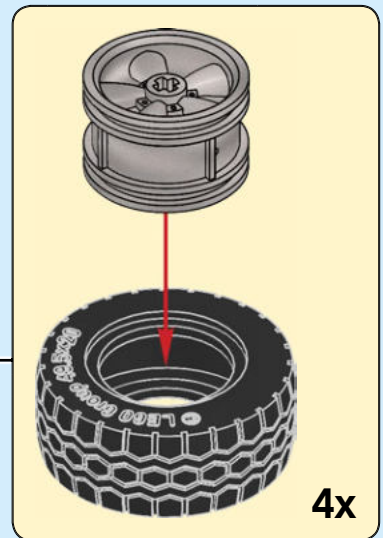
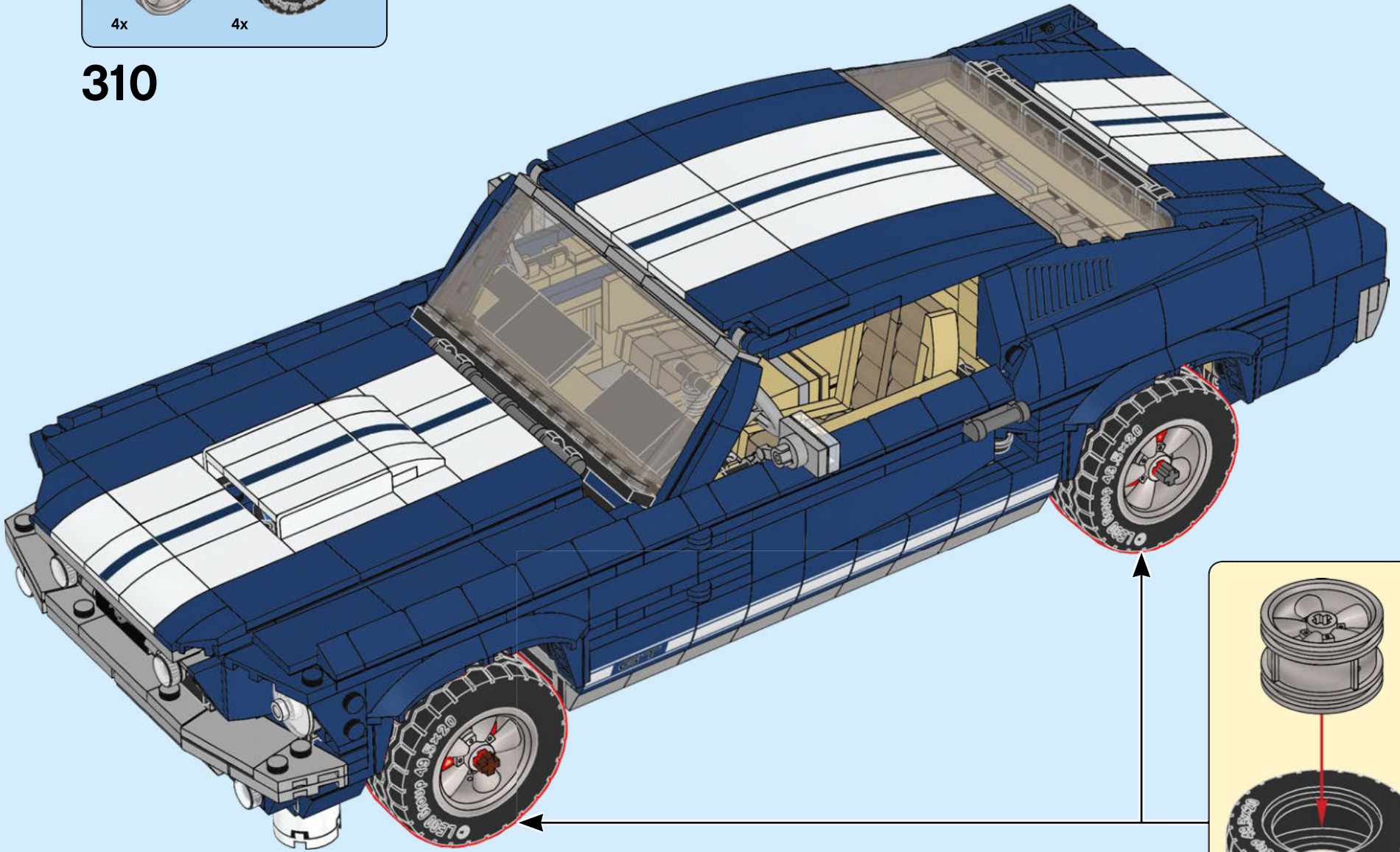



4x

311

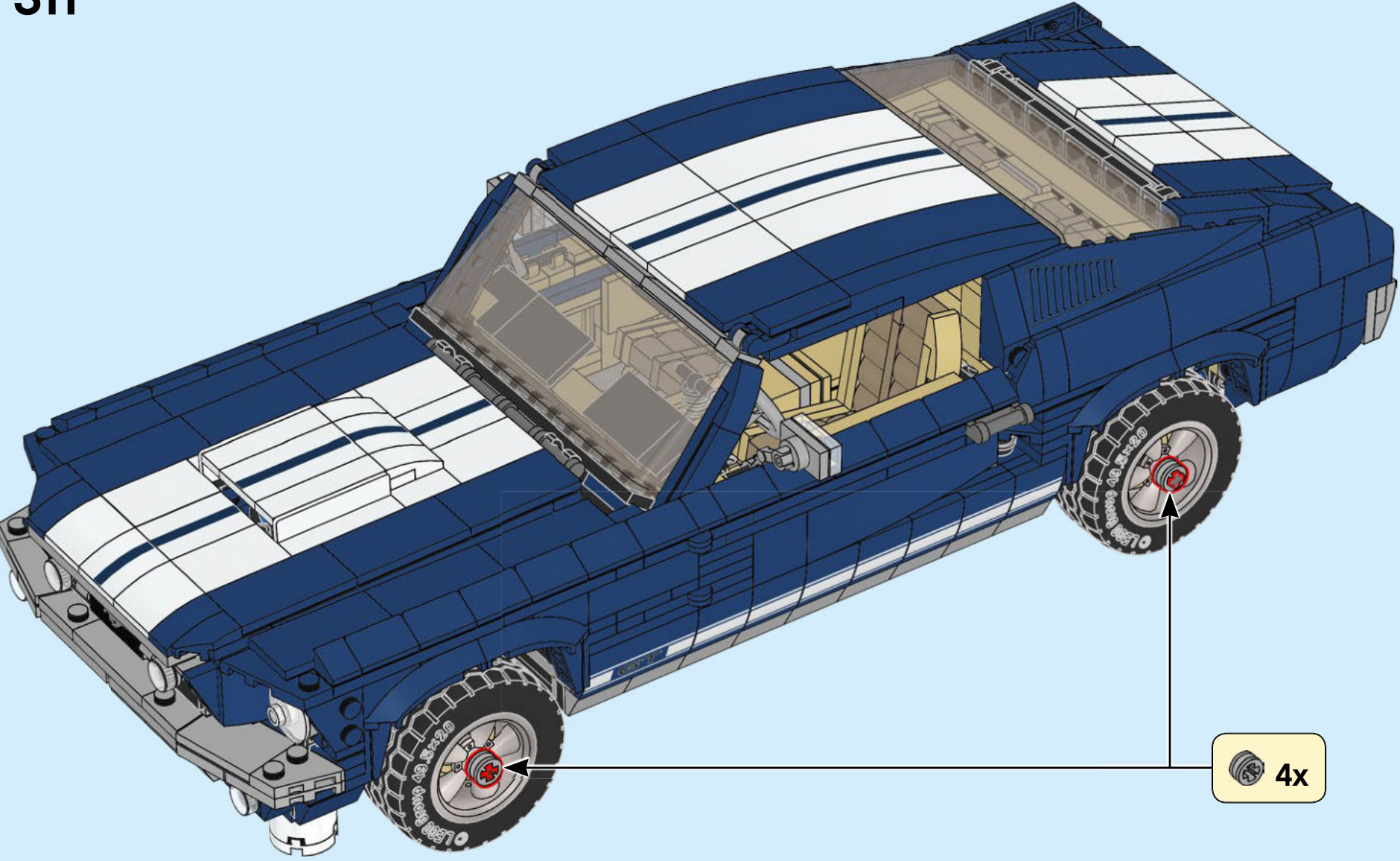

4x

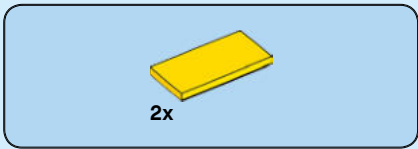

312

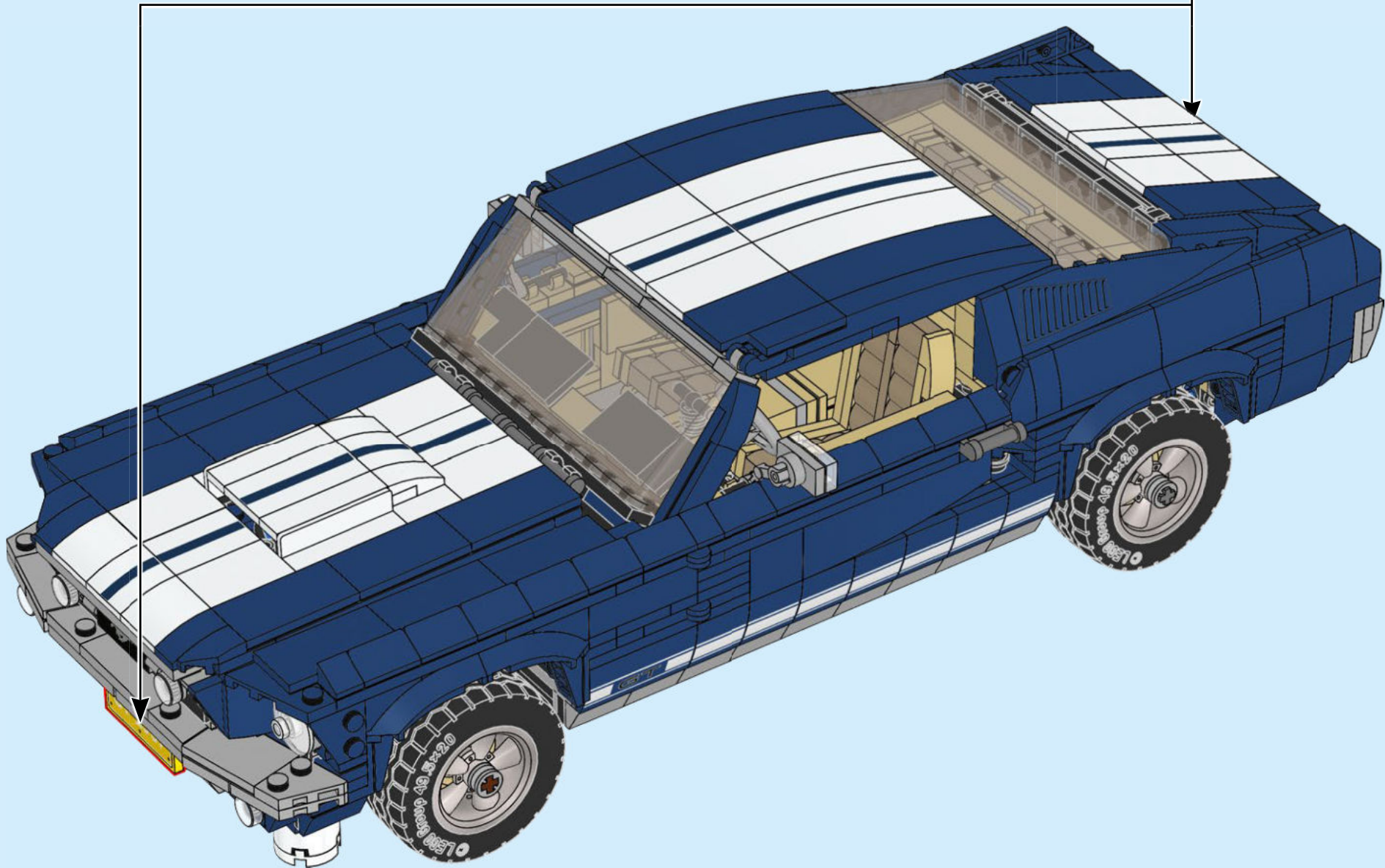
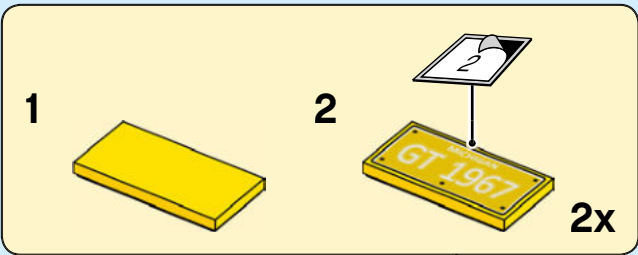

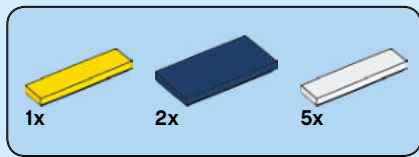

The first Mustang sold was only ever intended to be a demo model - but Eastern Airlines pilot Stanley Tucker convinced a dealer in Canada to sell it to him. Ford were able to reacquire the car after two years... in exchange for the millionth Mustang made.

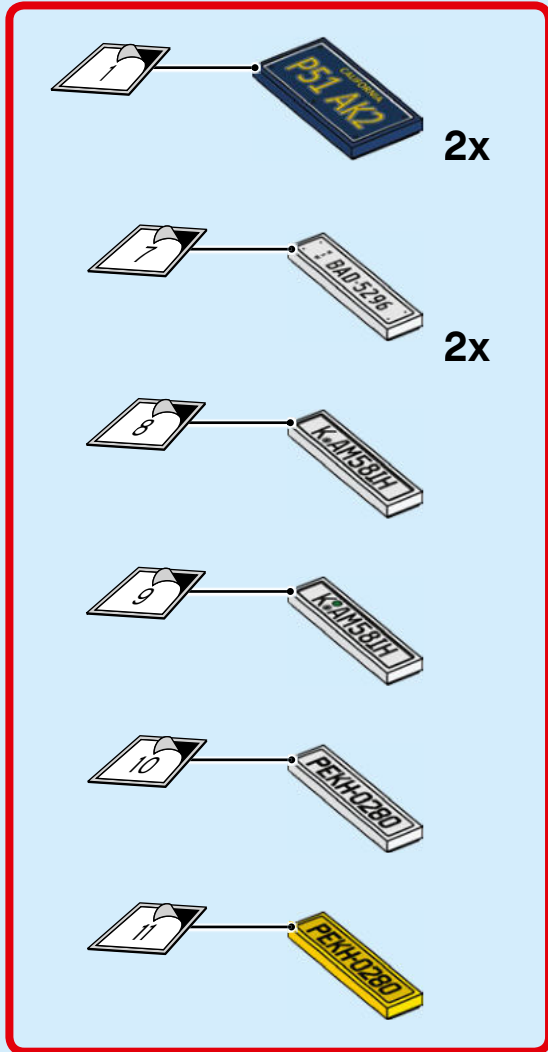

313

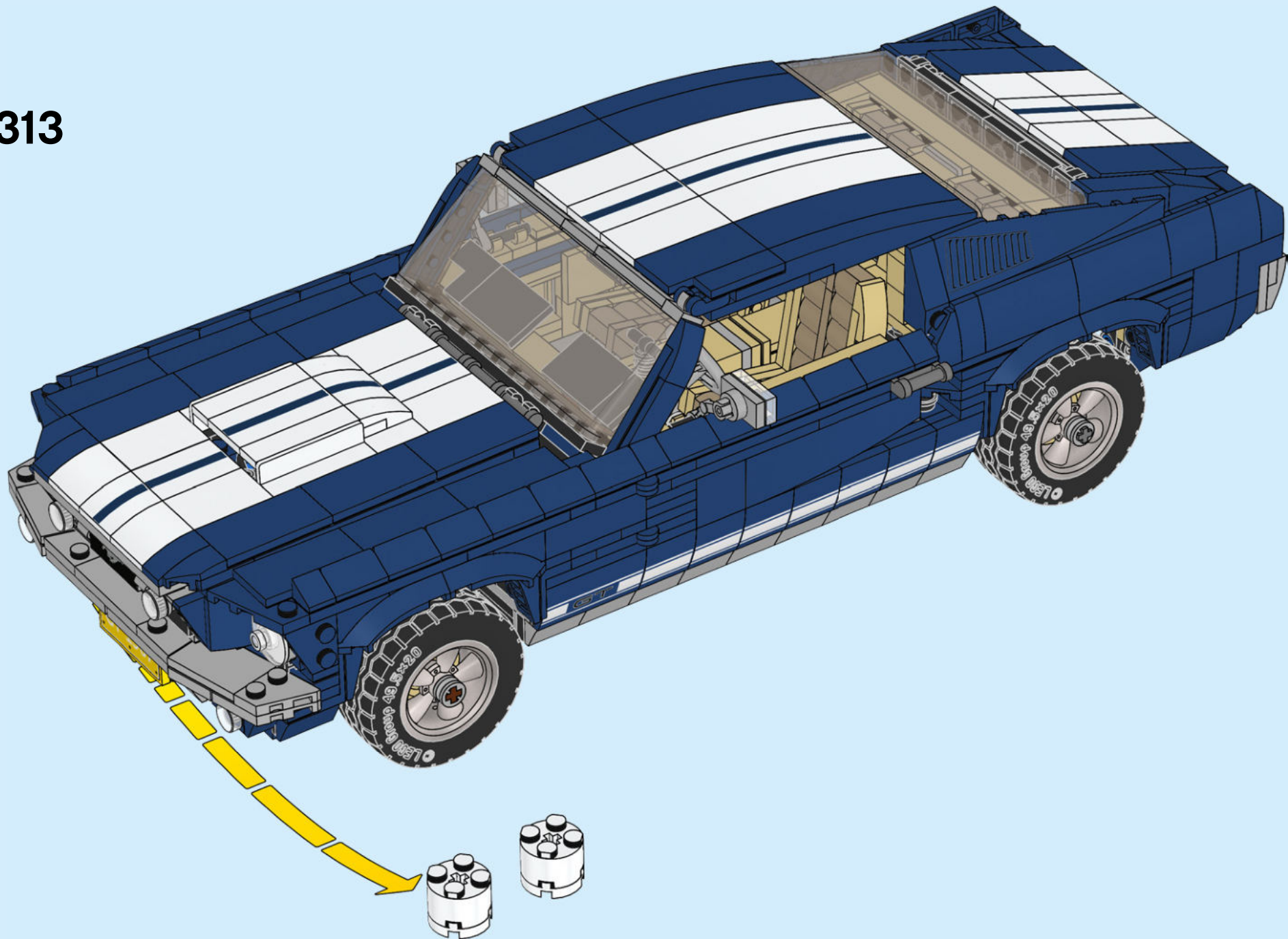

POWER UP YOUR MUSTANG!



Six ways to customize your Mustang

1. Adjustable rear suspension
2. Shorty exhaust headers
3. Supercharger with scoop intake
4. Front splitter
5. Rear spoiler
6. Nitrous oxide tank



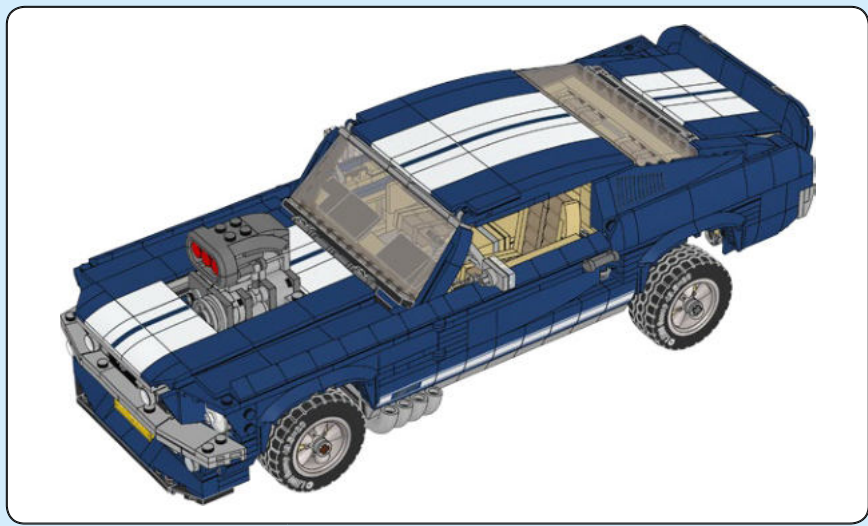

1

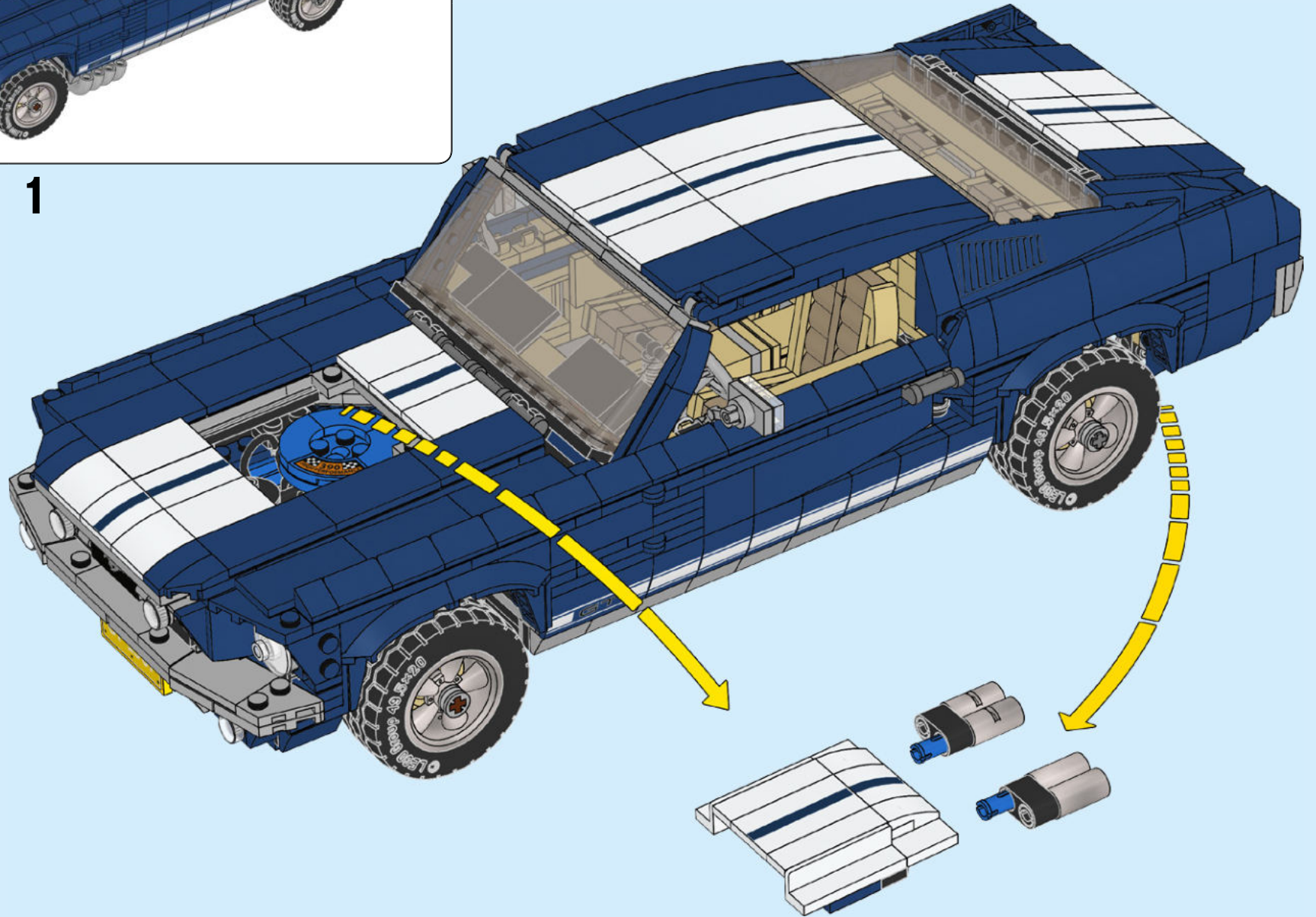

2

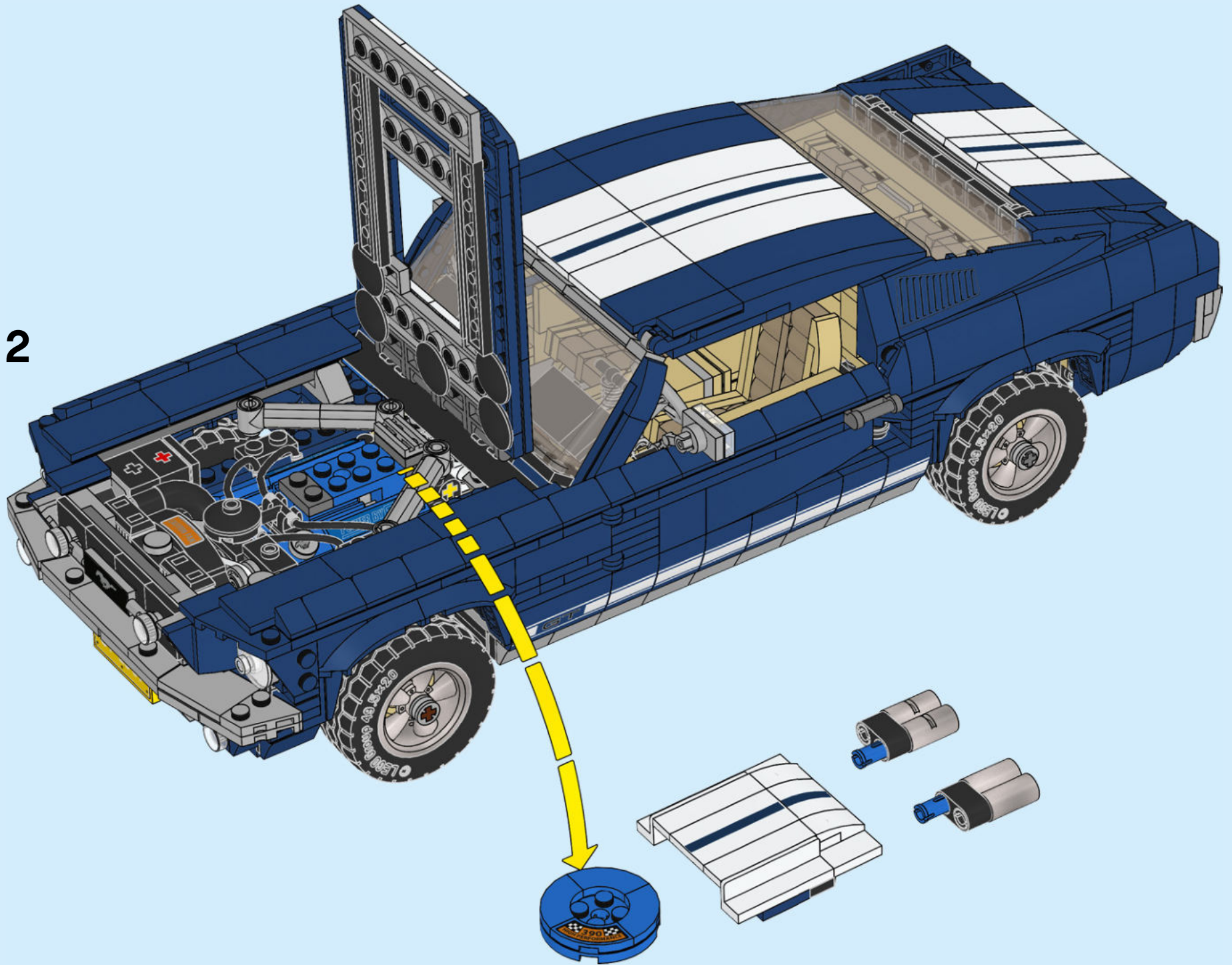

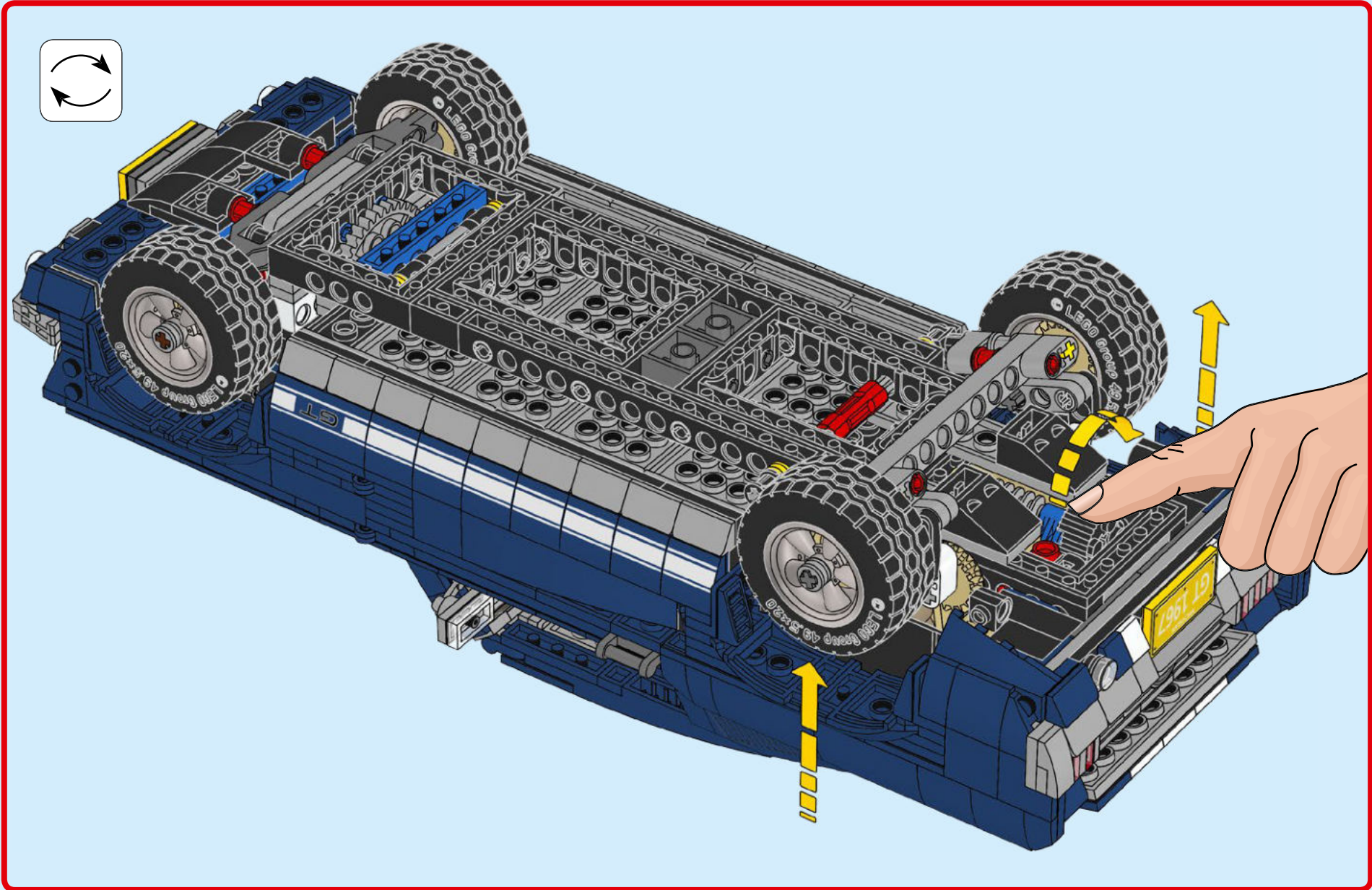

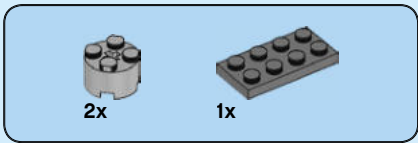
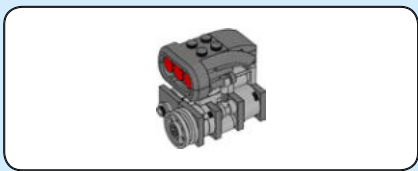

3

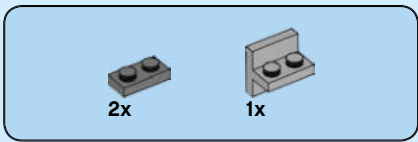
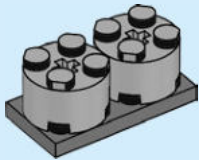

4

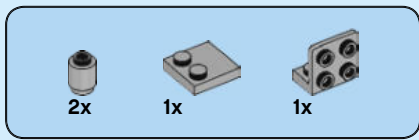
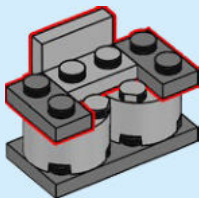

5

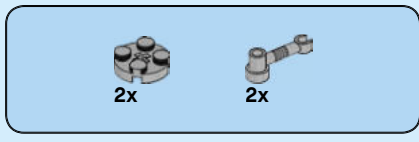
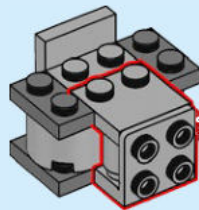
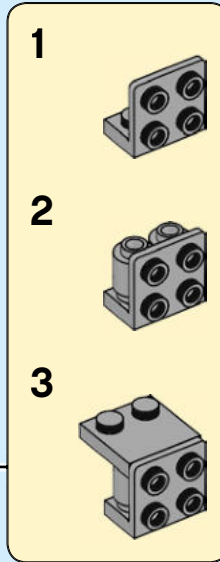

6

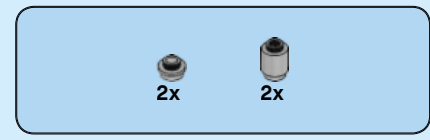
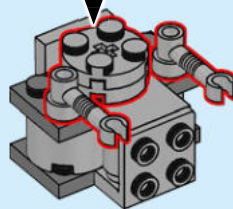
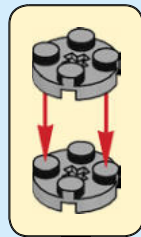

7

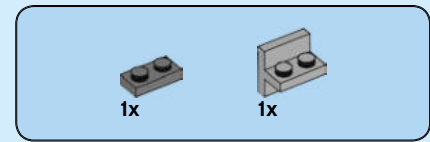
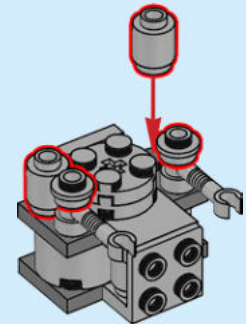

8

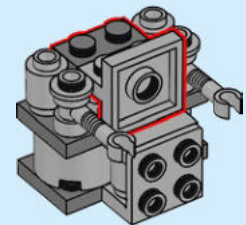



1x

9

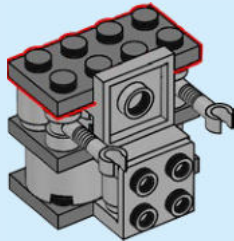

1x



1x

11

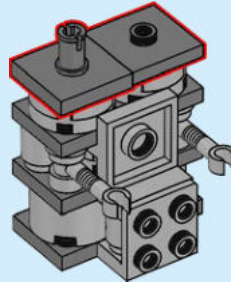

1x

13

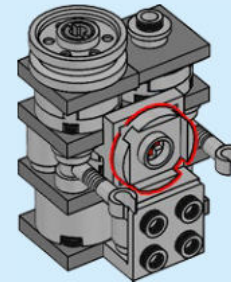

4x

10

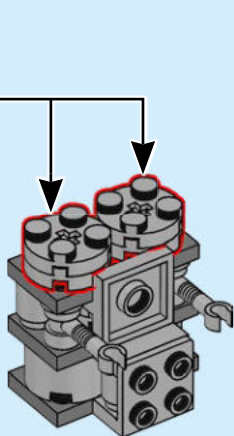

2x



1x



1x

12

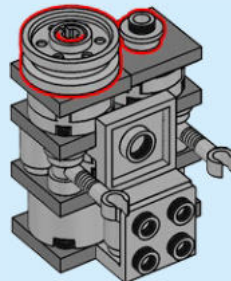

1x

14

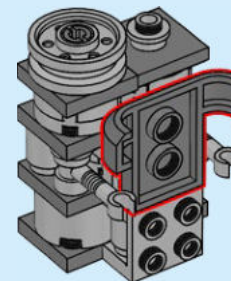

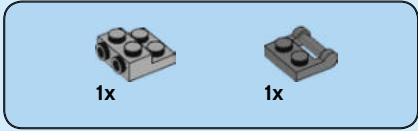

15

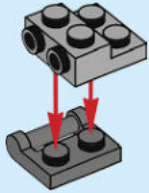

16

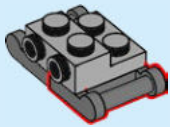

17

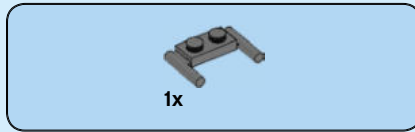
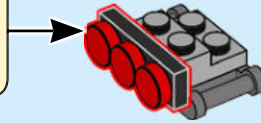
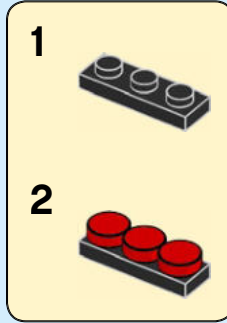

18

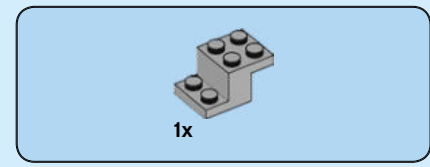
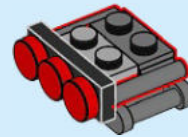

19

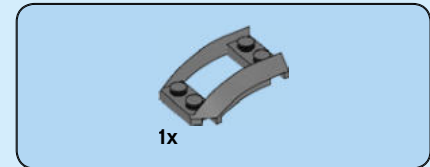
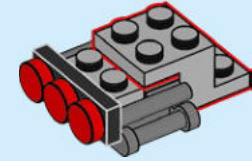

20





1x

21

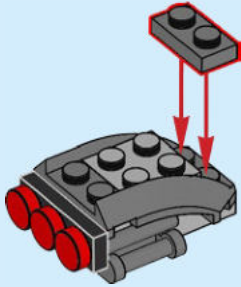

23

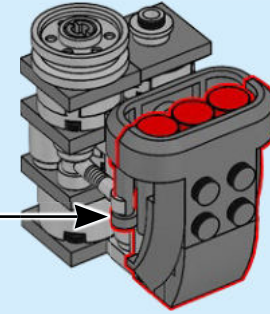

24

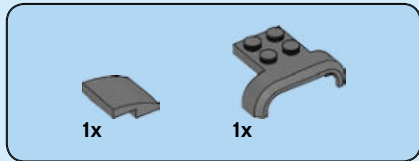
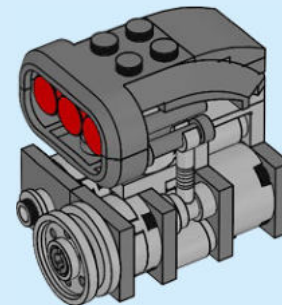
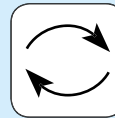

1x

1x

22



25

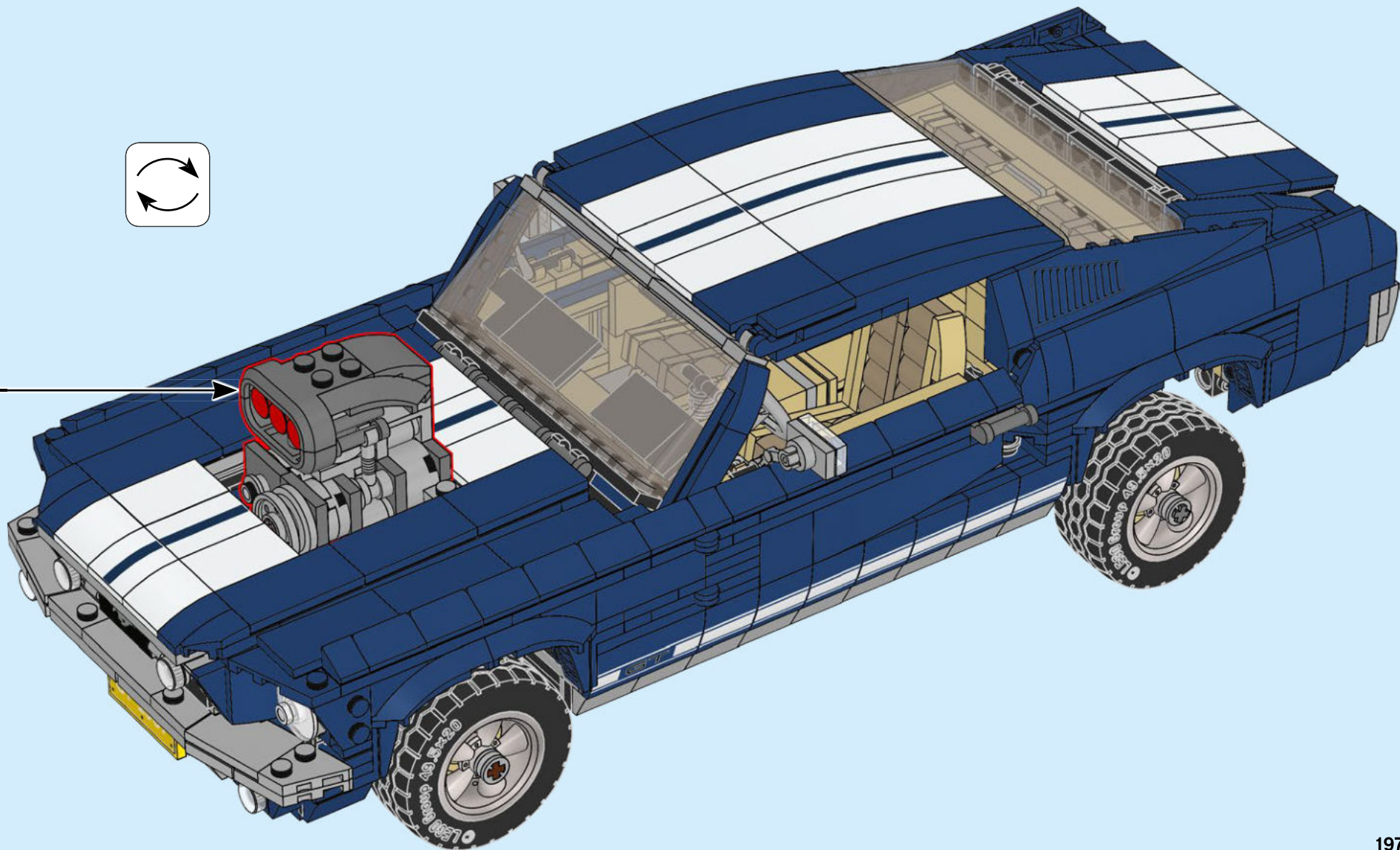
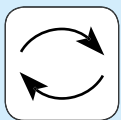

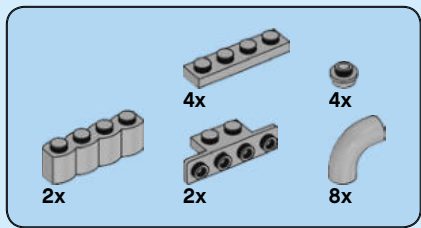

26

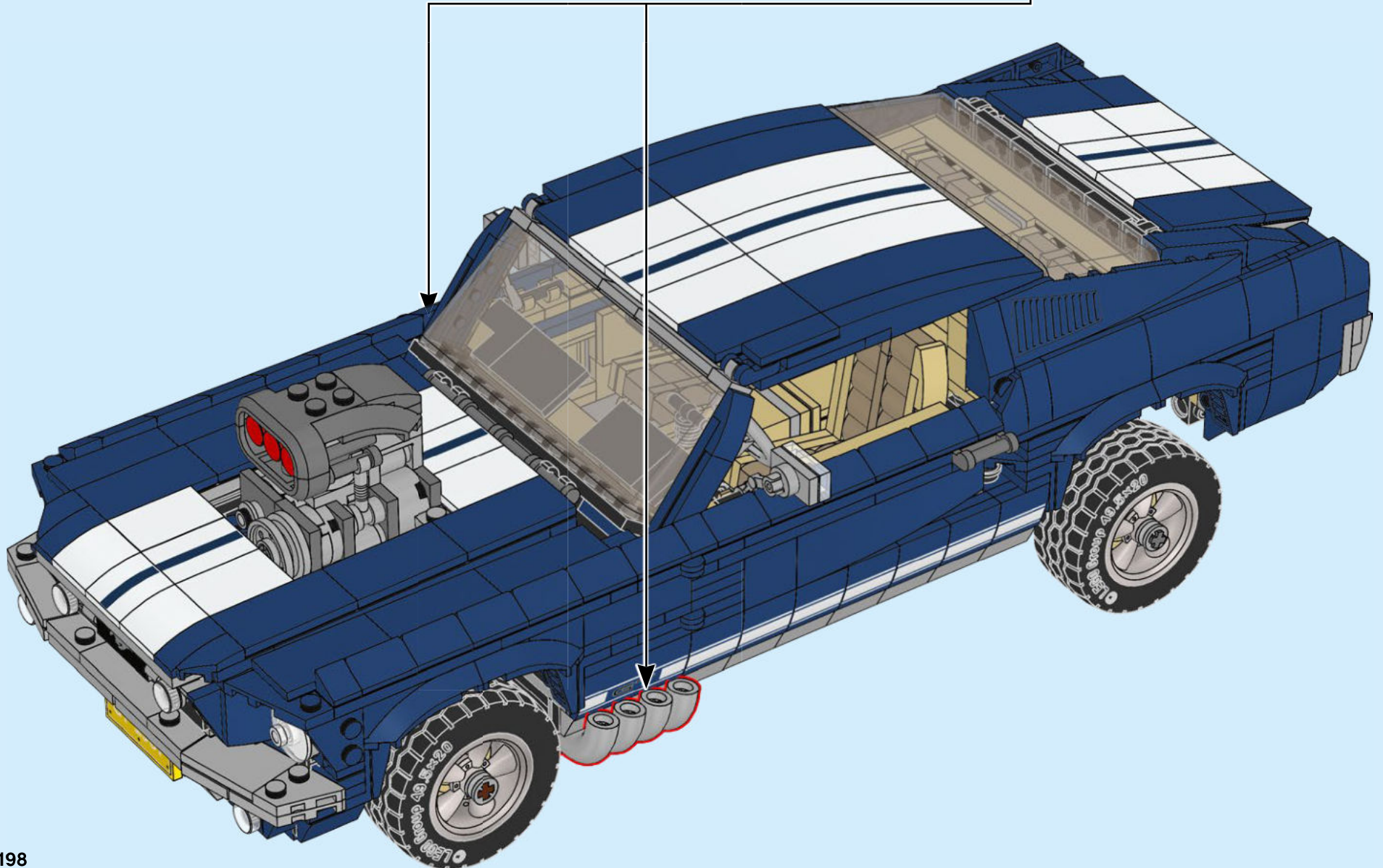
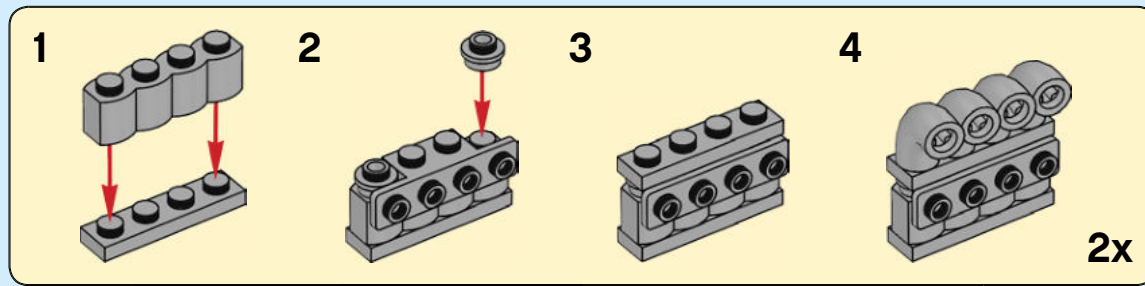

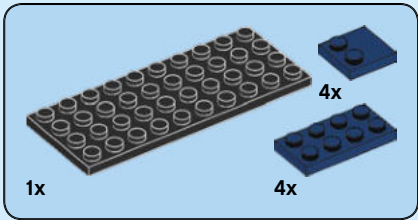
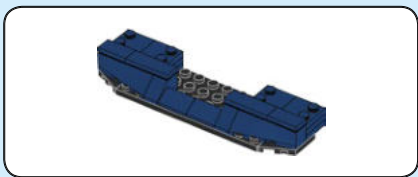

27

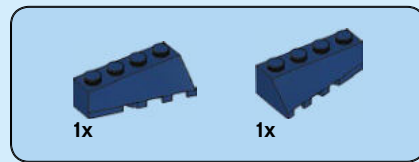
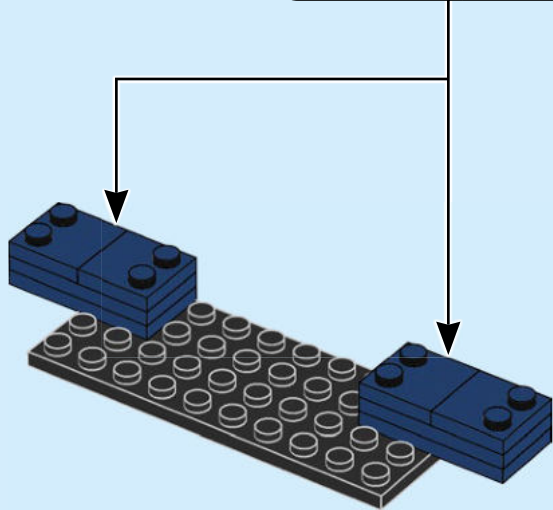
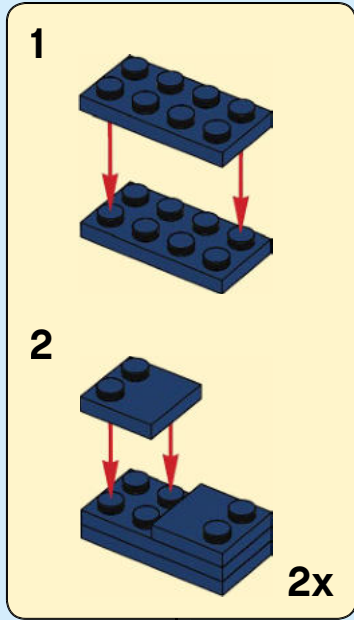

28

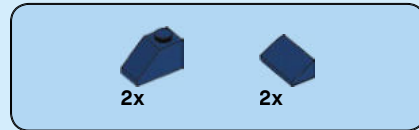
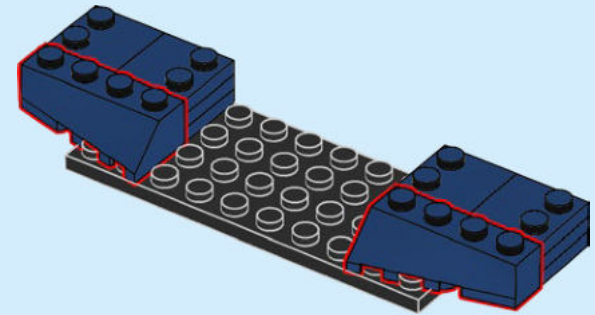

29

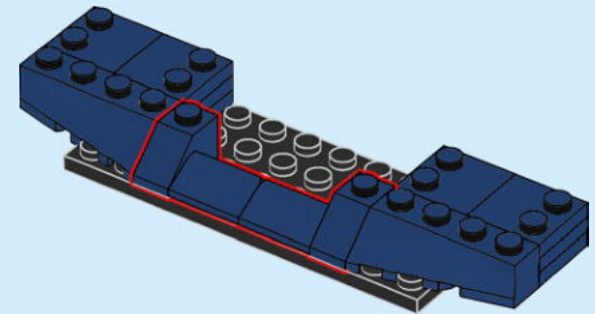

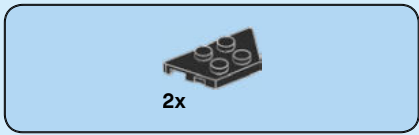

30

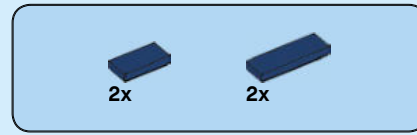
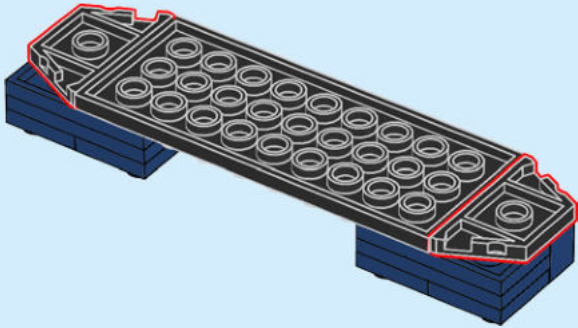
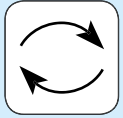

31

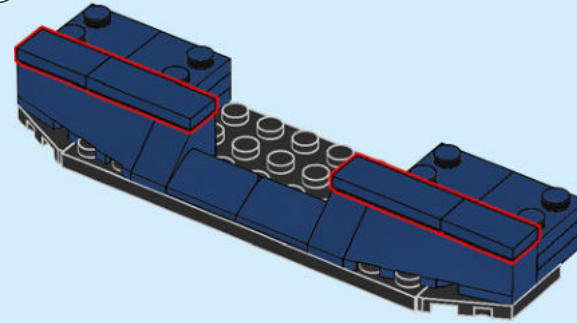
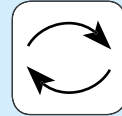

32

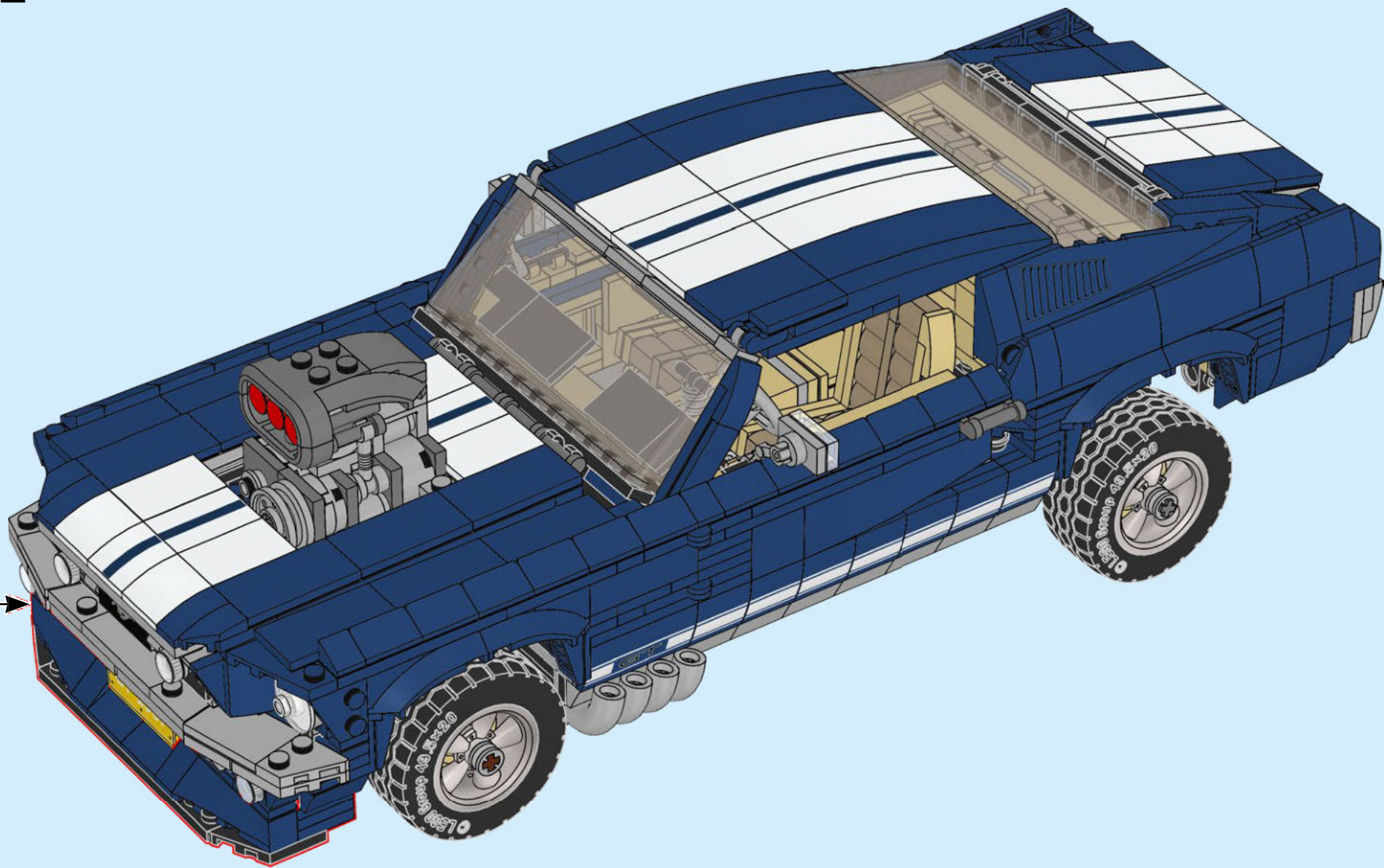

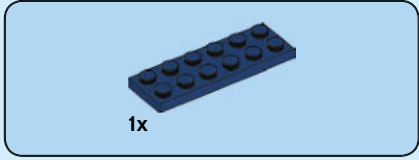
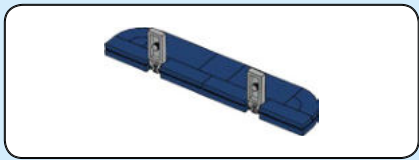

33

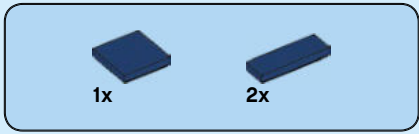

34

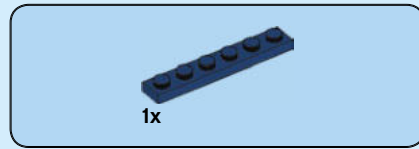
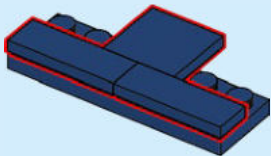

35

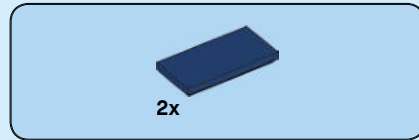
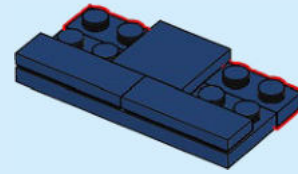

36

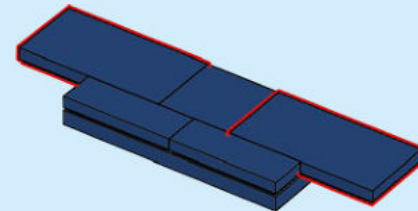

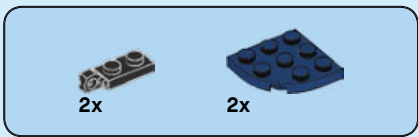

37

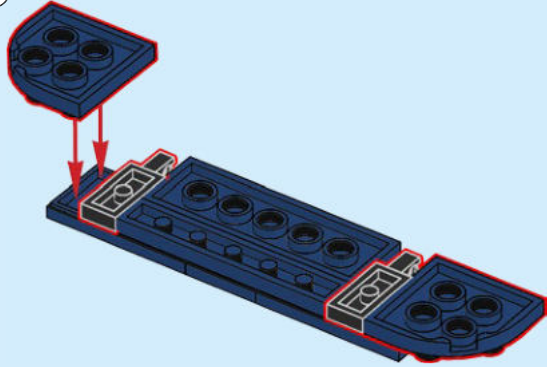
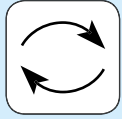

38

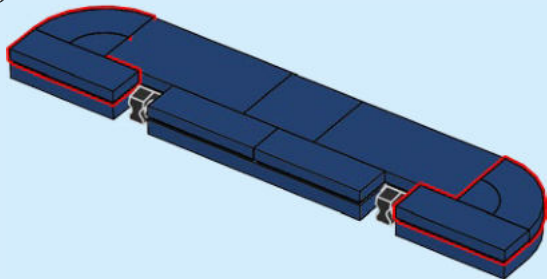
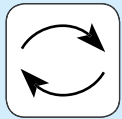

39

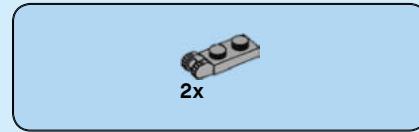
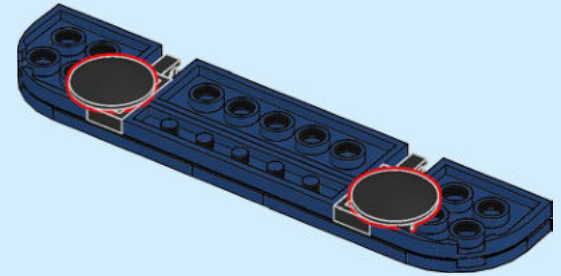
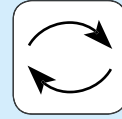

40

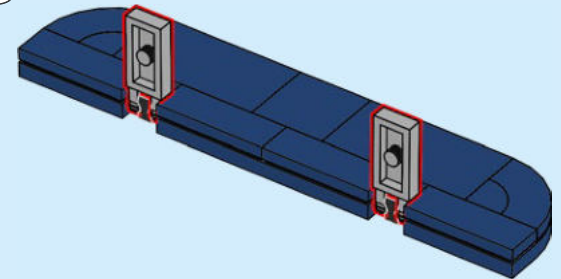
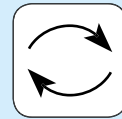

41

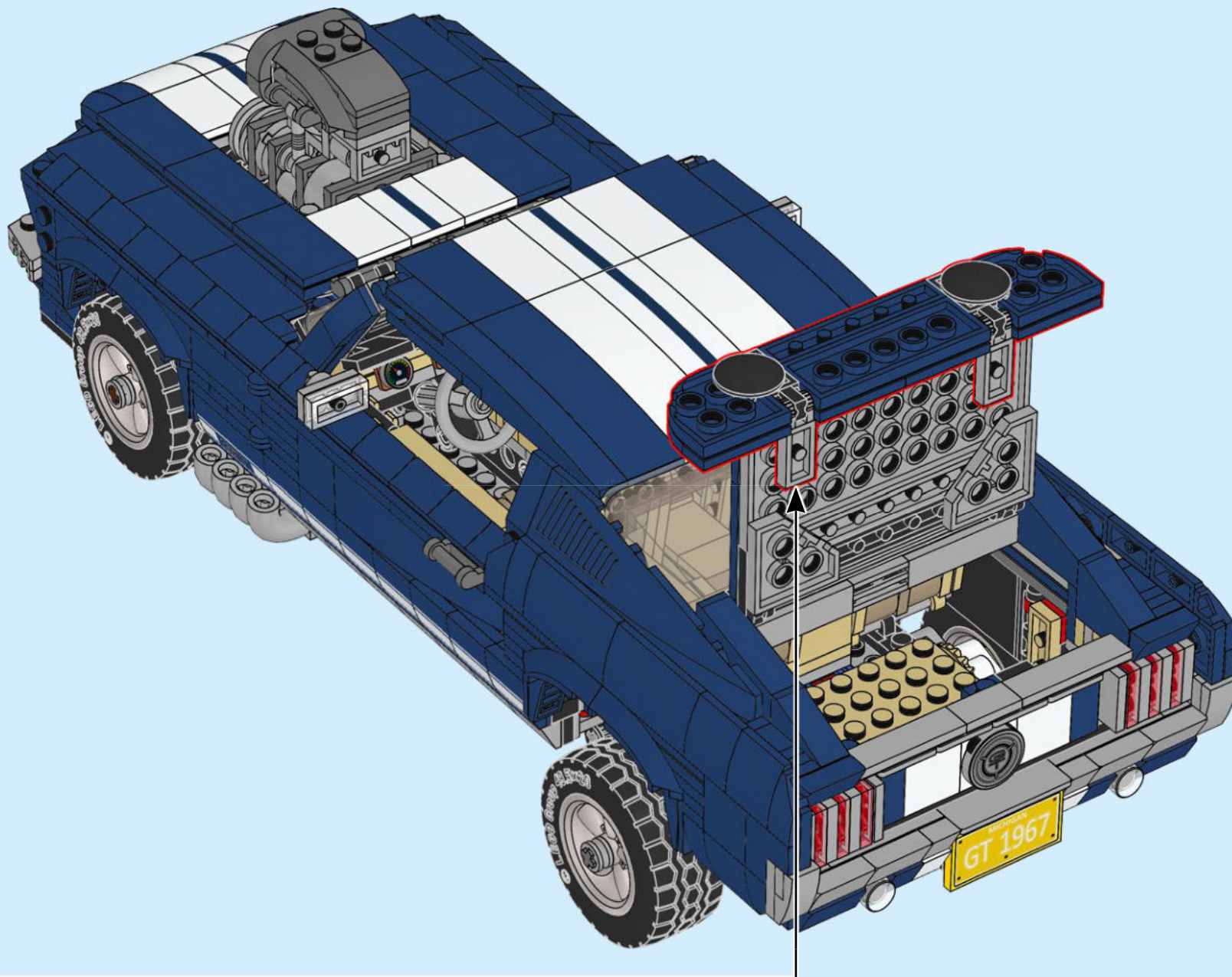

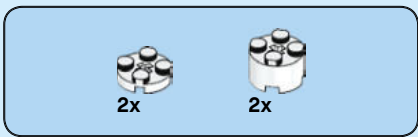

42

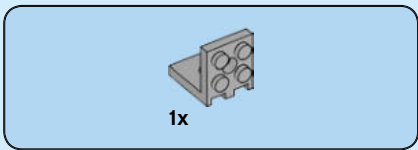
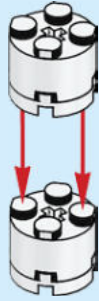

43

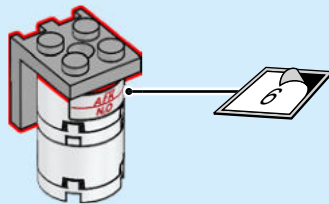

44

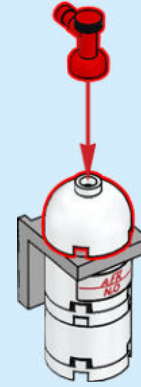

45

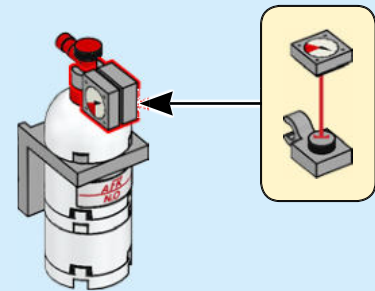

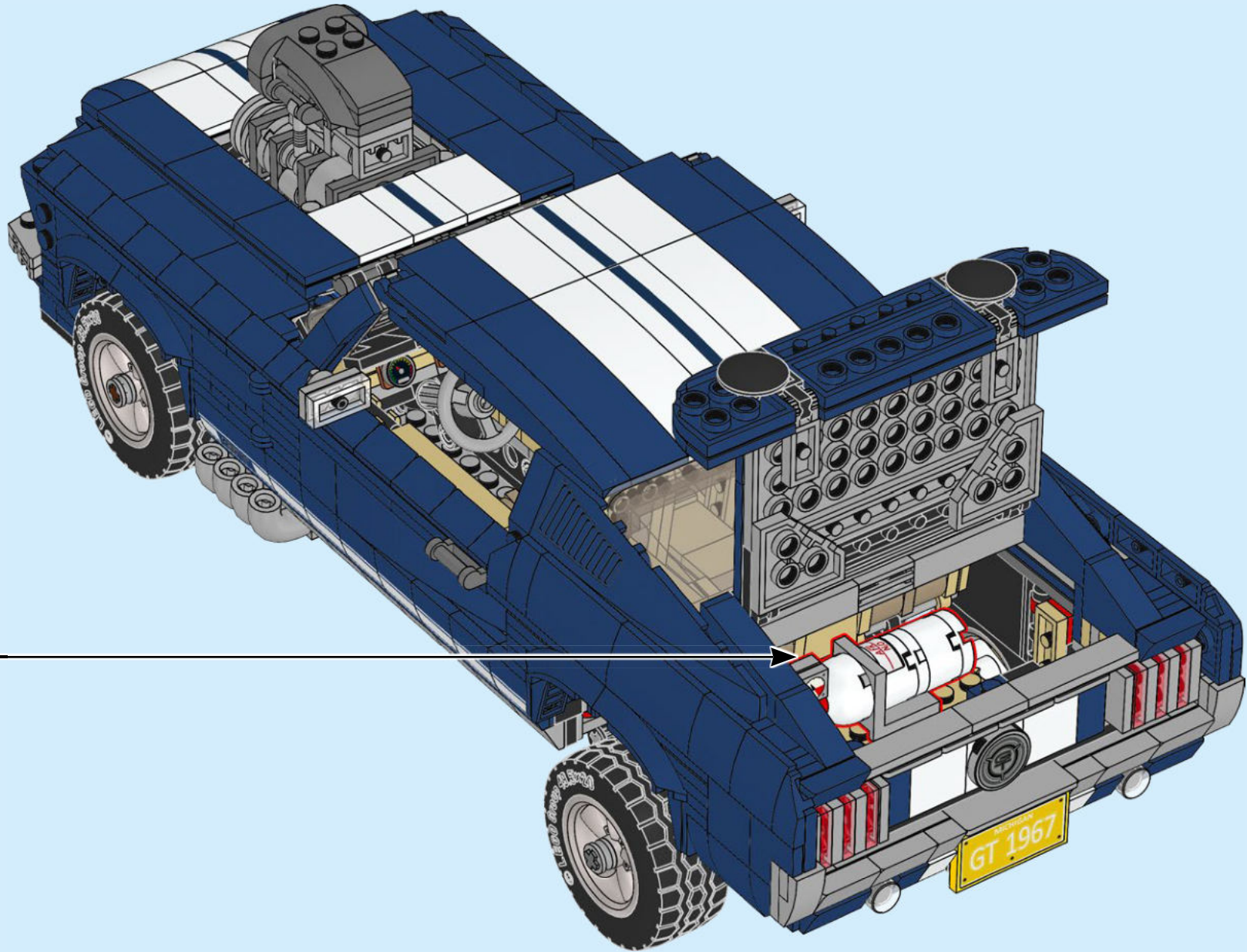



CREATOR™



LEGO.com/creatorexpert



EXPERT



10261



CREATOR™

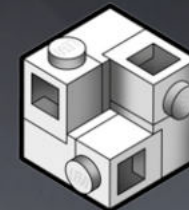

EXPERT

LICENCE TO BUILD



10262

007™ and James Bond materials © 1962-2018 Danjaq and MGM.
007™ and related James Bond Trademarks,™ Danjaq. All rights reserved.



ASTON MARTIN

007™

2x 4504369
 2x 4544140
 2x 403201
 1x 4216652
 2x 614301
 4x 6177268
 6x 3200001
 1x 6051511
 2x 6034044
 2x 6047220
 2x 6218822
 2x 306801
 2x 6258166
 1x 302201
 4x 242001
 4x 362301
 4x 6258380
 8x 6156667

7x 243101
 2x 6061047
 2x 6258071
 1x 302001
 2x 4560178
 2x 6253935
 1x 6258674
 6x 6252969
 2x 4179771
 4x 4516055
 6x 4159553
 2x 6057517
 4x 6232135
 8x 6029889
 2x 4666579
 2x 6232037

9x 4109995
 4x 6024495
 2x 6046922
 5x 4114026
 2x 6251252
 32x 4113917
 1x 4612873
 6x 6031962
 6x 6013081
 6x 6221467
 4x 4114084
 4x 6046924
 1x 4185177
 1x 4185177
 1x 6075179
 1x 613638
 8x 6132769
 8x 4121921

6x 4550324
 21x 4113233
 2x 6195544
 4x 6102772
 5x 6122047
 7x 4124067
 2x 4157277
 1x 4113988
 1x 4125217
 1x 6156462
 1x 6075179
 24x 614121
 3x 6063445
 1x 459921

3x 6130007
 1x 4153707
 7x 6271167
 1x 370124
 1x 243124
 2x 4560181
 2x 6130008
 2x 307021
 2x 4524644
 2x 4186678
 6x 4142865
 2x 4118897
 2x 6053011
 6x 6209519
 6x 4140806
 1x 6273211
 1x 6129995

9x 4206482
 6x 393723
 1x 6092582
 1x 306923
 2x 6179330
 2x 6212141
 2x 4195007
 4x 6194724
 6x 4514553
 2x 243123
 1x 4212411
 1x 4581501
 1x 300123
 1x 6171063
 4x 366623
 1x 389423

10x 614126
 1x 6073231
 2x 4560174
 4x 6066102
 2x 6187572
 6x 6234695
 2x 4184169
 1x 6104209
 1x 4143372
 7x 4278359
 1x 4109810
 2x 4548180
 1x 6024730
 1x 474026
 1x 6179182
 2x 4632571
 37x 4121715

1x 6195325
 2x 4107081
 5x 287726
 2x 4177444
 10x 4598528
 4x 4569733
 3x 4121966
 5x 6092585
 2x 6114987
 4x 6192309
 2x 6156991
 6x 6178922
 5x 6016172
 5x 4556158
 2x 6055630
 2x 6169990
 3x 4107761

2x 4288212
 2x 6093525
 2x 4183043
 4x 306826
 3x 6211476
 4x 4565323
 4x 6192346
 2x 6061032
 3x 300326
 2x 303926
 2x 6133722
 2x 6089119
 6x 235726
 5x 4551538
 2x 4121667
 2x 412822
 6x 362326

1x 6199908
 2x 4531412
 2x 6162892
 2x 300226
 2x 374726
 1x 4613153
 2x 6030286
 4x 302026
 2x 4629921
 1x 241926
 3x 379526
 2x 4653049
 4x 6055626
 2x 4495935

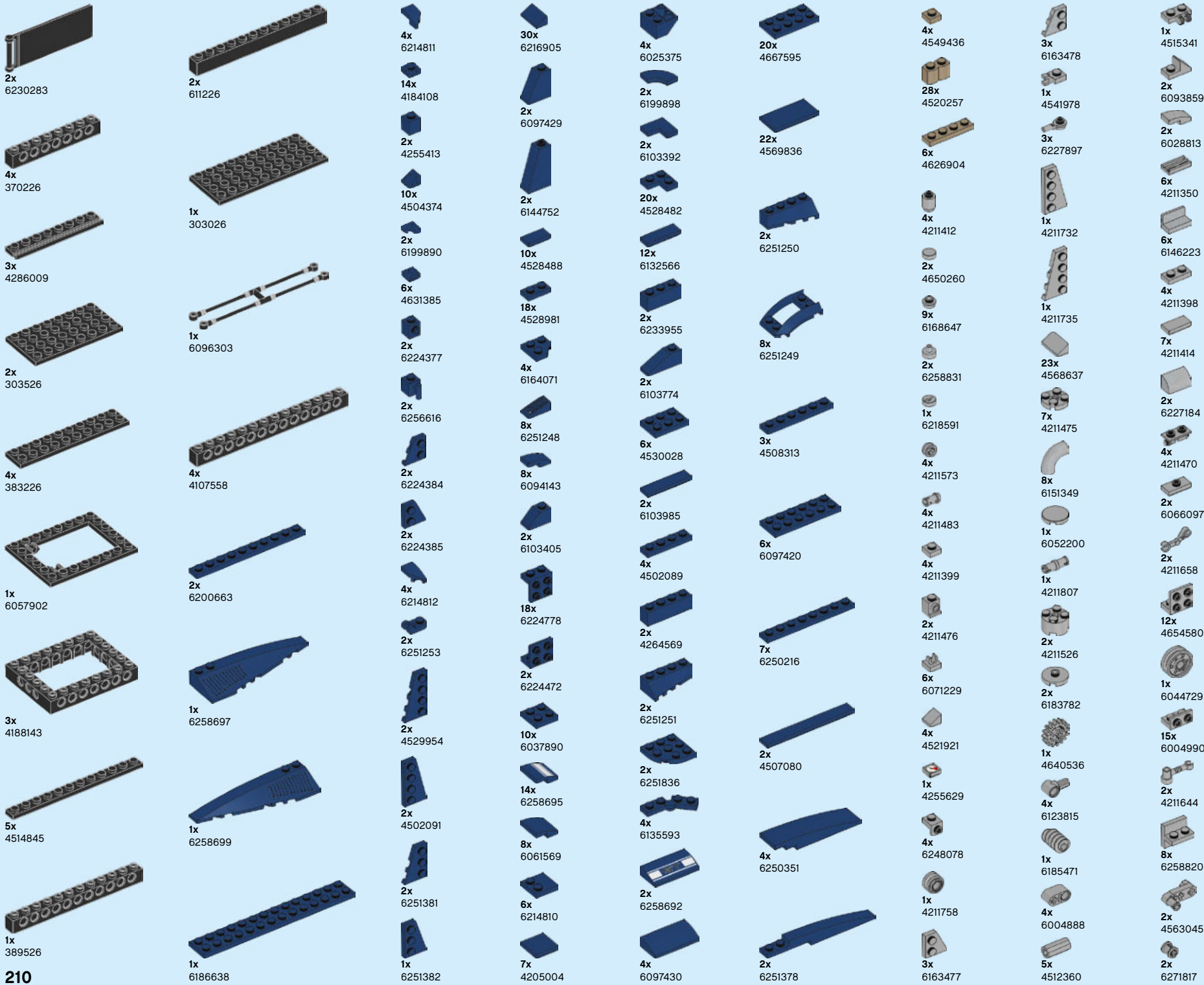

6x
4650498

2x
6245306

2x
6240204

6x
6240212

2x
6248949

1x
6022032

3x 3
6135494

1x
6240515

2x
6247783

4x
6245499

4x
6250349

2x
6030333

2x
4666449

10x
4211397

1x
6212077

6x
4211353

2x
4211804

4x
4654577

2x
4538007

1x
4525904

1x
4580510

2x
4211429

1x
6254807

1x
6258156

12x
6168615

4x
6116608

2x 5
4211639

4x
4507056

2x
6171894

1x
6093054

2x
4211833

1x
6071299

8x
4211356

3x
4211394

10x
4211445

2x
6015347

2x
4211361

8x
4503416

5x
4211395

1x
6195314

1x
6079461

5x
4211425

5x
4211481

2x 9
4535768

5x
4211406

2x
4211374

1x 11
4611705

2x
4211402

1x
4211360

4x
4211401

1x
6012451

2x
4211111

30x
4211063

2x
6055629

10x
6146321

3x
6126083

1x
4211129

1x
6071261

4x
6118832

1x
4263176

2x
4211024

2x 4
6083620

2x
6178912

2x
4211065

1x
4294289

3x 5.5
4508553

4x
6074651

2x
4211002

6x
4257526

Customer Service
Kundenservice
Service Consommateurs
Servicio Al Consumidor
LEGO.com/service or dial
: 00800 5346 5555
: 1-800-422-5346



WIN

GO TO WWW.LEGO.COM/PRODUCTFEEDBACK AND
GIVE US YOUR SHORT **FEEDBACK** ABOUT THIS
LEGO® SET FOR A CHANCE TO WIN
A COOL LEGO PRIZE.

Terms & Conditions apply

LEGO.com/productfeedback



GEWINNE

Erzähle uns auf
www.LEGO.com/productfeedback

etwas über die Erfahrungen, die
du mit diesem LEGO® Set gemacht
hast, und sichere dir die Chance
auf einen coolen LEGO Preis!

Es gelten die
Teilnahmebedingungen

GAGNE

Rends-toi sur
www.LEGO.com/productfeedback

et donne-nous quelques com-
mentaires sur ce produit LEGO®
pour avoir une chance de gagner
un prix LEGO !

Voir Conditions Générales

GANAN

Visita
www.LEGO.com/productfeedback

y envíanos tu opinión acerca de
este set LEGO®, ¡Participarás en el
sorteo de un premio LEGO!

Términos y Condiciones aplicables

获取奖品

登录
www.LEGO.com/productfeedback

给出关于此乐高®套装的简短反馈，
就有机会获得炫酷乐高奖品

《条款及条件》适用

경품 당첨 기회

www.LEGO.com/productfeedback

페이지로 이동하여 이 레고® 세트에
대한 간략한 피드백을 보내 주시고
멋진 레고 경품을 탈 수 있는 기회도
잡으십시오

약관 적용

ЗАПОЛНИ АНКЕТУ И ПОЛУЧИ ПРИЗ

Перейди по ссылке
www.LEGO.com/productfeedback

ответь всего на несколько во-
просов об этом наборе LEGO®,
и у тебя появится шанс выиграть
замечательный приз от компании
LEGO.

Применяются Условия и правила
участия